

TM 55-1905-220-14-3

TECHNICAL MANUAL

OPERATOR'S, ORGANIZATIONAL,
DIRECT SUPPORT, AND GENERAL SUPPORT
MAINTENANCE MANUAL

LANDING CRAFT UTILITY
LCU 1671-1679
(1905-01-009-1056)

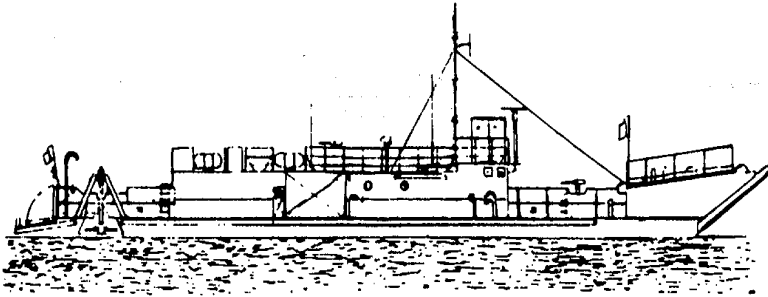

CHAPTER 3
OPERATOR MAINTENANCE
INSTRUCTIONS

TROUBLESHOOTING

HEADQUARTERS, DEPARTMENT OF THE ARMY

8 AUGUST 1983

CHANGE

NO. 2

HEADQUARTERS
DEPARTMENT OF THE ARMY
Washington, D.C., 31 December 1991

Operator's, Organizational,
Direct Support, and General Support
Maintenance Manual

LANDING CRAFT UTILITY
LCU 1671-1679
(1905-01-009-1056)

Approved for public release; distribution is unlimited

TM 55-1905-220-14-3, 8 August 1983, is changed as follows:

1. Remove and insert pages as indicated below. New or changed text material is indicated by a vertical bar in the margin. An illustration change is indicated by a miniature pointing hand.

| Remove pages | Insert pages |
|--------------------------------------|--------------------------------------|
| 3-39 and 3-40 3-223 through 3-226 | 3-39 and 3-40 3-223 through 3-226 |

2. Retain this sheet in front of manual for reference purposes.

By Order of the Secretary of the Army:

Official:

GORDON R. SULLIVAN
General, United States Army
Chief of Staff

MILTON H. HAMILTON
Administrative Assistant to the
Secretary of the Army
00425

DISTRIBUTION:

To be distributed in accordance with DA Form 12-25E, (qty rqr block no. 1060)

URGENT

**TM 55-1905-220-14-3
C1**

CHANGE



NO.1

HEADQUARTERS
DEPARTMENT OF THE ARMY
WASHINGTON, D.C., 27 June 1984

Operator's, Organizational,
Direct Support, and General Support
Maintenance Manual

LANDING CRAFT UTILITY
LCU 1671-1679
(1905-01-009-1056)

TM 55-1905-220-14-3, 8 August 1983, is changed as follows:

1. Remove and insert pages as indicated below. New or changed text material is indicated by a vertical bar in the margin. An illustration change is indicated by a miniature pointing hand.

Remove pages

Insert pages

c and d

2. Retain this sheet in front of manual for reference purposes.

By Order of the Secretary of the Army:

JOHN A. WICKHAM, JR.
General, United States Army
Chief of Staff

Official:

ROBERT M. JOYCE
Major General, United States Army
The Adjutant General

DISTRIBUTION:

To be distributed in accordance with DA Form 12-25D, Operator Maintenance Requirements for Marine Equipment, All.

URGENT

WARNING

DEATH

OR SEVERE INJURY MAY RESULT IF PERSONNEL FAIL TO OBSERVE THE GENERAL SAFETY PRECAUTIONS BELOW, AND THE SPECIFIC PRECAUTIONS CONTAINED IN THE TEXT.

- Wear safety glasses, safety shoes, and a hard hat to provide adequate protection.
- Death or severe injury may result if personnel fail to use a lifting device that is adequate for the item to be lifted.
- Ear protection must be worn when engines or machinery is in operation.
- Use care when using power tools.
- If cleaning agents are used, be sure area is adequately ventilated, and use protective gloves and goggles, or face shield and apron.
- Avoid excessive injection of ether into an engine during starting attempts. Follow the instructions on the container or by the manufacturer of the starting aid.
- Use the recommended air pressure when using compressed air to clean components. Too much air pressure can rupture or in some way damage a component and create a hazardous situation that can lead to personal injury.
- When working on an engine that is running, accidental contact with the hot exhaust manifold can cause severe burns.

WARNING (Cont)

- Use extreme care when near rotating fans, belts and pulleys.
- Avoid making contact across the terminals of the batteries and do not spill the contents of the battery.
- Keep clear of the Anchor Winch or Bow Ramp Winch while it is in operation.
- During any removal, disassembly, assembly, or installation of an electrical device, make sure all electrical power is disconnected, and tagged. (Circuit breaker in the OFF position and tagged).
- Improper functioning of Engine Exhaust System can cause injury or death.
- Personnel should know the location and operation of all equipment for emergency use.
- Before attempting to operate any equipment, read the instructions completely. Then, return to the appropriate section and follow the instructions.
- Do not enter a Winch Compartment alone.
- If the Halon System is activated (horn sounds), leave the compartment immediately. Check that no one is left, and then close and dog the hatch.
- Use extreme care when handling gasoline for the Salvage Pump.
- Store all flammable material in the Flammable Storage Compartment.

WARNING (CON'T)

- When cutting with a torch, or when welding, always station 'fire watches, ready with fire extinguishers,' in the vicinity on both sides of the plate that is being cut or welded.
- Prior to cutting or welding on the ramp, remove drain plugs on both sides of the ramp and check if ramp interior is primer coated. If primer coated, flush thoroughly with steam, carbon dioxide, or water. Do not reinstall drain plugs until the cutting and/or welding operation is completed. Failure to take this precaution may result in explosion of accumulated primer vapors.
- When refueling, shut down the electrical system. Observe the no smoking rule. Do not permit anyone to operate tools or equipment which may produce sparks near the refueling operation. Sparks or fire may ignite the diesel fuel and produce an explosion.
- Fuel oil and other petroleum products are highly volatile in extreme heat. To minimize the possibility of explosion, wipe up all spills at once, see that fuel lines and valves are not leaking and pump bilges regularly.
- Before attempting to remove any compressed air system lines or components, relieve air pressure from system. Failure to do so may result in injury or possible death to maintenance personnel.
- Before disconnecting a line in the hydraulic system, bleed the pressure from that portion of the line. Failure to do so may result in injury or possible death to maintenance personnel.
- When working inside the hydraulic oil supply tank, a portable-type circulating blower should be used to prevent vapor accumulation. For extended work periods inside the tank, an air line tube respirator should be worn. Station an observer outside tank in case worker is overcome by fumes.
- Acids can cause serious burns or blindness. Avoid contact with eyes, skin, or clothing. Do not breathe vapors. Wear rubber gloves, goggles, and a rubber apron when handling them. When diluting acids, do not add water to acid; the acid must be added to the mixture slowly and with constant mixing. In case of contact with acid, flush the affected area with plenty of water and obtain medical aid immediately.

WARNING (CON'T)

- Ramp hinge pins must be replaced one at a time, allowing three remaining pins to support ramp. Removal of two or more hinge pins may result in the weight of the ramp misaligning the remaining hinges, resulting in damage to ramp and possible injury or death to maintenance personnel.

TECHNICAL MANUAL
NO. 55-1905-220-14-3

HEADQUARTERS
DEPARTMENT OF THE ARMY
Washington, D.C., **8 August 1983**

OPERATOR'S, ORGANIZATIONAL,
DIRECT SUPPORT, AND GENERAL SUPPORT
MAINTENANCE MANUAL

LANDING CRAFT UTILITY
LCU 1671-1679
(1905-01-009-1056)

REPORTING ERRORS AND RECOMMENDING IMPROVEMENTS

You can help improve this manual. If you find any mistakes or if you know of a way to improve the procedures, please let us know. Mail your letter, DA Form 2028 (Recommended Changes to Publications and Blank Forms), or DA Form 2028-2 located in the back of this manual direct to: Commander, US Army Troop Support and Aviation Materiel Readiness Command, ATTN: DRSTS-MPSD, 4300 Goodfellow Blvd., St. Louis, MO 63120. A reply will be furnished directly to you.

TABLE OF CONTENTS

| | | PAGE |
|-------------|---|---------|
| CHAPTER 3 | OPERATOR MAINTENANCE INSTRUCTIONS | |
| Section I | Repair Parts, Special Tools, TMDE and Support Equipment | 3-1 |
| Section II | Service Upon Receipt | 3-1 |
| Section III | Lubrication | 3-4 |
| Section IV | Troubleshooting Symptom Index | 3-5 |
| INDEX | | Index-1 |

* This manual supersedes TM 55-1905-220-14-3, 31 July 1980.

LIST OF TABLES

| <u>TABLE NUMBER</u> | | <u>PAGE NUMBER</u> |
|-------------------------|---|------------------------|
| 3-1 | Propulsion Engine Exhaust Smoke Analysis Troubleshooting. | 3-16 |
| 3-2 | Propulsion Engine Hard Starting Troubleshooting. | 3-22 |
| 3-3 | Propulsion Engine Abnormal Engine Operation Troubleshooting. | 3-27 |
| 3-4 | Propulsion Engine No Fuel or Insufficient Fuel Troubleshooting. | 3-38 |
| 3-5 | Propulsion Engine High Lubricating Oil Consumption Troubleshooting. | 3-44 |
| 3-6 | Propulsion Engine Excessive Crankcase Pressure Troubleshooting. | 3-47 |
| 3-7 | Propulsion Engine Low Oil Pressure Troubleshooting. | 3-49 |
| 3-8 | Propulsion Engine Abnormal Engine Coolant Operating Temperature Troubleshooting. | 3-53 |
| 3-9 | Propulsion Engine Low or High Exhaust Valve Opening Pressure Troubleshooting. | 3-54 |
| 3-10 | Marine Gear Troubleshooting. | 3-56 |
| 3-11 | Hydrostarter Low or No Accumulator Pressure Troubleshooting. | 3-60 |
| 3-12 | Hydrostarter Cranking Speed Too Low Troubleshooting. | 3-65 |
| 3-13 | Hydrostarter Loss of Fluid From Reservoir Troubleshooting. | 3-66 |
| 3-14 | Hydrostarter Loss of Fluid Pressure When Engine Is Not Running Troubleshooting. | 3-66 |
| 3-15 | Hydrostarter Hand Pump Fails to Discharge Fluid Troubleshooting. | 3-68 |
| 3-16 | Hydrostarter Starter Turns But Engine Does Not Troubleshooting. | 3-70 |
| 3-17 | Hydrostarter Loss of Accumulator Precharge (Nitrogen) Troubleshooting. | 3-70 |
| 3-18 | Hydrostarter High Pressure in System (3500 psi or Above) Troubleshooting. | 3-72 |
| 3-19 | Hydrostarter Fluid Emerges from the Reservoir Filler Cap When Starter is Used Troubleshooting. | 3-73 |
| 3-20 | Hydrostarter Fluid Emerges Around Rubber Boot of Hand Pump Troubleshooting. | 3-73 |
| 3-21 | Hydrostarter Cranking Cycle Too Short Troubleshooting | 3-74 |
| 3-22 | Generator Engine Exhaust Smoke Analysis Trouble- shooting. | 3-75 |
| 3-23 | Generator Engine Hard Starting Troubleshooting. | 3-80 |
| 3-24 | Generator Engine Abnormal Engine Operation Troubleshooting. | 3-84 |
| 3-25 | Generator Engine No Fuel or Insufficient Fuel Troubleshooting. | 3-96 |
| 3-26 | Generator Engine High Lubricating Oil Consumption Troubleshooting. | 3-101 |

LIST OF TABLES (CONT)

| <u>TABLE NUMBER</u> | | <u>PAGE NUMBER</u> |
|-------------------------|---|------------------------|
| 3-27 | Generator Engine Excessive Crankcase Pressure Troubleshooting. | 3-102 |
| 3-28 | Generator Engine Low Oil Pressure Troubleshooting | 3-105 |
| 3-29 | Generator Engine Abnormal Engine Coolant Operating Temperature Troubleshooting. | 3-108 |
| 3-30 | Generator Engine Low or High Exhaust Valve Opening Pressure Troubleshooting. | 3-110 |
| 3-31 | Hydrostarter Low or No Accumulator Pressure Troubleshooting. | 3-112 |
| 3-32 | Hydrostarter Cranking Speed Too Low Troubleshooting | 3-115 |
| 3-33 | Hydrostarter Loss of Fluid From Reservoir Troubleshooting. | 3-116 |
| 3-34 | Hydrostarter Loss of Fluid Pressure When Engine Is Not Running Troubleshooting. | 3-117 |
| 3-35 | Hydrostarter Hand Pump Fails to Discharge Fluid Troubleshooting. | 3-118 |
| 3-36 | Hydrostarter Starter Turns But Engine Does Not Troubleshooting. | 3-120 |
| 3-37 | Hydrostarter Loss of Accumulator Precharge (Nitrogen) Troubleshooting. | 3-120 |
| 3-38 | Hydrostarter High Pressure in System (3500 psi or Above) Troubleshooting. | 3-122 |
| 3-39 | Hydrostarter Fluid Emerges' From the Reservoir Filler Cap When Starter Is Used Troubleshooting. | 3-122 |
| 3-40 | Hydrostarter Fluid Emerges Aaround Rubber Boot of Hand Pump Troubleshooting. | 3-123 |
| 3-41 | Hydrostarter Cranking Cycle Too Short Troubleshooting. | 3-123 |
| 3-42 | Generator Troubleshooting. | 3-125 |
| 3-43 | Switchboard Troubleshooting. | 3-127 |
| 3-44 | 24VDC Rectifier Troubleshooting. | 3-133 |
| 3-45 | Bow Ramp Winch Troubleshooting. | 3-135 |
| 3-46 | Bow Ramp Winch Brake Troubleshooting. | 3-138 |
| 3-47 | Bow Ramp Winch Motor Troubleshooting. | 3-140 |
| 3-48 | Anchor Winch Winch Troubleshooting. | 3-143 |
| 3-49 | Anchor Winch Slack Puller Troubleshooting. | 3-146 |
| 3-50 | Anchor Winch Disconnect Clutch Troubleshooting. | 3-148 |
| 3-51 | Anchor Winch Torque Converter Troubleshooting. | 3-149 |
| 3-52 | Anchor Winch Hydraulic Tank Balanced Piston Relief Valves Troubleshooting. | 3-158 |
| 3-53 | Anchor Winch Hydraulic Tank Check Valves Troubleshooting. | 3-160 |
| 3-54 | Anchor Winch Hydraulic Tank Pressure Control Valves Troubleshooting. | 3-161 |
| 3-55 | Anchor Winch Hydraulic Tank Pressure Reducing Valves Troubleshooting. | 3-162 |

LIST OF TABLES (CONT)

| <u>TABLE NUMBER</u> | | <u>PAGE NUMBER</u> |
|-------------------------|--|------------------------|
| 3-56 | Anchor Winch Hydraulic Tank Directional Control Valve Troubleshooting. | 3-164 |
| 3-57 | Anchor Winch Hydraulic Tank Troubleshooting. | 3-165 |
| 3-58 | Anchor Winch Hydraulic Pump Troubleshooting. | 3-167 |
| 3-59 | Anchor Winch Engine Exhaust Smoke-Analysis Troubleshooting. | 3-168 |
| 3-60 | Anchor Winch Engine Hard Starting Troubleshooting. | 3-174 |
| 3-61 | Anchor Winch Engine Abnormal Engine Operation Troubleshooting. | 3-178 |
| 3-62 | Anchor Winch Engine No Fuel or Insufficient Fuel Troubleshooting. | 3-189 |
| 3-63 | Anchor Winch Engine High Lubricating Oil Consumption Troubleshooting. | 3-194 |
| 3-64 | Anchor Winch Engine Excessive Crankcase Pressure Troubleshooting. | 3-196 |
| 3-65 | Anchor Winch Engine Low Oil Pressure Troubleshooting | 3-199 |
| 3-66 | Anchor Winch Engine Abnormal Engine Coolant Operating Temperature Troubleshooting. | 3-203 |
| 3-67 | Anchor Winch Engine Low or High Exhaust Valve Opening Pressure Troubleshooting. | 3-205 |
| 3-68 | Anchor Winch Engine Low or No Accumulator Pressure Troubleshooting. | 3-206 |
| 3-69 | Anchor Winch Engine Hydrostarter Cranking Speed Too Low Troubleshooting. | 3-210 |
| 3-70 | Anchor Winch Engine Hydrostarter Loss of Fluid From Reservoir Troubleshooting. | 3-211 |
| 3-71 | Anchor Winch Engine Hydrostarter Loss of Fluid Pressure When Engine Is Not Running Troubleshooting. | 3-211 |
| 3-72 | Anchor Winch Engine Hydrostarter Hand Pump Fails To Discharge Fluid Troubleshooting. | 3-213 |
| 3-73 | Anchor Winch Engine Hydrostarter Starter Turns But Engine Does Not Troubleshooting. | 3-215 |
| 3-74 | Anchor Winch Engine Hydrostarter Loss of Accumulator Precharge (Nitrogen) Troubleshooting. | 3-215 |
| 3-75 | Anchor Winch Engine Hydrostarter High Pressure In System (3500 psi or Above) Troubleshooting. | 3-217 |
| 3-76 | Anchor Winch Engine Hydrostarter Fluid Emerges From the Reservoir Filler Cap When Starter Is Used Troubleshooting. | 3-217 |
| 3-77 | Anchor Winch Engine Hydrostarter Fluid Emerges Around Rubber Boot of Hand Pump Troubleshooting. | 3-218 |
| 3-78 | Hydrostarter Cranking Cycle Too Short Troubleshooting | 3-218 |
| 3-79 | Centralized Hydraulic System Hydraulic Power Unit Troubleshooting. | 3-219 |
| 3-80 | Centralized Hydraulic System Controller Troubleshooting. | 3-222 |

LIST OF TABLES (CONT)

| <u>TABLE NUMBER</u> | | <u>PAGE NUMBER</u> |
|-------------------------|---|------------------------|
| 3-81 | Stern Gate Hydraulic System Troubleshooting. | 3-224 |
| 3-82 | Mast Hydraulic System Troubleshooting. | 3-225 |
| 3-83 | "A" Frame Hydraulic Winch Troubleshooting. | 3-228 |
| 3-84 | Steering Controller Troubleshooting. | 3-231 |
| 3-85 | Steering Cub Hydraulic Pump Troubleshooting. | 3-233 |
| 3-86 | Steering System Hydraulic Directional Control Valve Troubleshooting. | 3-236 |
| 3-87 | Hydraulic Steering Cylinder and Adjustable Links Troubleshooting. | 3-237 |
| 3-88 | Rudder Angle Indicator and Repeatback Transmitter Troubleshooting. | 3-238 |
| 3-89 | Heading Selector Troubleshooting. | 3-239 |
| 3-90 | Steering Control Panel Troubleshooting. | 3-240 |
| 3-91 | Remote Magnetic Heading System Troubleshooting. | 3-242 |
| 3-92 | Ship's Course Indicator Troubleshooting. | 3-244 |

CHAPTER 3
OPERATOR MAINTENANCE INSTRUCTIONS

OVERVIEW.

The operator maintenance instructions in this chapter apply to the following:

| <u>DESCRIPTION</u> | <u>PARAGRAPH</u> |
|---------------------------------|------------------|
| Propulsion System | 3-6 |
| Electric Power and Distribution | 3-58 |
| Bow Ramp and Winch | 3-115 |
| Stern Gate3-123 | |
| Anchor/Handling System | 3-127 |
| Central Hydraulic System | 3-183 |
| Steering System | 3-200 |

Chapter 4 contains the maintenance instructions for all auxiliary equipment.

**SECTION I. REPAIR PARTS, SPECIAL TOOLS, TMDE,
AND SUPPORT EQUIPMENT**

3-1. GENERAL REPAIR PARTS, SPECIAL TOOLS, TMDE, AND SUPPORT EQUIPMENT.

Repair parts, special tools, test, maintenance, diagnostic equipment, (TMDE),and support equipment are listed and illustrated in TM55-1905-220-20P. All fabricated tools are listed in Appendix H.

SECTION II. SERVICE UPON RECEIPT

3-2. PRELIMINARY SERVICING OF EQUIPMENT.

a. General. When a landing craft is received, inspect all items for damage that may have occurred during shipping or setting-up operations. Particular attention should be directed toward loose or missing nuts, bolts, screws, drainplugs, draincocks, oil plugs, assemblies, subassemblies, or components that may be easily lost or broken in transit. All other onboard equipment listed in basic issue items list, or packing lists, on new or used equipment should be similarly inspected and all discrepancies carefully noted.

b. Batteries. Batteries may be shipped separately, or installed for convenience with the electrolyte shipped separately.

- (1) If batteries are not installed, uncrate and install.
- (2) If batteries are installed, remove filler caps and carefully fill each cell with electrolyte until level is 3/8 inch (9.53 mm) above plates. Replace filler caps.

WARNING

Handle electrolyte with care. It is capable of inflicting severe burns. Solution contacting body must be washed off with fresh water immediately. Do not smoke or use open flame while servicing batteries. Batteries generate a hydrogen gas which is highly explosive.

- (3) For testing of batteries, refer to PMCS Table 2-4.

c. Inspection. The following areas will be carefully inspected for proper component attachment, or damaged components.

- (1) Marine Drive. In the forward and aft engine rooms:

- (a) Check all tube and hose connections for tightness.
- (b) Inspect for proper connection of marine shaft to propeller shaft.
- (c) Inspect for evidence of oil leakage in marine gear.
- (d) Inspect for loose components, broken castings and bolt tightness.
- (e) Check that shaft seal tank is full of clean water.
- (f) Inspect for cracked, dented, or broken parts.

(2) Propulsion Engine. Inspect propulsion engine for loose or broken components. Pay particular attention to heat exchanger and engine. Check air cleaner and emergency stop lever. Check engine and transmission controls for proper connection and adjustment.

- (a) Check engine and transmission oil level and level of coolant in heat exchanger.
- (b) Inspect floor and bilge area around engine for oil drippings that may indicate a leaky seal, or loose oil or fuel drainplug.
- (c) Inspect exhaust system connections and ensure that end tube and end cap is free to operate.
- (d) Check all hoses for cracks or leaks.
- (e) Check tension for all drive belts.
- (f) Check accumulator oil reservoir for the proper amount of oil.

(3) Central Hydraulic System, Lines and Fittings.

- (a) Inspect all areas of hydraulic system for evidence of oil leakage including the following: Main mast, anchor winch, "A" frame and stern gate.
- (b) Check that hydraulic reservoir is filled to proper level.

(4) Steering. Check that all steering arms, rods, hydraulic cylinders, hydraulic cub pump, and connections are secure and in good condition.

(5) Tanks, Ballast, Fresh Water, Fuel Oil, and Lubricating Oil.

- (a) Check manholes for signs of leakage.
- (b) Check all piping for damage.
- (c) Check all valves for leakage.

(6) Miscellaneous. Visually inspect and check the following items:

- (a) Ensure that all bilge pump inlet screens are free of debris.
- (b) Inspect all exposed electrical terminals for security of attachment and freedom from corrosion.
- (c) Check that all shut off valves are closed.
- (d) Check that all strainers in the sea chests are free of debris.
- (e) Inspect generator switch panel for loose or broken wires or damaged components. Make sure all switches are in the shore power position.
- (f) Check all wye strainers in the fire stations.
- (g) Inspect basic issue items for presence of all items listed, and for serviceability.

d. Servicing and Equipment. When a landing craft is received, perform all preventive maintenance checks and services. Before filling fuel tanks, cooling system, hydraulic reservoir, engine crankcase, transmission oil reservoir, or oil reservoir of any component, ensure that associated draincocks are closed, and all barrier material has been removed.

(1) Filters. Hydraulic filters are susceptible to easy contamination on new equipment. Check frequently and change elements after first 50 hours of operation.

(2) Hydraulic Reservoir. The central hydraulic oil reservoir must be filled to the level indicated on the sight gage. When all systems have been actuated, the level must be rechecked under the following conditions: Raised mast, lower anchor, and lower stern gate.

CAUTION

Maintain proper oil level at all times to prevent damage to various hydraulic components and to assure proper unit component operation.

(3) Engine. Check engine oil level. Refer to lubrication order for type oil to add when dipstick indicates level is low. Check gasket in oil filler cap for damage or deterioration. Check engine oil filters for oil leaks. Drain a small amount of oil from filters to check condition. Drain, replace filter element, and refill when dirty. Check and ensure that belt tension of all accessory drives are properly adjusted. Inspect and clean air cleaner filter element if necessary. Check hose for breaks, cracks, and proper clamp fastening.

(4) Heat Exchanger. Check heat exchanger hose for cracks, breaks, or leaks and clamps for tightness. Add coolant when necessary.

(5) Fuel System. Moisture accumulates in fuel tanks and filters from condensation. Drain filters. Drain at least one pint of fuel from each tank, or until all water has been drained from system. Fill fuel tanks. Check fuel lines, connections and tank vents for leaks. Place crossover line valves in open position.

(6) Marine Gear. Check and fill transmission with oil in accordance with current lubrication order. Ensure that drive shafts, and controls are mounted securely. Check all hoses and tubing connections for tightness.

3-3. INSTALLATION OF SEPARATELY PACKED COMPONENTS.

Normally, there are no components packed separately. Loose items of equipment subject to loss, damage, or pilferage, may be boxed and secured on the landing craft. Such items should be unpacked and properly stowed during inspection and servicing of equipment on receipt.

SECTION III. LUBRICATION

3-4. GENERAL LUBRICATION.

Refer to Lubrication Order LO-55-1905-220 for lubrication instructions.

SECTION IV. TROUBLESHOOTING SYMPTOM INDEX

3-5. GENERAL TROUBLESHOOTING SYMPTOM INDEX.

a. This table lists the common malfunctions which you may find during the operation and maintenance of the following components:

- Anchor Handling
- Bow Ramp and Winch
- Centralized Hydraulic System
- Electric Power and Distribution
- Propulsion System
- Stern Gate
- Steering System

b. You should perform the tests/inspections and corrective actions in the order listed.

c. This manual cannot list all malfunctions that may occur, nor all tests or inspections and corrective actions. If a malfunction is not listed or is not corrected by listed corrective actions, notify your supervisor.

d. Refer to Chapter 4 for the maintenance procedures for auxiliary machinery.

SYMPTOM INDEX

NOTE

M in table number indicates Malfunction item number.

| EQUIPMENT | MALFUNCTION | TABLE |
|---------------------------|--|---------|
| "A" FRAME HYDRAULIC WINCH | | 3-83 |
| | Motor runs but drum does not turn | 3-83-M3 |
| | Inoperative | 3-83-M1 |
| | Sluggish operation | 3-83-M2 |
| ANCHOR WINCH | Disconnect Clutch | |
| | Clutch binding | 3-50-M2 |
| | Clutch slipping | 3-50-M1 |
| Hydraulic Pump | | 3-58 |
| | Lack of pressure | 3-58-M2 |
| | Loss of fluid from pump | 3-58-M1 |
| Hydraulic Tank | Balanced Piston Relief Valves | 3-52 |
| | Erratic pressure | 3-52-M1 |
| | Excessive noise or chatter | 3-52-M3 |
| | Low pressure or no pressure | 3-52-M2 |
| Check Valves | | 3-53 |
| | Erratic pressure | 3-53-M1 |
| | Excessive noise or chatter | 3-53-M2 |
| Directional Control Valve | | 3-56 |
| | Erratic pressure | 3-56-M1 |
| | Excessive noise or chatter | 3-56-M3 |
| | Low pressure or no pressure | 3-56-M2 |
| Hydraulic Tank | | 3-57 |
| | Loss of fluid from hydraulic tank assembly | 3-57-M1 |
| | Poor performance | 3-57-M2 |
| Pressure Control Valves | | 3-54 |
| | Erratic Pressure | 3-54-M1 |
| | Excessive noise or chatter | 3-54-M3 |
| | Low pressure or no pressure | 3-54-M2 |
| Pressure Reducing Valves | | 3-55 |
| | Erratic pressure | 3-55-M1 |
| | Excessive noise or chatter | 3-55-M2 |

| EQUIPMENT | MALFUNCTION | TABLE |
|------------------------------|---|---------|
| Slack Puller | Inoperative | 3-49 |
| | Leaking grease or oil | 3-49-M3 |
| | Noise | 3-49-M2 |
| Torque Converter | | 3-49-M1 |
| | Excessive pressure | 3-51 |
| | Loss of fluid from converter | 3-51-M4 |
| | Low output horsepower | 3-51-M1 |
| Winch | Poor performance and overheating of converter | 3-51-M3 |
| | | 3-51-M2 |
| | Drive brake-slipping | 3-48 |
| | Drive gear | 3-48-M2 |
| | Level wind assembly-noise | 3-48-M3 |
| ANCHOR WINCH ENGINE | Universal joint assembly-noise | 3-48-M4 |
| | | 3-48-M1 |
| | Abnormal Engine Coolant Operating Temperature | 3-66 |
| | Above normal | 3-66-M1 |
| Abnormal Engine Operation | Below normal | 3-66-M2 |
| | Detonation | 3-61 |
| | Lack of power | 3-61-M3 |
| Excessive Crankcase Pressure | Uneven running or frequent stalling | 3-61-M2 |
| | | 3-61-M1 |
| | Air from blower or air box | 3-64 |
| | Breather restriction | 3-64-M3 |
| | Cylinder blow-by | 3-64-M2 |
| Exhaust Smoke Analysis | Excessive exhaust back pressure | 3-64-M1 |
| | | 3-64-M4 |
| | Black or gray smoke | 3-59 |
| | Blue smoke | 3-59-M1 |
| Hard Starting | White smoke | 3-59-M2 |
| | | 3-59-M3 |
| | Engine will not rotate | 3-60 |
| | Inoperative starting aid at low ambient temperature | 3-60-M1 |
| | Low compression | 3-60-M5 |
| | Low cranking speed | 3-60-M4 |
| No fuel | 3-60-M2 | |
| | 3-60-M3 | |

| EQUIPMENT | MALFUNCTION | TABLE |
|-----------|---|---------|
| | High Lubricating Oil Consumption | 3-63 |
| | External leaks | 3-63-M1 |
| | Internal leaks | 3-63-M2 |
| | Oil control at cylinder | 3-64-M3 |
| | Hydrostarter | |
| | Cranking Speed Too Low | 3-69 |
| | Fluid Emerges Around Rubber Boot of Hand Pump | 3-77 |
| | Fluid Emerges from the Reservoir Filler Cap When | |
| | Starter Is Used | 3-76 |
| | Hand Pump Fails to Discharge Fluid | 3-72 |
| | High Pressure in System (3500 Psi or above (24,133 kPa) | 3-75 |
| | Loss of Accumulator Precharge (Nitrogen) | 3-75 |
| | Loss of Fluid Pressure when Engine is not Running | 3-71 |
| | Loss of Fluid from Reservoir | 3-70 |
| | Starter Turns but Engine Does Not | 3-73 |
| | Low or High Exhaust Valve Opening Pressure | 3-67 |
| | High valve opening pressure | 3-67-M2 |
| | Low exhaust valve opening pressure | 3-67-M1 |
| | Low or No Accumulator Pressure | 3-68 |
| | Engine driven pump fails to raise pressure | 3-68-M1 |
| | Low Oil Pressure | 3-65 |
| | Lubricating oil | 3-65-M1 |
| | Oil pump | 3-65-M4 |
| | Poor circulation | 3-65-M2 |
| | Pressure gage | 3-65-M3 |
| | No Fuel or Insufficient Fuel | 3-62 |
| | Air leaks | 3-62-M1 |
| | Faulty fuel pump | 3-62-M3 |
| | Faulty installation | 3-62-M4 |
| | Flow obstruction | 3-62-M2 |

| EQUIPMENT | MALFUNCTION | TABLE |
|---|--|---------|
| BOW RAMP WINCH | | |
| Brake | | 3-46 |
| | Brake chatters or hums | 3-46-M3 |
| | Brake does not release | 3-46-M1 |
| | Brake does not stop | 3-46-M2 |
| | Manual release does not work | 3-46-M4 |
| BOW WINCH | | |
| Bow Winch Motor | | 3-47 |
| | Motor does not start | 3-47-M1 |
| | Motor runs hot | 3-47-M3 |
| | Motor starts but does not come up to speed | 3-47-M2 |
| | Noisy (mechanically) | 3-47-M4 |
| Bow Winch | | 3-45 |
| | Motor does not start | 3-45-M1 |
| | Motor runs shaft does not turn | 3-45-M2 |
| CENTRALIZED HYDRAULIC SYSTEM | | |
| Controller | | 3-80 |
| | Controller does not reset | 3-80-M3 |
| | Device does not start | 3-80-M1 |
| | Device does not stop | 3-80-M2 |
| Hydraulic Power Unit | | 3-79 |
| | Erratic performance | 3-79-M8 |
| | Loss of fluid from pump | 3-79-M2 |
| | Loss of fluid from tank | 3-79-M1 |
| | Motor does not run | 3-79-M4 |
| | Motor runs hot | 3-79-M5 |
| | Motor runs slow | 3-79-M6 |
| | Motor runs too fast | 3-79-M7 |
| | Poor performance | 3-79-M3 |
| | Pressure gage does not indicate pressure | 3-79-M9 |
| GENERATOR | | |
| Generator | | 3-42 |
| | Generator noise | 3-42-M2 |
| | Generator overheats | 3-42-M1 |
| | No output | 3-42-M3 |
| GENERATOR ENGINE | | |
| Abnormal Engine Coolant Operating Temperature | | 3-29 |
| | Above normal | 3-29-M1 |
| | Below normal | 3-29-M2 |

| EQUIPMENT | MALFUNCTION | TABLE |
|----------------------------------|---|---------|
| Abnormal Engine Operation | Detonation | 3-24-M3 |
| | Lack of power | 3-24-M2 |
| | Uneven running or frequent stalling | 3-24-M1 |
| | | 3-24 |
| Excessive Crankcase Pressure | Air from blower or air box | 3-27-M3 |
| | Breather restriction | 3-27-M2 |
| | Cylinder blow-by | 3-27-M1 |
| | Excessive exhaust back pressure | 3-27-M4 |
| Exhaust Smoke Analysis | Black or gray smoke | 3-22-M1 |
| | Blue smoke | 3-22-M2 |
| | White smoke | 3-22-M3 |
| | | 3-22 |
| Hard Starting | Engine will not rotate | 3-23-M1 |
| | Inoperative starting aid at low ambient temperature | 3-23-M5 |
| | Low compression | 3-23-M4 |
| | Low cranking speed | 3-23-M2 |
| | No fuel | 3-23-M3 |
| | | 3-23 |
| High Lubricating Oil Consumption | External leaks | 3-26-M1 |
| | Internal leaks | 3-26-M2 |
| | Oil control at cylinder | 3-26-M3 |
| | | 3-26 |
| HYDROSTARTER | | |
| | Cranking Speed Too Low | 3-32 |
| | Fluid Emerges Around Rubber Boot of Hand Pump | 3-40 |
| | Fluid Emerges from Ends of Starter Control Valve when Starter is Operated | 3-41 |
| | Fluid Emerges from the Reservoir Filler Cap when Starter is Used | 3-39 |
| | Hand Pump Fails to Discharge Fluid | 3-35 |
| | High Pressure in System (3500 psi or above (24,133 kPa) | 3-38 |

| EQUIPMENT | MALFUNCTION | TABLE |
|--|---|---------|
| | Loss of Accumulator Precharge (Nitrogen) | 3-37 |
| | Loss of Fluid Pressure when Engine is not Running | 3-34 |
| | Loss of Fluid from Reservoir | 3-33 |
| | Loss or No Accumulator Pressure | 3-31 |
| | Starter Turns but Engine Does Not | 3-36 |
| | Low or High Exhaust Valve Opening Pressure | 3-30 |
| | High valve opening pressure | 3-30-M2 |
| | Low exhaust valve opening pressure | 3-30-M1 |
| | Low Oil Pressure | 3-28 |
| | Lubricating oil | 3-28-M1 |
| | Oil pump | 3-50-M4 |
| | Poor circulation | 3-28-M2 |
| | Pressure gage and alarm switch | 3-28-M3 |
| | No Fuel or Insufficient Fuel | 3-25 |
| | Air leaks | 2-25-M1 |
| | Faulty fuel pump | 3-25-M3 |
| | Faulty installation | 3-25-M4 |
| | Flow obstruction | 3-25-M2 |
| HEADING SELECTOR | | 3-89 |
| | Dimmer lights inoperative | 3-89-M1 |
| | Selector inoperative or erratic | 3-89-M2 |
| HYDRAULIC STEERING CYLINDER AND ADJUSTABLE LINKS | | 3-87 |
| | Adjustable links loose | 3-87-M3 |
| | Cylinder leaking | 3-87-M2 |
| | Cylinder loose | 3-87-M1 |
| | Rudders not at the same position | 3-87-M4 |

| EQUIPMENT | MALFUNCTION | TABLE |
|---|---|---------|
| MARINE GEAR | | 3-10 |
| | Excessive noise | 3-10-M6 |
| | Harsh engagement | 3-10-M8 |
| | High oil pressure | 3-10-M3 |
| | Low oil pressure | 3-10-M1 |
| | No neutral | 3-10-M7 |
| | No oil pressure | 3-10-M2 |
| | Overheating | 3-10-M4 |
| | Reduced oil pressure | 3-10-M5 |
| MAST HYDRAULIC SYSTEM | | 3-82 |
| | Inoperative | 3-82-M1 |
| | Sluggish operation | 3-82-M2 |
| PROPULSION ENGINE | | |
| Abnormal Engine Coolant Operating Temperature | | 3-8 |
| | Above normal | 3-8-M1 |
| | Below normal | 3-8-M2 |
| Abnormal Engine Operation | | 3-3 |
| | Detonation | 3-3-M3 |
| | Lack of power | 3-3-M2 |
| | Uneven running or frequent stalling | 3-3-M1 |
| Excessive Crankcase Pressure | | 3-6 |
| | Air from blower or air box | 3-6-M3 |
| | Breather restriction | 3-6-M2 |
| | Cylinder blow-by | 3-6-M1 |
| | Excessive exhaust back pressure | 3-6-M4 |
| Exhaust Smoke Analysis | | 3-1 |
| | Black or gray smoke | 3-1-M1 |
| | Blue smoke | 3-1-M2 |
| | White smoke | 3-1-M3 |
| Hard Starting | | 3-2 |
| | Engine will not rotate | 3-2-M1 |
| | Inoperative starting aid at low ambient temperature | 3-2-M5 |
| | Low compression | 3-2-M4 |
| | Low cranking speed | 3-2-M2 |
| | No fuel | 3-2-M3 |

| EQUIPMENT | MALFUNCTION | TABLE |
|--------------|---|--------|
| | High Lubricating Oil Consumption | 3-5 |
| | External leaks | 3-5-M1 |
| | Internal leaks | 3-5-M2 |
| | Oil control at cylinder | 3-5-M3 |
| HYDROSTARTER | | |
| | Cranking Speed Too Low | 3-12 |
| | Fluid Emerges Around Rubber Boot of Hand Pump | 3-20 |
| | Fluid Emerges from Ends of Starter Control Valve when Starter is Operated | 3-21 |
| | Fluid Emerges from the Reservoir Filler Cap when Starter is Used | 3-19 |
| | Hand Pump Fails to Discharge Fluid | 3-15 |
| | High Pressure in System (3500 psi or above (24,133 kPa) | 3-18 |
| | Loss of Accumulator Precharge (Nitrogen) | 3-17 |
| | Loss of Fluid Pressure when Engine is not Running | 3-14 |
| | Loss of Fluid from Reservoir | 3-13 |
| | Loss or No Accumulator Pressure | 3-11 |
| | Starter Turns but Engine Does Not | 3-16 |
| | Low or High Exhaust Valve Opening Pressure | 3-9 |
| | High valve opening pressure | 3-9-M2 |
| | Low exhaust valve opening pressure | 3-9-M1 |
| | Low Oil Pressure | 3-7 |
| | Lubricating oil | 3-7-M1 |
| | Oil pump | 3-7-M4 |
| | Poor circulation | 3-7-M2 |
| | Pressure gage | 3-7-M3 |
| | No Fuel or Insufficient Fuel | 3-4 |
| | Air leaks | 3-4-M1 |
| | Faulty fuel pump | 3-4-M3 |
| | Faulty installation | 3-4-M4 |
| | Flow obstruction | 3-4-M2 |

| EQUIPMENT | MALFUNCTION | TABLE |
|---|--|----------|
| 24 VDC RECTIFIER | | 3-44 |
| | Ammeter | 3-44-M2 |
| | Batteries not charged | 3-44-M1 |
| REMOTE MAGNETIC HEADING SYSTEM | | 3-91 |
| | Dial lights inoperative | 3-91-M3 |
| | Heading selector binding | 3-91-M4 |
| | Incorrect heading | 3-91-M2 |
| | Inoperative (D.C. Distribution Box CP24-1) | 3-91-M1 |
| RUDDER ANGLE INDICATOR AND REPEATBACK TRANSMITTER | | 3-88 |
| | Angle shown on indicator and actual rudder angle differ | 3-88-M3 |
| | Indicator dimmer lights inoperative | 3-88-M2 |
| | Inoperative no incoming power | 3-88-M1 |
| SHIP'S COURSE INDICATOR | | 3-92 |
| | Dial moves sluggishly | 3-92-M6 |
| | Dial response is meaningless; lamps are lit | 3-92-M2 |
| | Dial travels slowly in one direction only | 3-92-M5 |
| | Dial of indicator moves alternately fast and slow; may lock occasionally | 3-92-M7 |
| | Dial of two-speed unit rotates continuously in an increasing direction | 3-92-M4 |
| | Incorrect course | 3-92-M10 |
| | Indicator does not move freely in gimbols | 3-92-M8 |
| | Indicator glass dial | 3-92-M9 |
| | Indicator inoperative (dial does not respond; diesel lamps out) | 3-92-M1 |
| | No response | 3-92-M3 |
| STEERING CONTROLLER | | 3-84 |
| | Hydraulic pump inoperative | 3-84-M1 |
| | Hydraulic pump operating Gyropilot in the pilot house inoperative | 3-84-M3 |
| | Hydraulic pump operating RUN light on steering console in pilothouse not lit | 3-84-M2 |

| EQUIPMENT | MALFUNCTION | TABLE |
|-----------------------------|--|----------|
| STEERING CONTROL PANEL | | 3-90 |
| | Automatic steering controls inoperative erratic | 3-90-M5 |
| | Inoperative Power avail lamps not lit | 3-89-M1 |
| | Steering action erratic | 3-90-M4 |
| | Steering lever moves but rudder does not | 3-90-M3 |
| | Unable to turn on steering pumps | 3-90-M2 |
| STEERING CUB HYDRAULIC PUMP | | 3-85 |
| | Erratic operation of rudder | 3-85-M1 |
| | Pump making noise | 3-85-M5 |
| | Rudder goes hard over | 3-85-M6 |
| | Rudder movement in one direction | 3-85-M2 |
| | Steering system inoperative | 3-85-M3 |
| | System operates sluggishly | 3-85-M4 |
| STEERING SYSTEM | | |
| | Hydraulic Directional Control Valve | 3-86 |
| | Erratic Pressure | 3-86-M1 |
| | Excessive noise or chatter | 3-86-M3 |
| | Low pressure or no pressure | 3-86-2 |
| STERN GATE HYDRAULIC SYSTEM | | 3-81 |
| | Inoperative | 3-81-M1 |
| | Sluggish operation | 3-90-M2 |
| SWITCHBOARD | | 3-43 |
| | Ammeter fails to read | 3-43-M6 |
| | Generators do not parallel properly | 3-43-M12 |
| | Generator fails to build up to rated volt-age | 3-43-M3 |
| | Generator fails to supply power to switch-board, as shown on voltmeter. It should read 450 VAC | 3-43-M2 |
| | Generator frequency meter fails to read | 3-43-M7 |
| | Generator frequency drifts; generator runs irrationally | 3-43-M11 |
| | Ground detector lights | 3-43-M13 |
| | No power to load | 3-43-M5 |
| | Shore power available but not to load | 3-43-M10 |
| | Shore power not available | 3-43-M9 |
| | Starter cranks generator but stops when start switch is released | 3-43-M1 |
| | Voltmeter reading too high or too low | 3-43-M4 |
| | Watt meter fails to read | 3-43-M8 |

Table 3-1. Propulsion Engine Exhaust Smoke Analysis
Troubleshooting.

| MALFUNCTION | TEST OR INSPECTION | CORRECTIVE ACTION |
|-------------|--------------------|-------------------|
|-------------|--------------------|-------------------|

- 1 Black or grey smoke observed.
Step 1. Check for high exhaust back pressure which is caused by faulty exhaust piping or muffler obstruction.
Refer to Direct Support Maintenance.

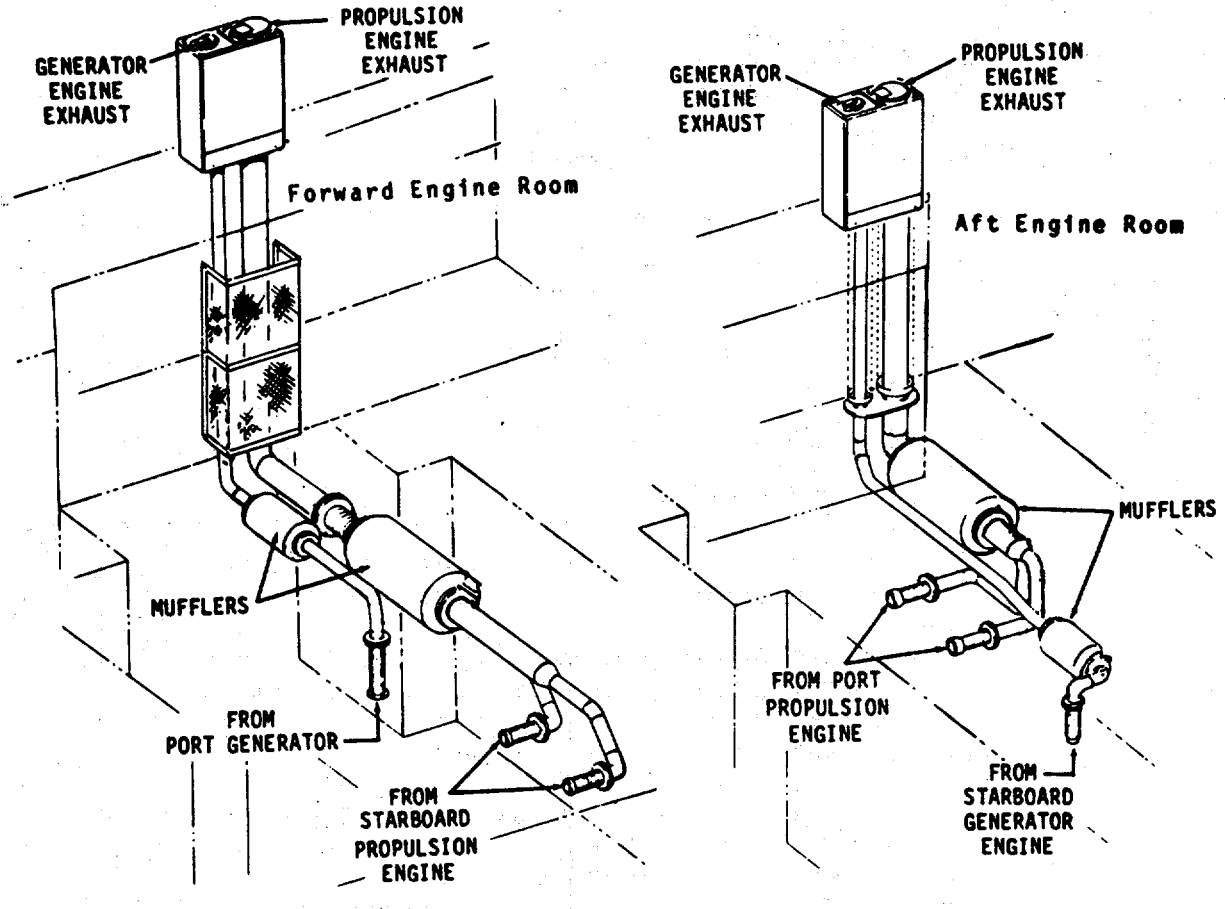

Table 3-1. Propulsion Engine Exhaust Smoke Analysis
Troubleshooting (Cont).

| MALFUNCTION | TEST OR INSPECTION | CORRECTIVE ACTION |
|-------------|--------------------|-------------------|
|-------------|--------------------|-------------------|

1. Black or grey smoke observed (Cont).

Step 2. Check for restricted air inlet to the engine cylinders.

Remove air box covers. Clean ports in cylinder liners. Refer to paragraph 3-40.

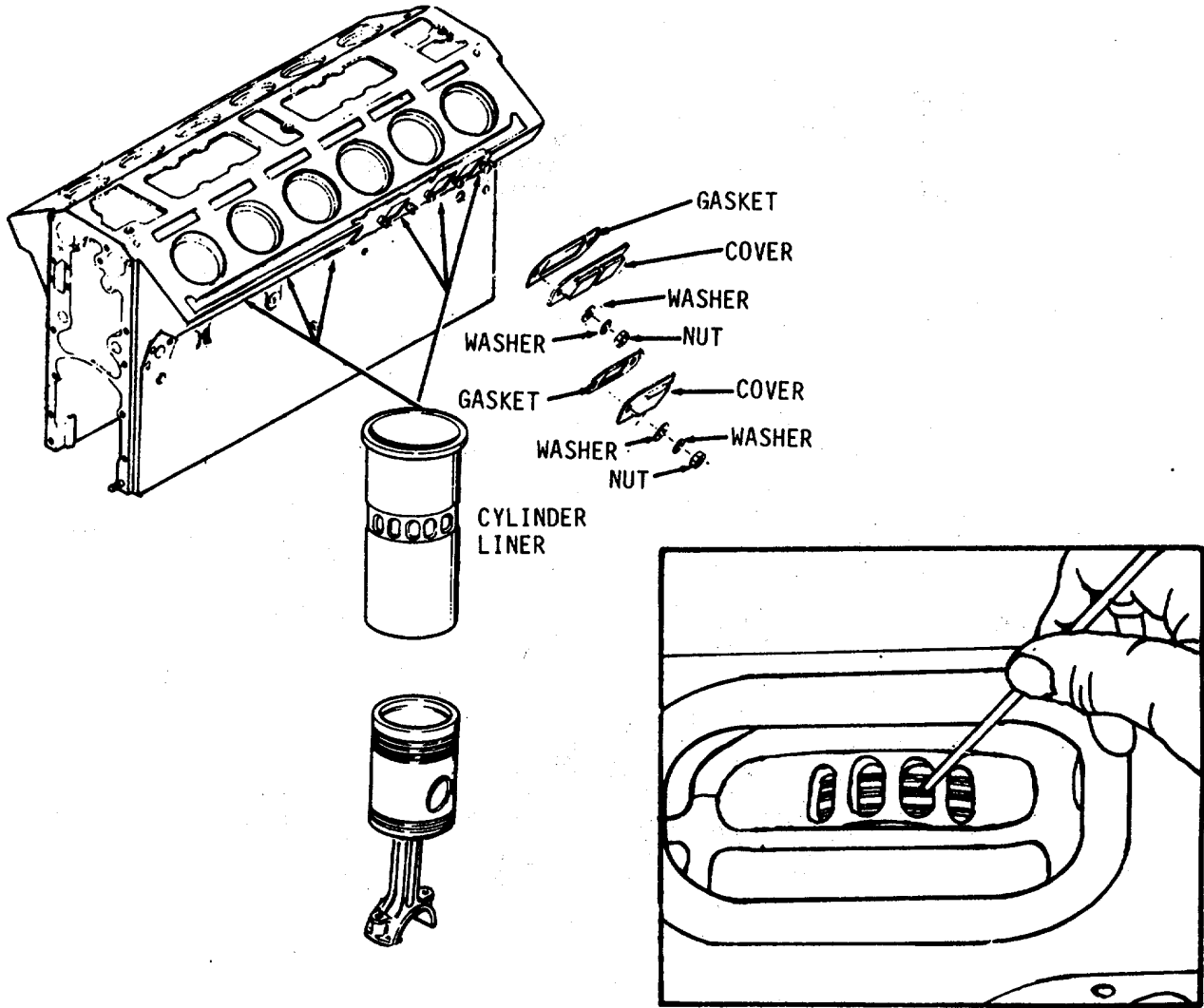

Table 3-1. Propulsion Engine Exhaust Smoke Analysis
Troubleshooting (Cont).

| MALFUNCTION | TEST OR INSPECTION | CORRECTIVE ACTION |
|-------------|--------------------|-------------------|
|-------------|--------------------|-------------------|

1. Black or grey smoke observed (Cont).

Step 3. Check air silencer or blower air inlet screen.
Clean. Refer to paragraph 3-21 and 3-12.

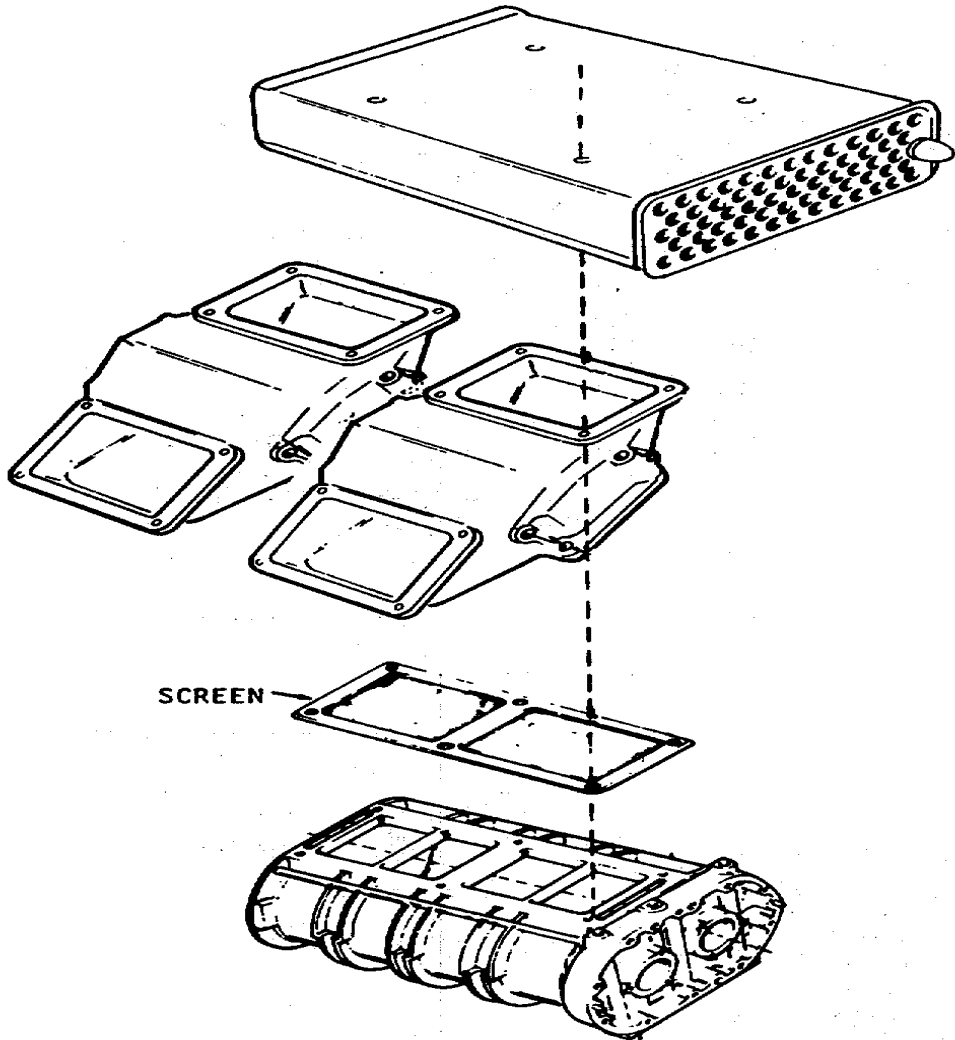

Table 3-1. Propulsion Engine Exhaust Smoke Analysis Troubleshooting (Cont).

| MALFUNCTION | TEST OR INSPECTION | CORRECTIVE ACTION |
|-------------|--------------------|-------------------|
|-------------|--------------------|-------------------|

- 1. Black or grey smoke observed (Cont).
 - Step 4. Check the emergency stop to make sure that it is completely open.
Readjust it if necessary.

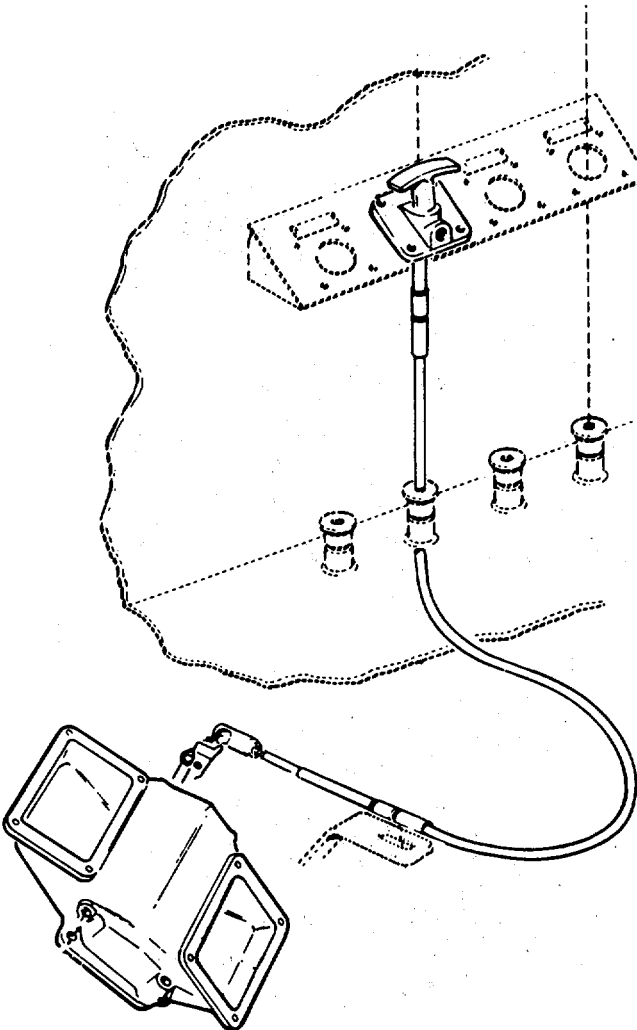

Table 3-1. Propulsion Engine Exhaust Smoke Analysis
Troubleshooting (Cont).

| MALFUNCTION | TEST OR INSPECTION | CORRECTIVE ACTION |
|-------------|--------------------|-------------------|
|-------------|--------------------|-------------------|

- 2. Black or gray smoke caused by excessive fuel or irregular fuel distribution .
Step 1. Check for improperly timed injectors and improperly positioned injector rack control levers.
Time the fuel injectors. Refer to paragraph 3-31.

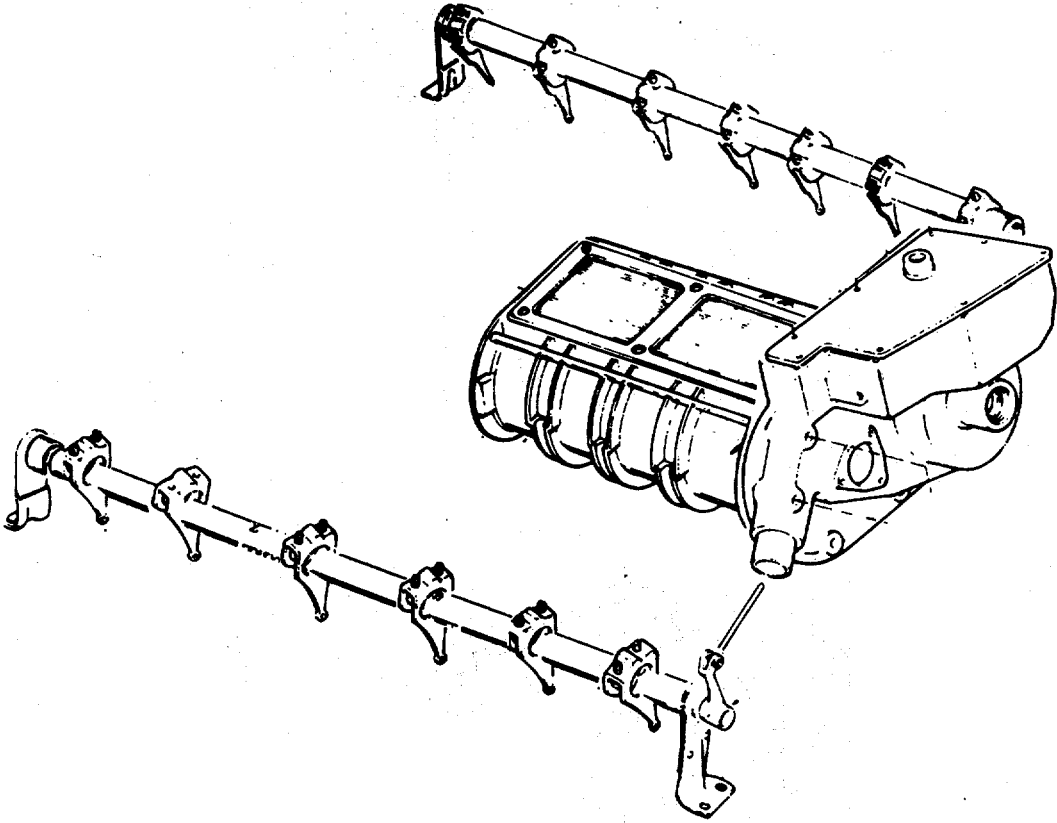

Table 3-1. Propulsion Engine Exhaust Smoke Analysis
 Troubleshooting (Cont).

| MALFUNCTION | TEST OR INSPECTION | CORRECTIVE ACTION |
|-------------|--------------------|-------------------|
|-------------|--------------------|-------------------|

2. Black or gray smoke caused by excessive fuel or irregular fuel distribution (Cont).

Step 2. If this condition still persists after timing the injectors.

Replace faulty injectors. Refer to paragraph 3-15.

NOTE

Avoid lugging the engine as this will cause incomplete combustion. If problem remains, refer to Direct Support Maintenance.

3. Black or gray smoke caused by improper grade of fuel.

Check for use of an improper grade of fuel:

DIESEL FUEL

| TYPE | NATIONAL STOCK NUMBER |
|----------------|-----------------------|
| ARTIC (DF-A) | 9140-00-286-5283 |
| WINTER (DF-W) | 9140-00-286-5286 |
| REGULAR (DF-2) | 9140-00-286-5294 |

4. Blue smoke.

Check for internal lubricating oil leaks.
 Lubricating oil not burned in cylinder (blown through cylinder during scavenging period. Refer to the High Lubricating Oil Consumption Table 3-5.

Table 3-1. Propulsion Engine Exhaust Smoke Analysis
Troubleshooting (Cont).

| MALFUNCTION | TEST OR INSPECTION | CORRECTIVE ACTION |
|-------------|--------------------|-------------------|
|-------------|--------------------|-------------------|

5 White Smoke.

- | | |
|---------|---|
| Step 1. | Check for faulty injectors. Replace as necessary. Refer to paragraph 3-15. |
| Step 2. | Check for low compression. Consult the Hard Starting Table 3-2. |

Table 3-2. Propulsion Engine Hard Starting
Troubleshooting.

| MALFUNCTION | TEST OR INSPECTION | CORRECTIVE ACTION |
|-------------|--------------------|-------------------|
|-------------|--------------------|-------------------|

1. Engine will not rotate.

- | | |
|---------|--|
| Step 1. | Check hydrostarter. Refer to tables 3-16 through 3-21, and perform the operations listed. |
| Step 2. | Check for defective starting motor switch in either the pilot house or engine room. Replace the starting motor switch. Refer to paragraph 3-25. |
| Step 3. | Check for internal seizure. Crank the engine at least one complete revolution. If the engine cannot be rotated a complete revolution, internal damage is indicated and the engine must be disassembled to ascertain the extent of damage and the cause. Refer to paragraph 3-7. |

Table 3-2. Propulsion Engine Hard Starting
 Troubleshooting (Cont).

| MALFUNCTION | TEST OR INSPECTION | CORRECTIVE ACTION |
|-------------|--------------------|-------------------|
|-------------|--------------------|-------------------|

2. Low cranking speed.

- Step 1. Check for improper lubricating oil viscosity.
 Use the recommended grade of oil.

LUBRICATING OIL GRADES

| DESCRIPTION | SPECIFICATION |
|----------------|---------------|
| OES (Sub Zero) | MIL-L-10295 |
| OE/HDO 10 | MIL-L-2104 |
| OE/HDO 20 | MIL-L-2104 |
| OE/HDO 30 | MIL-L-2104 |

NOTE

At low ambient temperatures, use of a starting aid will reduce the cranking time.

- Step 2. Check for loose hydrostarter connections or faulty starter.
 Tighten the starter connections. Refer to tables 3-15 through 3-21 for hydrostarter problems.

3. No fuel.

- Step 1. Check for air leaks, flow obstruction, faulty fuel pump, and faulty installation.
 To check for air leaks, flow obstruction, faulty fuel pump or faulty installation, consult the NO Fuel or Insufficient Fuel Table 3-4.

Table 3-2. Propulsion Engine Hard Starting Troubleshooting (Cont).

| MALFUNCTION | TEST OR INSPECTION | CORRECTIVE ACTION |
|-------------|--------------------|-------------------|
|-------------|--------------------|-------------------|

3. No fuel (Cont).

Step 2. Check for injector racks not in full-fuel position.

Check for bind in the governor-to-injector linkage. Readjust the governor and injector controls if necessary. Refer to paragraphs 3-10 and 3-31.

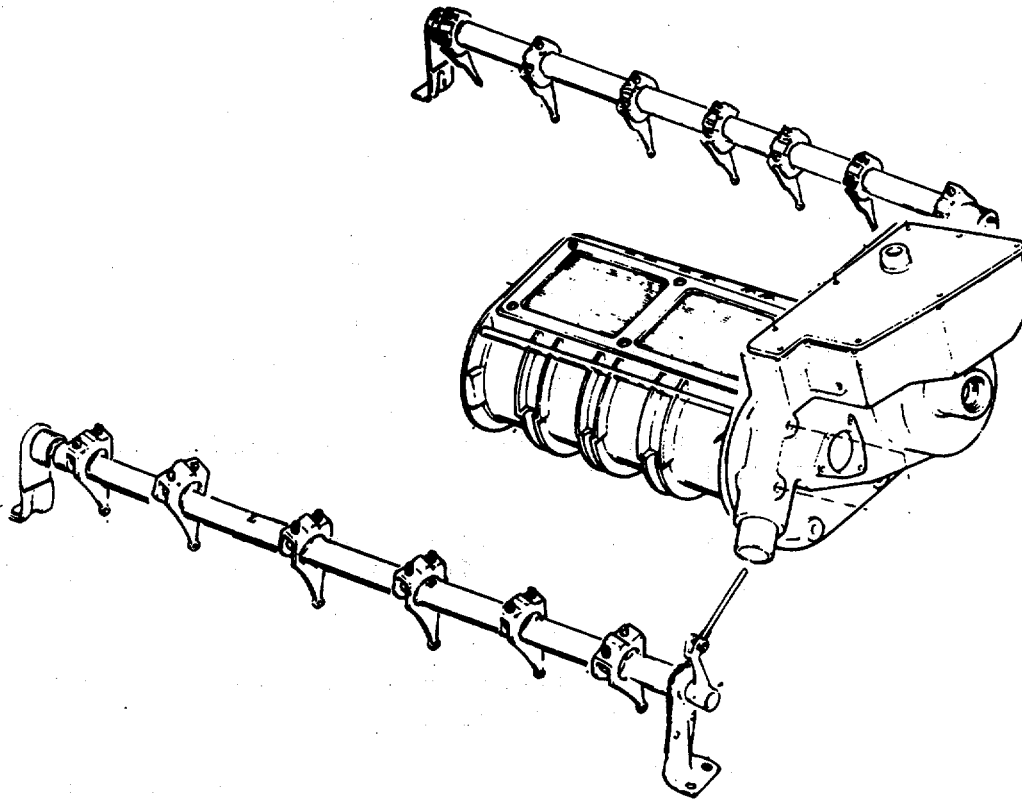

4. Low compression.

Step 1. Check for exhaust valves that are sticking or burned. Remove the cylinder head and recondition the exhaust valves. Refer to paragraph 3-34.

Table 3-2. Propulsion Engine Hard Starting
Troubleshooting (Cont).

| MALFUNCTION | TEST OR INSPECTION | CORRECTIVE ACTION |
|-------------|--------------------|-------------------|
|-------------|--------------------|-------------------|

- 4. Low compression (Cont).
Step 2. Check for Compression rings that are worn or broken.

Remove the air box covers and inspect the compression rings through the ports in the cylinder liners. Overhaul the cylinder assemblies if the rings are badly worn or broken. Refer to paragraph 3-40.

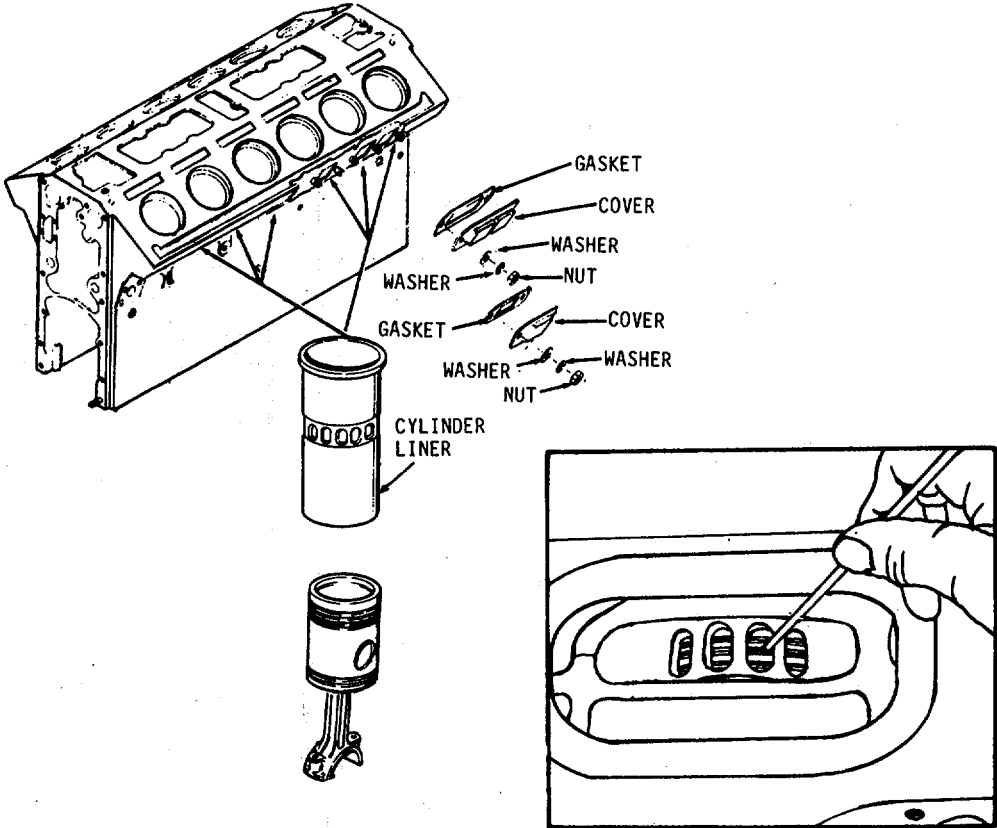

Table 3-2. Propulsion Engine Hard Starting Troubleshooting (Cont).

| MALFUNCTION | TEST OR INSPECTION | CORRECTIVE ACTION |
|-------------|--------------------|-------------------|
|-------------|--------------------|-------------------|

4. Low compression (Cont).

Step 3. Check for cylinder head gasket leaking.

To check for compression gasket leakage, remove the coolant filler-cap and operate the engine. A steady flow of gases from the coolant filler indicates either a cylinder head gasket is damaged or the cylinder head is cracked. Remove the cylinder head and replace the gaskets or cylinder head. Refer to paragraph 3-34.

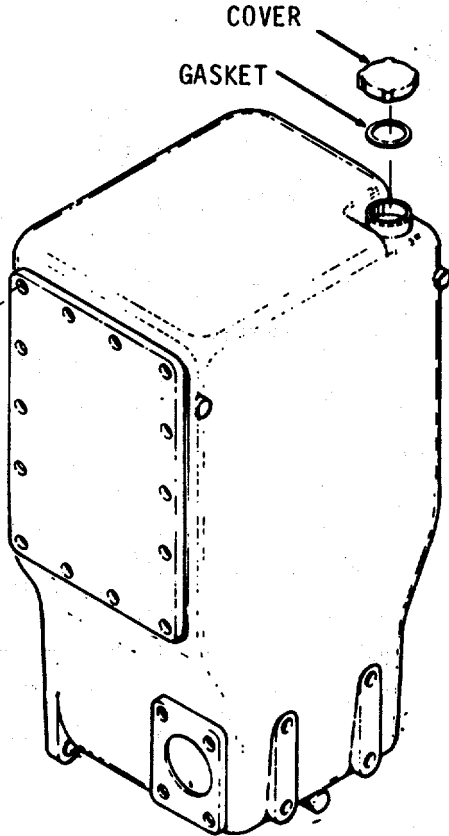

Table 3-2. Propulsion Engine Hard Starting
Troubleshooting (Cont).

| MALFUNCTION | TEST OR INSPECTION | CORRECTIVE ACTION |
|-------------|--|--|
| 4. | Low compression (Cont). Step 4. Check for improper valve clearance adjustment. | Adjust the exhaust valve clearance. Refer to paragraph 3-33. |
| | Step 5. Check for blower not functioning. Inspect the blower drive shaft and drive coupling. | Refer to paragraph 3-12. |
| 5. | Inoperative starting aid at low ambient temperatures. Check for improper operation of fluid starting aid. | Operate the starting aid. Refer to paragraph 2-30. |

Table 3-3. Propulsion Engine Abnormal Engine Operation
Troubleshooting.

| MALFUNCTION | TEST OR INSPECTION | CORRECTIVE ACTION |
|-------------|--|--|
| 1. | Uneven running or frequent stalling. Step 1. Check for low coolant temperature. | Check the engine coolant temperature gage and if the temperature does not reach 160° F to 185° F (71° to 85° C), while the engine is operating, consult the Abnormal Engine Coolant Temperature table 3-8. |

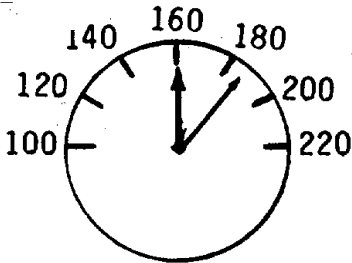

Table 3-3. Propulsion Engine Abnormal Engine Operation
Troubleshooting (Cont).

| MALFUNCTION | TEST OR INSPECTION | CORRECTIVE ACTION |
|-------------|--------------------|-------------------|
|-------------|--------------------|-------------------|

1. Uneven running or frequent stalling (Cont).

Step 2. Check for insufficient fuel.

Check engine fuel spill back, and if the return is less than 0.8 gallons per minute with engine at 1200 RPM, consult the No Fuel or Insufficient Fuel table 3-4.

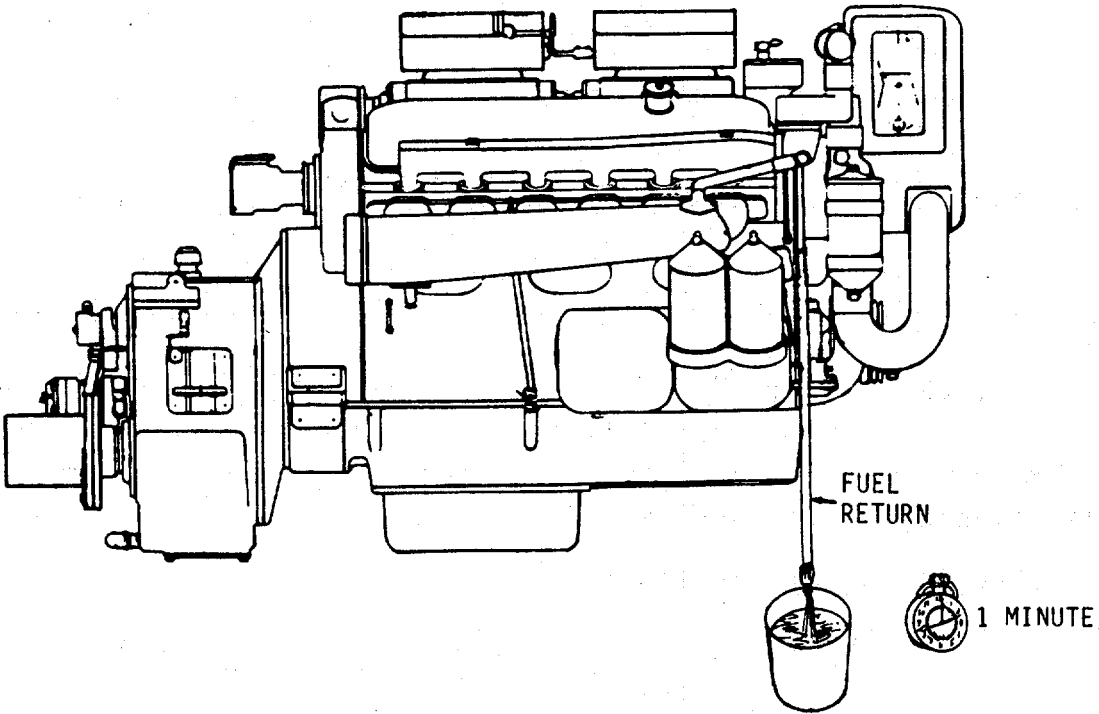

Table 3-3. Propulsion Engine - Abnormal Engine Operation
 Troubleshooting (Cont)

| MALFUNCTION | TEST OR INSPECTION | CORRECTIVE ACTION |
|-------------|--------------------|-------------------|
|-------------|--------------------|-------------------|

1. Uneven running or frequent stalling (Cont)

Step 3. Check for faulty injectors, timing and the position of the injector racks.

Refer to paragraph 3-31.

Erratic engine operation may also be caused by leaking injector spray tips. Replace the faulty injectors. Refer to paragraph 3-15.

Step 4. Check for low compression pressures within the cylinders.

Consult the Hard Starting table 3-2 if compression pressures are low.

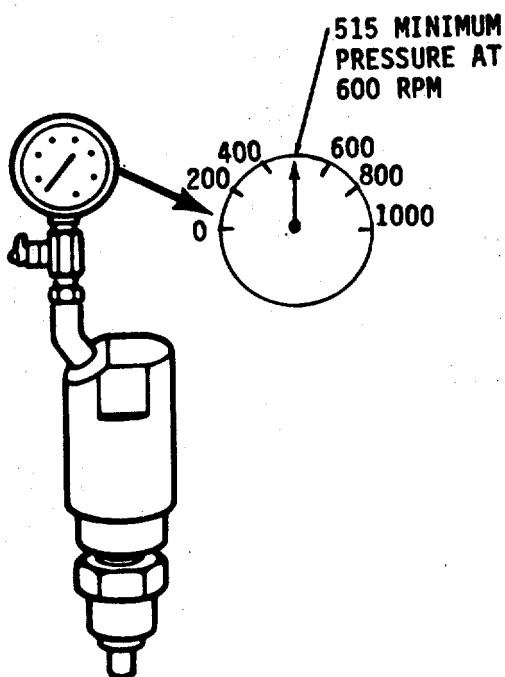

Table 3-3. Propulsion Engine - Abnormal Engine Operation
 Troubleshooting (Cont).

| MALFUNCTION | TEST OR INSPECTION | CORRECTIVE ACTION |
|-------------|--------------------|-------------------|
|-------------|--------------------|-------------------|

1. Uneven running or frequent stalling (Cont).

Step 5. Check for governor instability (hunting). Erratic engine operation may be caused by governor- to-injector operating linkage bind or by engine misadjustment. Refer to paragraph 3-10.

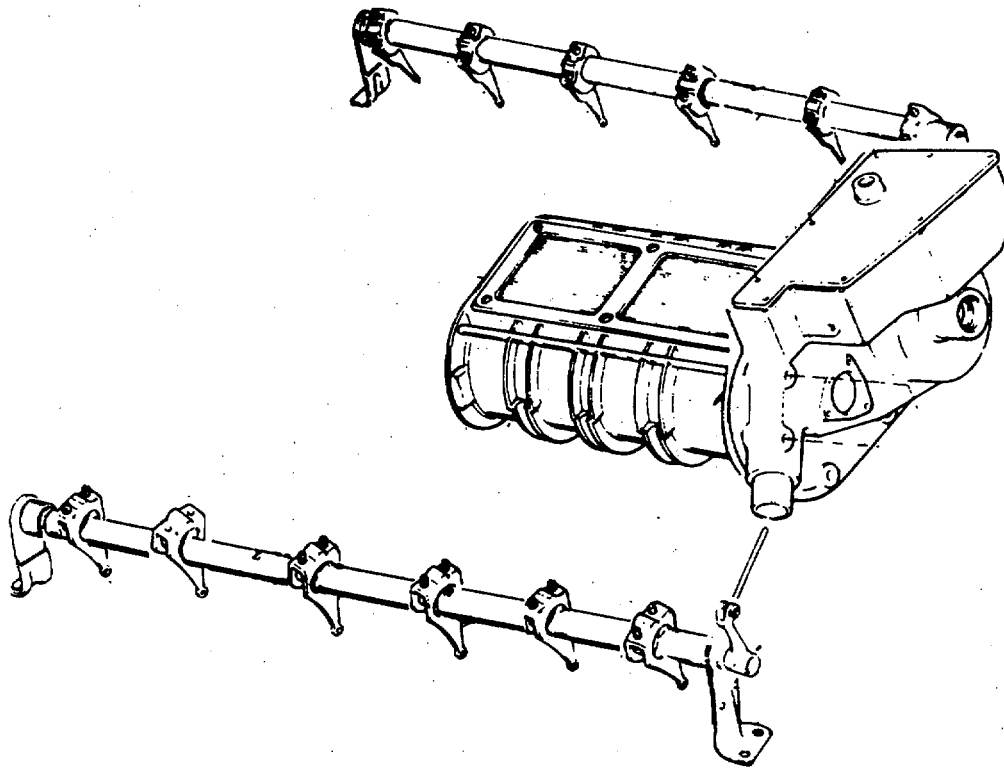

Table 3-3. Propulsion Engine - Abnormal Engine Operation
 Troubleshooting (Cont).

| MALFUNCTION | TEST OR INSPECTION | CORRECTIVE ACTION |
|-------------|--------------------|-------------------|
|-------------|--------------------|-------------------|

2. Lack of power.

Step 1. Check for improper engine adjustments and gear train timing.

Perform adjustments in paragraphs 3-9, 3-10, 3-31, 3-33, and 3-36, if performance is not satisfactory.

Check the engine gear train timing. An improperly timed gear train will result in a loss of power due to the valves and injectors being actuated at the wrong time in the engine's operating cycle. Refer to paragraph 3-33.

Step 2. Check for insufficient fuel.

Perform a Fuel Flow Test and, if less than 0.8 gallons per minute with engine at 1200 RPM, consult the No Fuel or Insufficient Fuel Table 3-4.

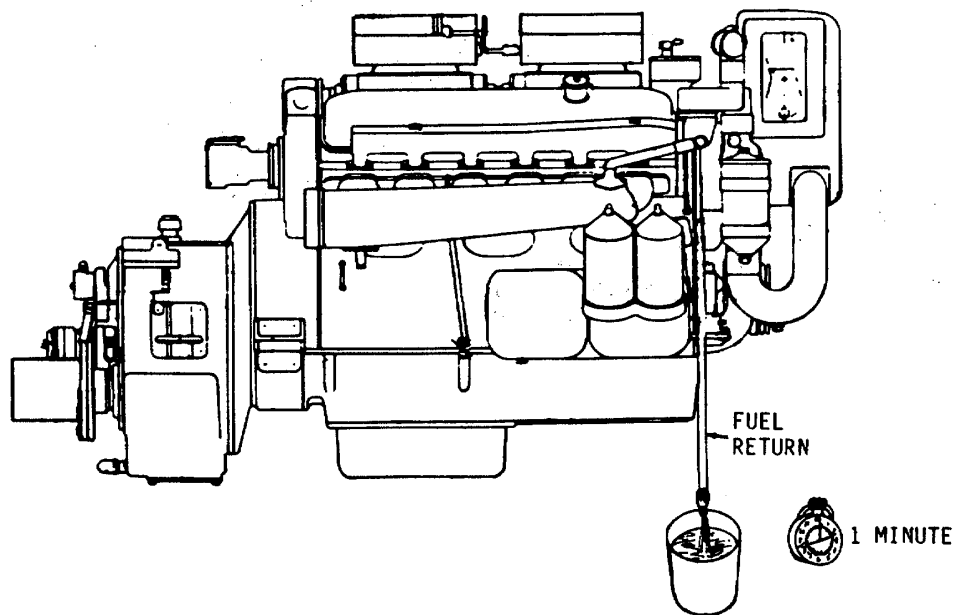

Table 3-3. Propulsion Engine - Abnormal Engine Operation
 Troubleshooting (Cont).

| MALFUNCTION | TEST OR INSPECTION | CORRECTIVE ACTION |
|-------------|--------------------|-------------------|
|-------------|--------------------|-------------------|

2. Lack of power (Cont).

Step 3. Check for insufficient air.

a. Check for damaged or dirty air silencers.

Clean, repair or replace damaged parts.

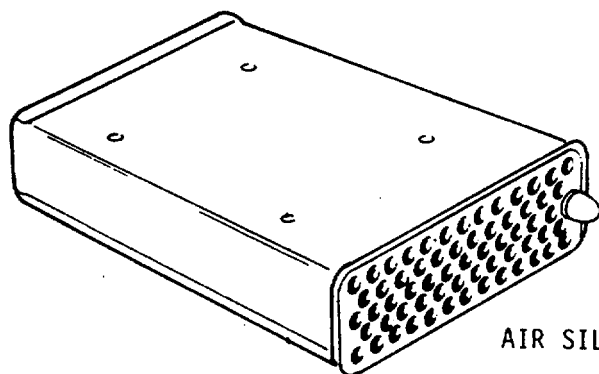

AIR SILENCER

Table 3-3. Propulsion Engine - Abnormal Engine Operation
 Troubleshooting (Cont).

| MALFUNCTION | TEST OR INSPECTION | CORRECTIVE ACTION |
|-------------|--------------------|-------------------|
|-------------|--------------------|-------------------|

2. Lack of power (Cont).

b. Remove the air box covers and inspect the cylinder liner ports.

Clean the ports if they are over 50% plugged.

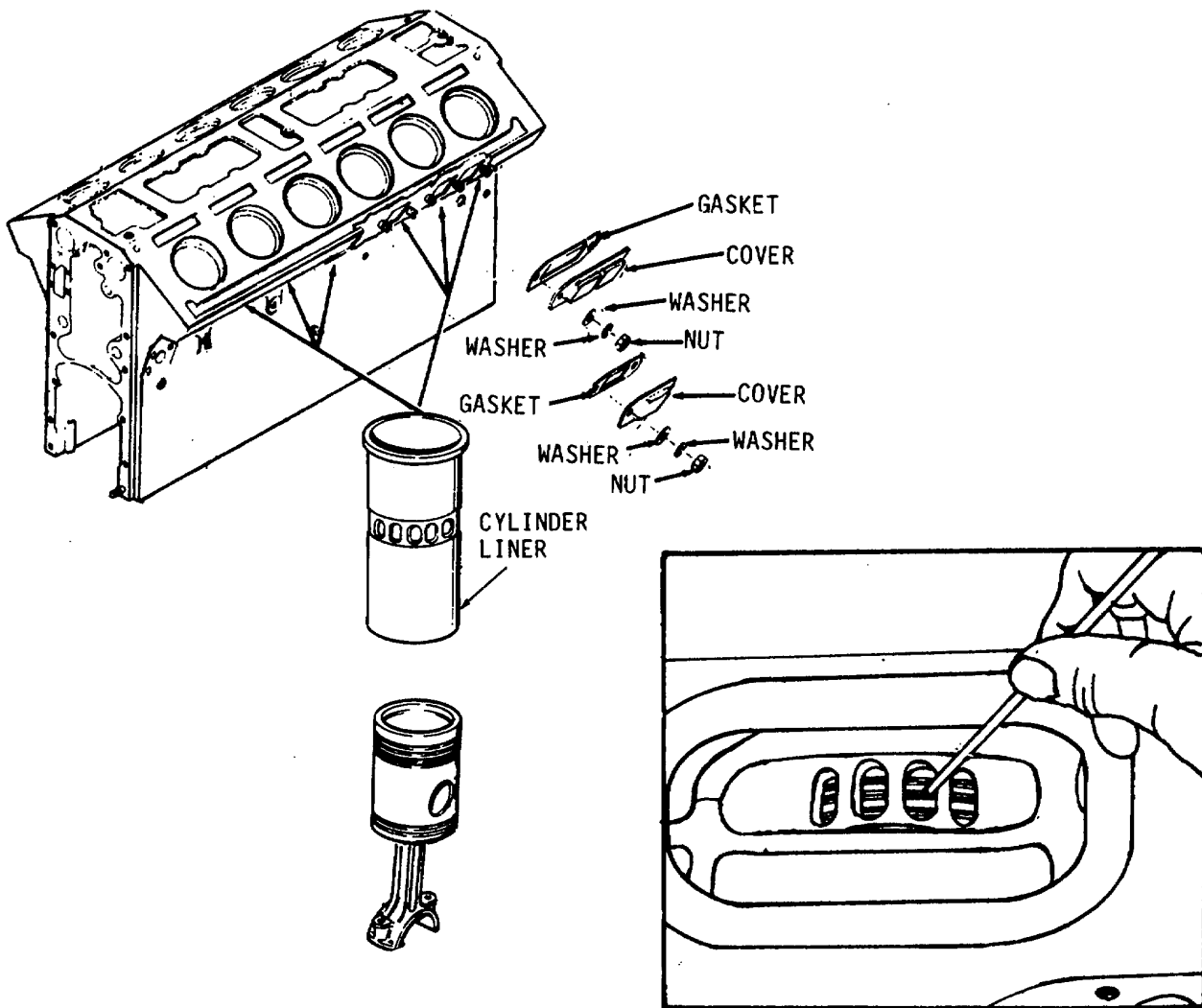

Table 3-3. Propulsion Engine - Abnormal Engine Operation
 Troubleshooting (Cont).

| MALFUNCTION | TEST OR INSPECTION | CORRECTIVE ACTION |
|-------------|--------------------|-------------------|
|-------------|--------------------|-------------------|

2. Lack of power (Cont).

- c. Check for blower air intake obstruction or high exhaust back pressure.
 Clean, repair or replace faulty parts.

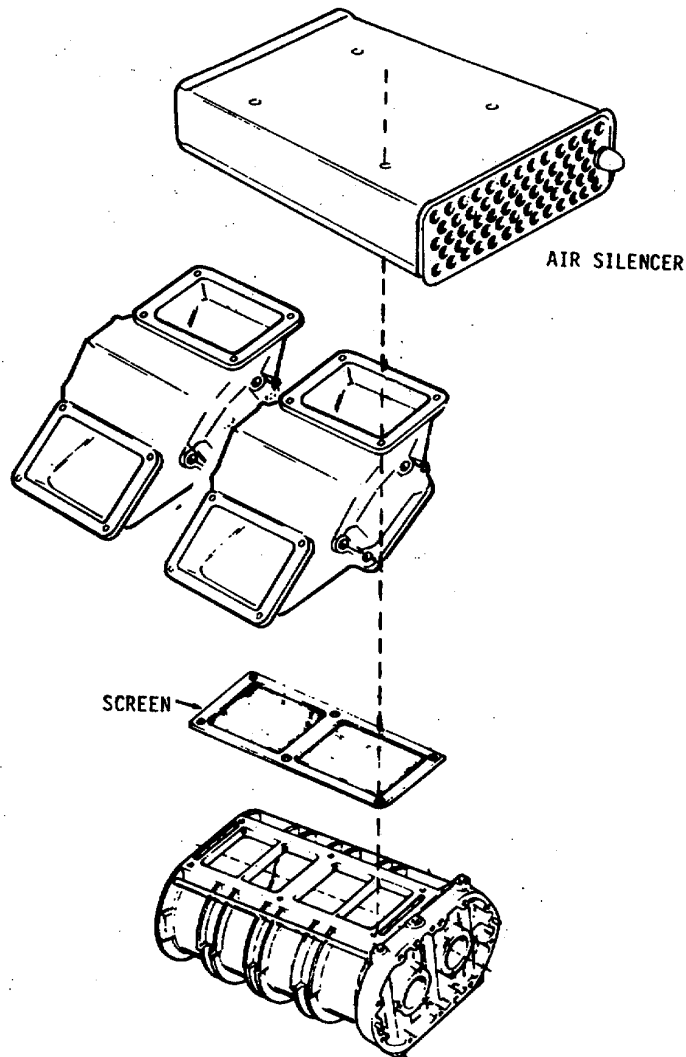

Table 3-3. Propulsion Engine - Abnormal Engine Operation

Troubleshooting (Cont).

| MALFUNCTION | TEST OR INSPECTION | CORRECTIVE ACTION |
|-------------|--------------------|-------------------|
|-------------|--------------------|-------------------|

2. Lack of power (Cont).

d. Check the compression pressures.

Refer to the Hard Starting Table 3-2.

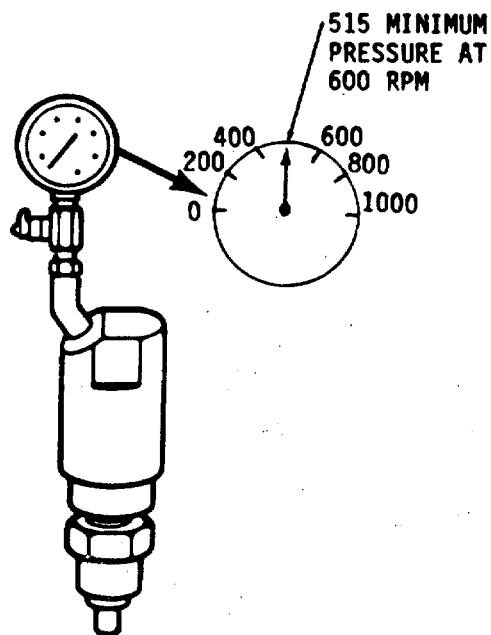

Step 4. Engine application.

Check for incorrect operation of the engine which may result in excessive loads on the engine.

Operate the engine according to the approved procedures.

Table 3-3. Propulsion Engine - Abnormal Engine Operation
 Troubleshooting (Cont).

| MALFUNCTION | TEST OR INSPECTION | CORRECTIVE ACTION |
|-------------|-----------------------|---|
| 2. | Lack of power (Cont). | <p>Step 5. Check for high return fuel temperature.</p> <p>Refer to table 3-4.</p> <p>Step 6. Check for high ambient air temperature.</p> <p>Check the ambient air temperature. A power decrease of .15 to .50 horsepower per cylinder, depending upon injector size, for each 10°F(5.5°C) temperature rise above 90° F will occur.</p> <p>Operate ventilation fans to provide a cooler source of air.</p> |
| 3. | Detonation. | <p>Step 1. Check for oil picked up by air stream.</p> <p>a. Clean the air box and drain tubes to prevent accumulations that may be picked up by the air stream and enter the engine's cylinders.</p> |

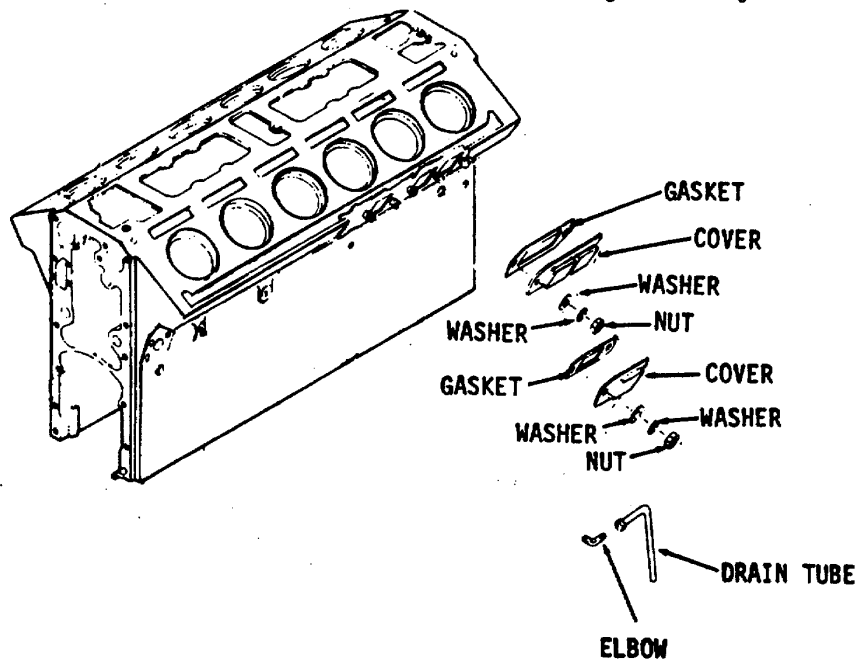
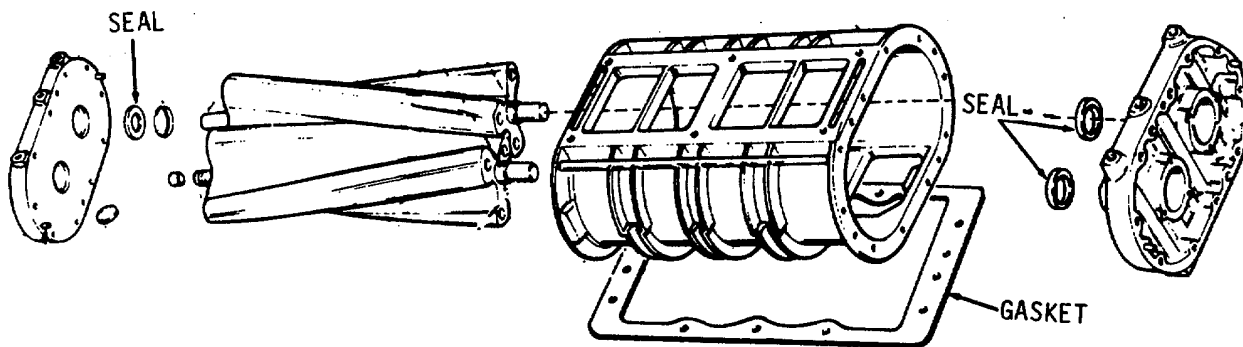

Table 3-3. Propulsion Engine - Abnormal Engine Operation
 Troubleshooting (Cont).

| MALFUNCTION | TEST OR INSPECTION | CORRECTIVE ACTION |
|-------------|--------------------|-------------------|
|-------------|--------------------|-------------------|

3. Detonation (Cont).

- b. Inspect the blower oil seals by removing the air inlet housing and watching through the blower inlet for oil radiating away from the blower rotor shaft oil seals while the engine is running. If oil is passing through the seals, refer to Direct Support Maintenance.



- c. Check for a defective blower-to-block gasket.
 Replace the gasket. Refer to paragraph 3-12.

Step 2. Check for low coolant temperature.

Refer to MALFUNCTION 1.

Step 3. Check for faulty injectors.

- a. Check injector timing and the position of each injector rack. Refer to paragraphs 3-15 and 3-31. The erratic operation may be caused by an injector check valve leaking, spray tip holes enlarged or a broken spray tip. Replace faulty injectors. Refer to paragraph 3-15.

Table 3-4. Propulsion Engine - No Fuel or Insufficient Fuel

Troubleshooting.

Refer to Figure 3-1 for Fuel System Piping.

| MALFUNCTION | TEST OR INSPECTION | CORRECTIVE ACTION |
|-------------|--------------------|-------------------|
|-------------|--------------------|-------------------|

1. Air leaks.

Step 1. Check for low fuel supply.

The fuel tank should be filled above the level of the fuel suction tube.

Step 2. Check for loose connections or cracked lines between fuel pump and tank or suction line in tank.

Perform a Fuel Flow Test and, if air is present, tighten loose connections and replace cracked lines. Refer to paragraph 3-14.

NOTE

Fuel Flow should be 0.8 gallons per minute with engine at 1200 RPM.

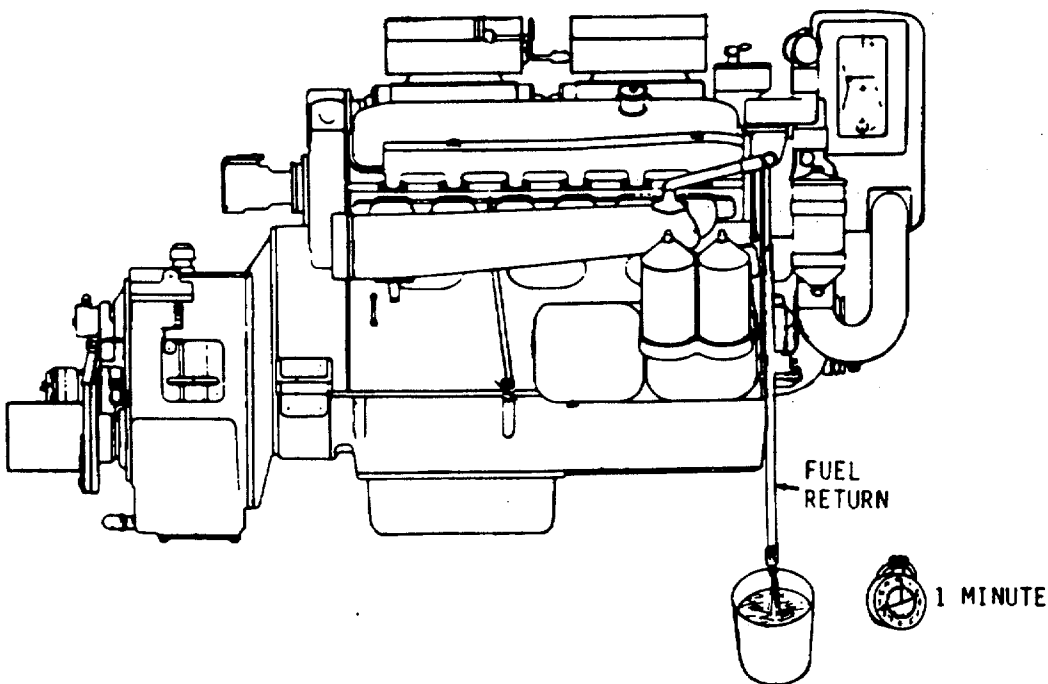

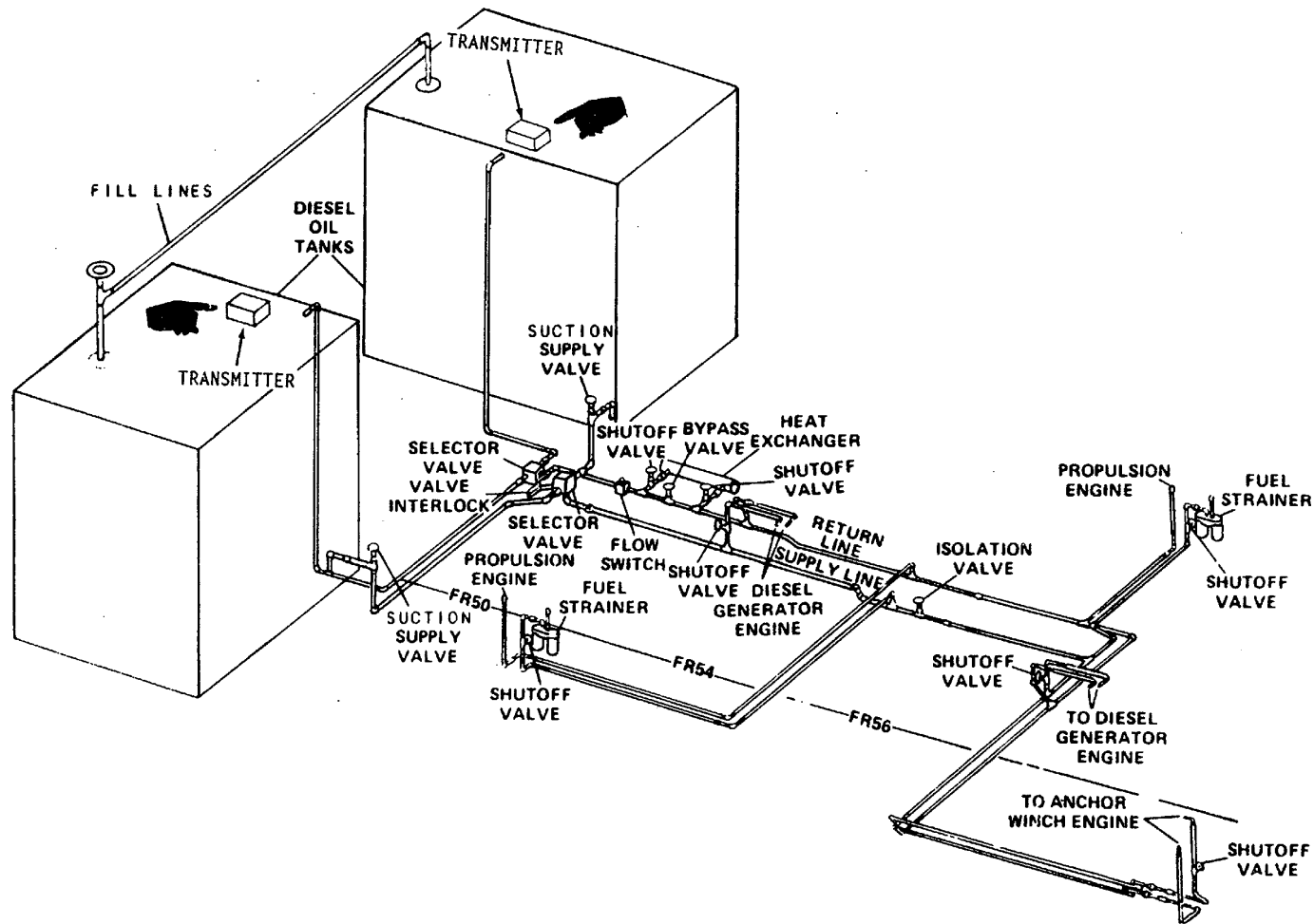

Figure 3-1. Fuel System Piping

Change 2 3-39

Table 3-4. Propulsion Engine - No Fuel or Insufficient Fuel

Troubleshooting (Cont).

Refer to Figure 3-1 for Fuel System Piping.

MALFUNCTION

TEST OR INSPECTION

CORRECTIVE ACTION

1. Air leaks (Cont).

Step 3. Check for damaged fuel oil strainer gasket. Perform a Fuel Flow Test and, if air is present, replace the fuel strainer gasket when changing the strainer element. Refer to paragraph 3-14.

Step 4. Check for faulty injector tip assembly.
Perform a Fuel Flow Test and, if air is present with all fuel lines and connections assembled correctly, check for and replace faulty injectors. Refer to paragraph 3-15.

2. Flow obstruction.

Step 1. Check the fuel strainer or lines for restrictions.
Perform a Fuel Flow Test and replace the fuel strainer and filter elements and the fuel lines, if necessary. Refer to paragraph 3-14.

Step 2. Check for temperature less than 100°F(5.50°C) pour point of fuel.

Use the Proper Grade of Fuel

DIESEL FUEL

| TYPE | NATIONAL STOCK NUMBER |
|----------------|-----------------------|
| ARTIC (DF-A) | 914X0-00-286-5283 |
| WINTER (DF-W) | 9140-00-286-5286 |
| REGULAR (DF-2) | 9140-00-286-5294 |

Table 3-4. Propulsion Engine - No Fuel or Insufficient Fuel
 Troubleshooting (Cont).

| MALFUNCTION | TEST OR INSPECTION | CORRECTIVE ACTION |
|-------------|--------------------|-------------------|
|-------------|--------------------|-------------------|

3. Faulty fuel pump.

Step 1. Check for relief valve not seating.

Perform a Fuel Oil Test and, if inadequate, clean and inspect the valve seat assembly. Refer to paragraph 3-13.

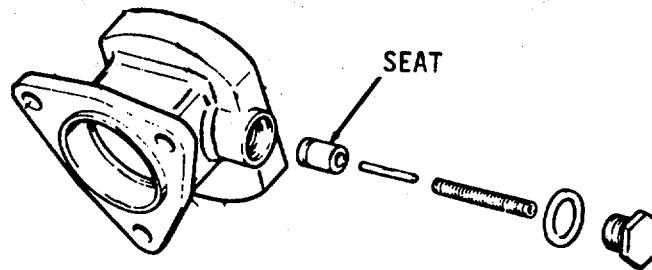

Step 2. Check for worn gears or pump body.

Replace the gear and shaft assembly or the pump body. Refer to paragraph 3-13.

Step 3. Check for fuel pump not rotating.

Check the condition of the fuel pump drive and blower drive and replace defective parts. Refer to paragraphs 3-10, 3-12 and 3-13.

Table 3-4. Propulsion Engine - No Fuel or Insufficient Fuel

Troubleshooting (Cont).

| MALFUNCTION | TEST OR INSPECTION | CORRECTIVE ACTION |
|-------------|--------------------|-------------------|
|-------------|--------------------|-------------------|

4. Faulty installation.

- Step 1. Check for restricted fitting missing from return line.
Install a restricted elbow fitting in the return line.

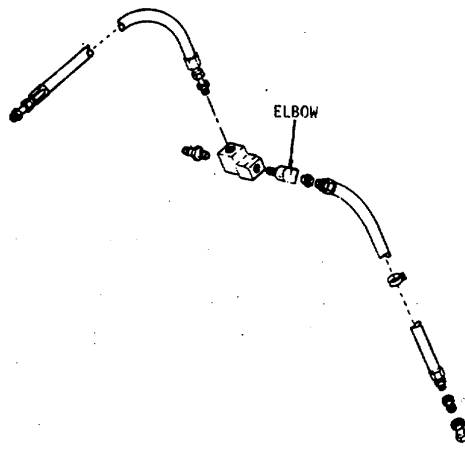

- Step 2. Check for inoperative fuel return line check lift valve.
Make sure that the check lift valve is installed in the line correctly; the arrow should be on top of the valve assembly or pointing upward. Reposition the valve if necessary. If the valve is in- operative, replace it with a new valve assembly. Refer to paragraph 3-14.

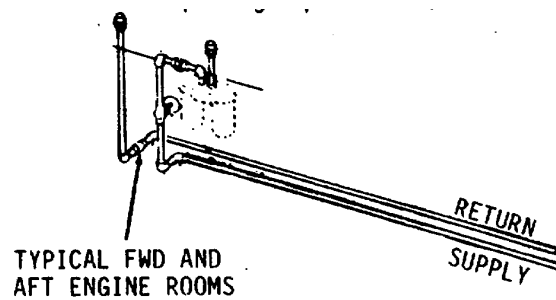

Table 3-4. Propulsion Engine - No Fuel or Insufficient Fuel
 Troubleshooting (Cont).

| MALFUNCTION | TEST OR INSPECTION | CORRECTIVE ACTION |
|-------------|--------------------|-------------------|
|-------------|--------------------|-------------------|

4. Faulty installation (Cont).

Step 3. Check for high fuel return temperature.

Check the engine fuel spill-back temperature. The return fuel temperature must be less than 150° F (65.5 °C) or a loss in horsepower will occur. This condition may be corrected by installing larger fuel lines or using the fuel oil heat exchanger.

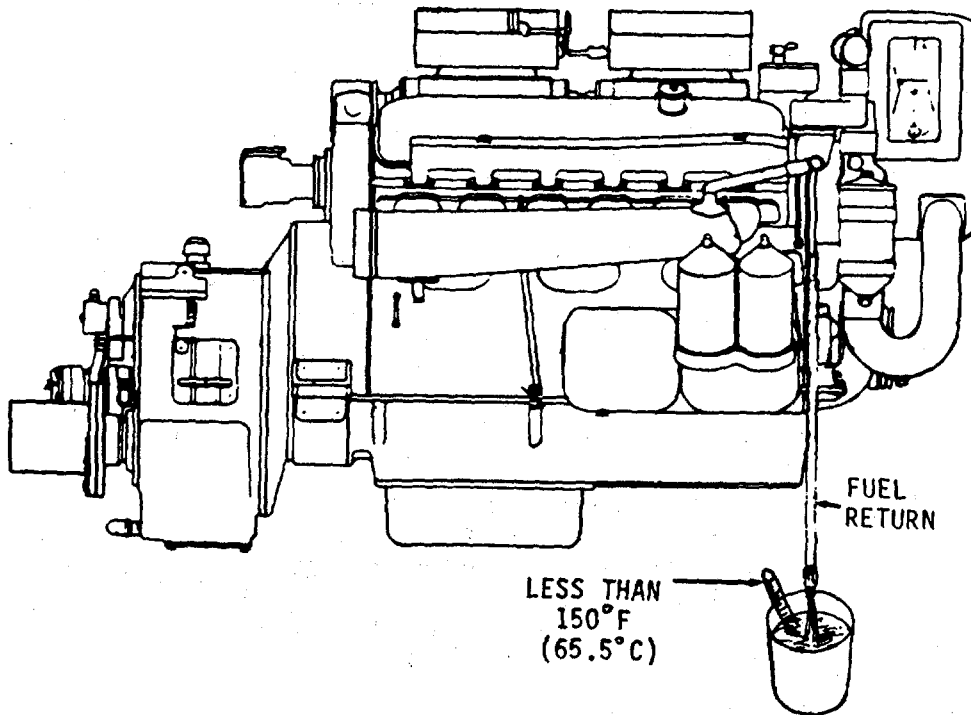

Table 3-5. Propulsion Engine - High Lubricating Oil Consumption
 Troubleshooting.

| MALFUNCTION | TEST OR INSPECTION | CORRECTIVE ACTION |
|-------------|--------------------|-------------------|
|-------------|--------------------|-------------------|

1. External leaks.

- Step 1. Check oil lines or connections for leaking.
 Tighten connections or replace defective parts.
 Refer to paragraph 3-17.

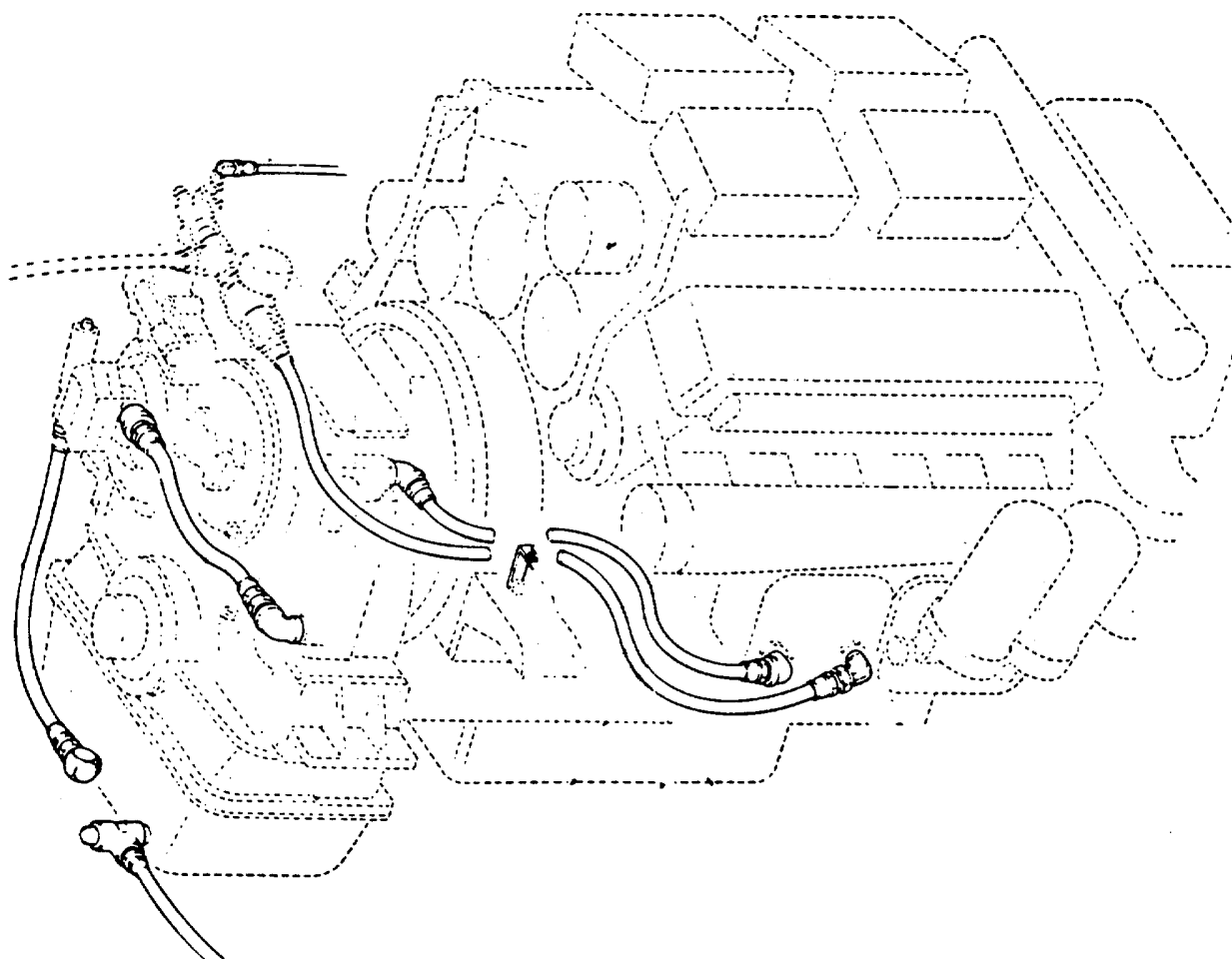

Table 3-5. Propulsion Engine - High Lubricating Oil Consumption
 Troubleshooting (Cont)

| MALFUNCTION | TEST OR INSPECTION | CORRECTIVE ACTION |
|-------------|--------------------|-------------------|
|-------------|--------------------|-------------------|

1. External leaks (Cont)

- Step 2. Check for gasket or oil seal leaks.
 Replace defective gaskets or oil seals. Refer to paragraph 3-17.
- Step 3. Check for high crankcase pressure.
 Refer to the Excessive Crankcase Pressure Table 3-6.
- Step 4. Check for excessive oil in air box.
 Refer to the Abnormal Engine Operation Table 3-3.

2. Internal leaks.

- Step 1. Check blower oil seal for leaking.
 Remove the air inlet housing and inspect the blower end plates while the engine is operating.
 If oil is seen on the end plate radiating away from the oil seal, refer to Direct Support Maintenance.

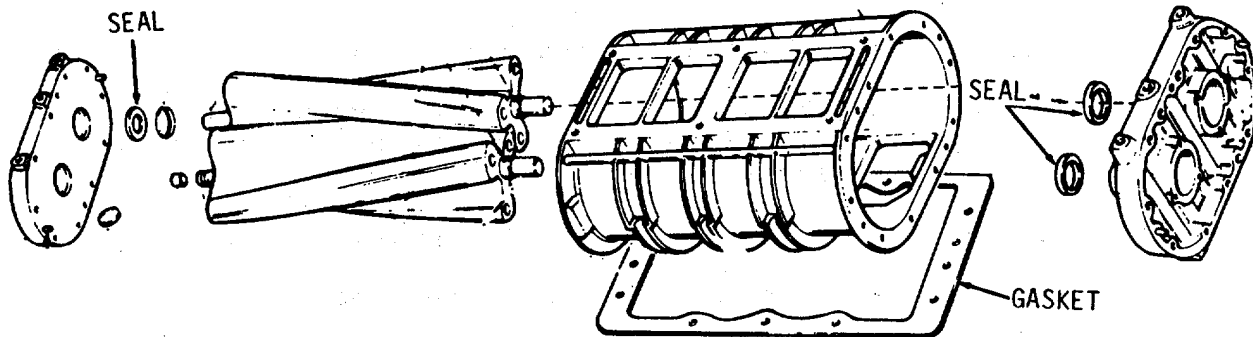

Table 3--5. Propulsion Engine - High Lubricating Oil Consumption
 Troubleshooting (Cont).

| MALFUNCTION | TEST OR INSPECTION | CORRECTIVE ACTION |
|-----------------------------|--------------------|---|
| 2. Internal leaks (Cont). | Step 2. | Check oil cooler core for leaking. Inspect the engine coolant for lubricating oil contamination; if contaminated, replace the oil cooler core. Then use a good grade of cooling system cleaner to remove the oil from the cooling system. Refer to paragraph 3-17. |
| 3. Oil control at cylinder. | Step 1. | Check for oil control rings that are worn, broken or improperly installed. Replace the oil control rings. Refer to paragraph 3-40. |
| | Step 2. | Check piston pin retainer for looseness. Replace the piston pin retainer and defective parts. Refer to paragraph 3-40. |
| | Step 3. | Check for scored liners, pistons or oil rings. Remove and replace the defective parts. Refer to paragraph 3-40. |
| | Step 4. | Check piston and rod alignment. Check the crankshaft thrust washers for wear. Replace worn and defective parts. Refer to paragraph 3-40. |
| | Step 5. | Check for excessive oil in crankcase. Fill the crankcase to the proper level only. |

Table 3-6. Propulsion Engine - Excessive Crankcase Pressure
 Troubleshooting.

| MALFUNCTION | TEST OR INSPECTION | CORRECTIVE ACTION |
|-------------|--------------------|-------------------|
|-------------|--------------------|-------------------|

1. Cylinder blow-by.

Step 1. Check cylinder head gasket for leaking.

Check the compression pressure and, if only one cylinder has low compression, remove the cylinder head and replace the head gaskets. Refer to paragraph 3-34.

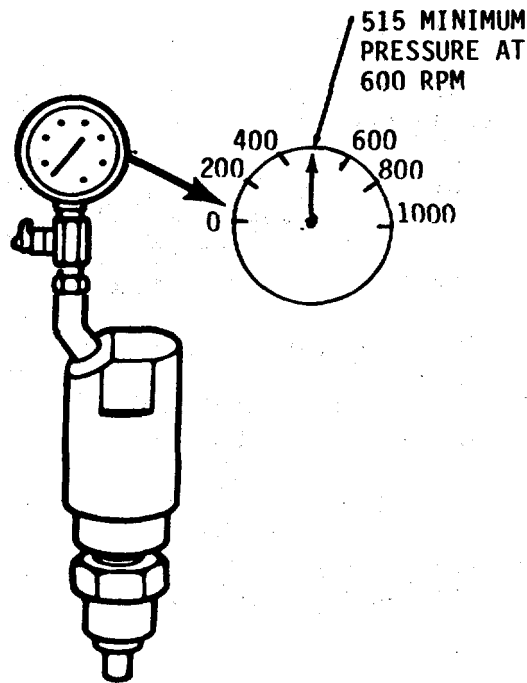

Step 2. Check for piston or liner damage.

Inspect the piston and liner and replace damaged parts. Refer to paragraph 3-40.

Step 3. Check for piston rings that are worn or broken.

Install new piston rings. Refer to paragraph 3-40.

Table 3-6. Propulsion Engine - Excessive Crankcase Pressure
 Troubleshooting (Cont).

| MALFUNCTION | TEST OR INSPECTION | CORRECTIVE ACTION |
|-------------|--------------------|-------------------|
|-------------|--------------------|-------------------|

2. Breather restriction.

- Step 1. Check for obstruction or damage to breather.
 Clean and repair or replace the breather assembly.
 Refer to paragraph 3-32.

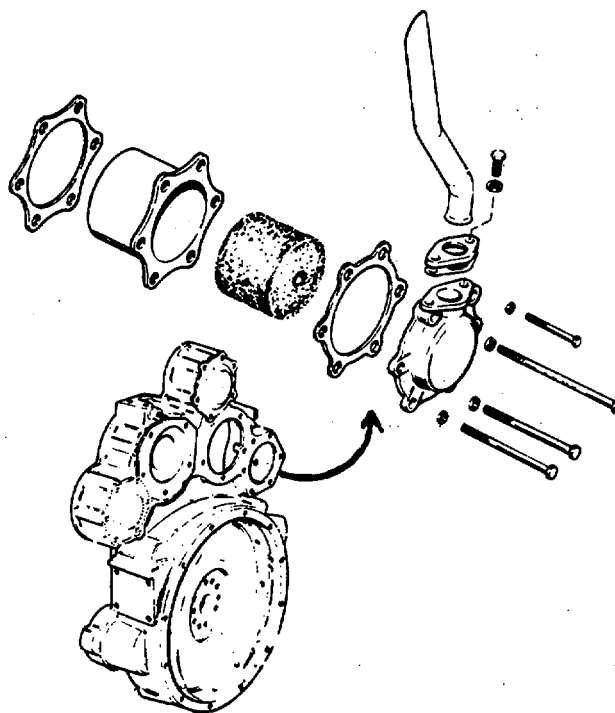

3. Air from blower or air box.

- Step 1. Check for damaged blower-to-block gasket.
 Replace the blower-to-block gasket. Refer to paragraph 3-12.
- Step 2. Check cylinder block end plate gasket for leaking.
 Replace the end plate gasket. Refer to paragraph 3-44.

Table 3-6. Propulsion Engine - Excessive Crankcase Pressure
 Troubleshooting (Cont).

| MALFUNCTION | TEST OR INSPECTION | CORRECTIVE ACTION |
|-------------------------------------|--|-------------------|
| 4. Excessive exhaust back pressure. | Step 1. Check for excessive muffler resistance. Check the exhaust back pressure and repair or replace the muffler if an obstruction is found. Refer to Direct Support Maintenance. | |
| | Step 2. Check for faulty exhaust piping. Check the exhaust back pressure. Refer to Direct Support Maintenance. | |

Table 3-7. Propulsion Engine - Low Oil Pressure Troubleshooting.

| MALFUNCTION | TEST OR INSPECTION | CORRECTIVE ACTION |
|---------------------|--|--|
| NOTE | | |
| | o | Make checks with minimum water outlet temperature of 160° F (71° C). |
| | o | An alarm will sound in the pilot house. |
| 1. Lubricating oil. | Step 1. Check for suction loss. Check the oil and bring it to the proper level on the dipstick. | |
| | Step 2. Check lubricating oil viscosity. Use the recommended grade and viscosity of oil. | |

Table 3-7. Propulsion Engine - Low Oil Pressure Troubleshooting.

(Cont).

| MALFUNCTION | TEST OR INSPECTION | CORRECTIVE ACTION |
|-------------|--------------------|-------------------|
|-------------|--------------------|-------------------|

LUBRICATING OIL GRADES

| DESCRIPTION | SPECIFICATION |
|--|---|
| OES (Sub Zero) OE/HDO - 10 OE/HDO - 20 OE/HDO - 30 | MIL - L - 10295 MIL - L - 2104 MIL - L - 2104 MIL - L - 2104 |

Check for fuel leaks at the injector nut seal ring and fuel pipe connections. Leaks at these points will cause lubricating oil dilution. Refer to paragraph 3-15.

2. Poor circulation.

Step 1. Check cooler for clogging.

A plugged oil cooler is indicated by excessively high lubricating oil temperature. Remove, and clean the oil cooler core. Refer to paragraph 3-17.

Step 2. Check for cooler by-pass valve not functioning properly.

Remove the by-pass valve. Clean the valve and valve seat and inspect the valve spring. Refer to paragraph 3-36.

Step 3. Check for pressure regulator valve that is not functioning properly.

Remove the pressure regulator valve. Clean the valve and valve seat and inspect the valve spring. Refer to paragraph 3-36.

Step 4. Check for excessive wear on crankshaft bearings.

a. Change the bearings.

Refer to paragraph 3-41.

Table 3-7. Propulsion Engine - Low Oil Pressure
Troubleshooting (Cont).

| MALFUNCTION | TEST OR INSPECTION | CORRECTIVE ACTION |
|------------------------------------|--------------------|--|
| 2. Poor circulation (Cont). | Step 4. | b. Refer to Lubrication Oil Grades Table for the proper grade and viscosity of oil. c. Change the oil filters. Refer to paragraph 3-16. |
| | Step 5. | Check for gallery, crankshaft or camshaft plugs missing. Replace missing plugs. Refer to paragraph 3-32. |
| 3. Pressure gage and alarm switch. | Step 1. | Check for faulty gage. Check the oil pressure with a reliable gage and replace the gage if found faulty. Refer to paragraph 3-24. |
| | Step 2. | Check for gage line obstruction. Remove and clean the alarm switch. Replace it, if necessary. Refer to paragraph 3-24. |
| | Step 3. | Check gage orifice plugging. Remove and clean the alarm switch. Refer to paragraph 3-24. |
| | Step 4. | Check electrical alarm panel for faults (pilot house). Repair or replace defective electrical equipment. Refer to paragraph 3-9. |
| 4. Oil pump. | Step 1. | Check intake screen for partial clogging. a. Remove and clean the oil pan and oil intake screen. Refer to paragraphs 3-35, 3-36 and 3-39. |

Table 3-7. Propulsion Engine - Low Oil Pressure
 Troubleshooting (Cont).

| MALFUNCTION | TEST OR INSPECTION | CORRECTIVE ACTION |
|---------------------|--------------------|---|
| 4. Oil pump (Cont). | | |
| | Step 1. | b. Consult the Lubricating Oil Grades Table for the proper grade and viscosity of oil. c. Change the oil filters. Refer to paragraph 3-16. |
| | Step 2. | Check for faulty relief valve. Remove and inspect the valve, valve bore and spring. Refer to paragraph 3-36. |
| | Step 3. | Check for air leak in pump suction. Disassemble the piping and install new gaskets. Refer to paragraph 3-38. |
| | Step 4. | Check pump for wear or damage. Remove the pump. Refer to paragraph 3-38. |
| | Step 5. | Check for flange leak (pressure side). Remove the pump. Refer to paragraph 3-38. |

Table 3-8. Propulsion Engine - Abnormal Engine Coolant Operating
 Temperature Troubleshooting.

| MALFUNCTION | TEST OR INSPECTION | CORRECTIVE ACTION |
|------------------------------|--------------------|-------------------|
| 1. Temperature above normal. | | |

NOTE

An alarm will sound in the pilot house.

Table 3-8. Propulsion Engine - Abnormal Engine Coolant Operating Temperature Troubleshooting.

| MALFUNCTION | TEST OR INSPECTION | CORRECTIVE ACTION |
|-------------------------------------|--------------------|---|
| 1. Temperature above normal (Cont). | Step 1. | <p>Check for insufficient heat transfer.</p> <p>Clean the cooling system with a good cooling system cleaner and thoroughly flush to remove scale deposits.</p> |
| | Step 2. | <p>Check for poor circulation.</p> <p>a. Check the coolant level and fill to the filler neck if the coolant level is low.</p> <p>b. Inspect for collapsed or disintegrated hoses.</p> <p>Replace faulty hoses. Refer to paragraph 3-20.</p> <p>c. Thermostat may be inoperative. Remove, inspect and test the thermostat; replace if found faulty. Refer to paragraph 3-22.</p> <p>d. Check the water pump for a loose or damaged impeller.</p> <p>Refer to paragraph 3-18.</p> <p>e. Check the flow of coolant through the expansion tank and keel coolers. A clogged expansion tank or keel cooler will cause an inadequate supply of coolant on the suction side of the pump. Clean the expansion tank, and keel coolers. Refer to paragraph 3-19 and Direct Support Maintenance.</p> <p>Remove the coolant filler cap and operate the engine, checking for combustion gases in the cooling system. The cylinder head must be removed and inspected for cracks and the head gaskets replaced if combustion gases are entering the cooling system. Refer to paragraph 3-34.</p> <p>Check for an air leak on the suction side of the water pump. Replace defective parts. Refer to paragraph 3-18.</p> |

Table 3-8. Propulsion Engine - Abnormal Engine Coolant Operating
Temperature Troubleshooting (Cont).

| MALFUNCTION | TEST OR INSPECTION | CORRECTIVE ACTION |
|------------------------------|---|--|
| 2. Temperature below normal. | Step 1. Check for improper circulation. | The thermostat may not be closing. Remove, inspect and test the thermostat. Install a new thermostat, if necessary. Refer to paragraph 3-22. |
| | Step 2. Check for excessive leakage at thermostat seal. | Excessive leakage of coolant past the thermostat seal(s) is a cause of continued low coolant operating temperature. When this occurs, replace the thermostat seal(s). Refer to paragraph 3-22. |

Table 3-9. Propulsion Engine - Low or High Exhaust Valve Opening
Pressure Troubleshooting.

| MALFUNCTION | TEST OR INSPECTION | CORRECTIVE ACTION |
|--|--|---|
| 1. Low exhaust valve opening pressure. | Step 1. Check for worn or eroded valve seat. | Replace worn or eroded valve seat. Refer to paragraph 3-34. |
| | Step'2. Check valve seat for chips at point of contact with valve. | Replace the valve seat. Refer to paragraph 3-34. |
| | Step 3. Check for cracked valve seat. | Replace the valve seat. Refer to paragraph 3-34. |

Table 3-9. Propulsion Engine - Low or High Exhaust Valve Opening
Pressure Troubleshooting (Cont)

| MALFUNCTION | TEST OR INSPECTION | CORRECTIVE ACTION |
|--|---|--|
| 1. Low exhaust valve opening pressure (Cont) | Step 4. Check for worn valve or valve locks. | Replace the valve or valve lock. Refer to paragraph 3-33. |
| | Step 5. Check for worn or broken valve spring. | Replace the spring. Check the valve cage and valve stop for wear; replace them if necessary. Refer to paragraph 3-33. |
| | Step 6. Check for dirt or foreign material in injector. | Replace the injector. Refer to paragraph 3-15. |
| | Step 7. Check for worn valve spring stop seat. | Replace the valve spring stop seat. Refer to paragraph 3-34. |
| 2. High valve opening pressure. | Step 1. Check for carbon or foreign material in injector spray tip. | Replace injector. Refer to paragraph 3-15. |

Table 3-10. Marine Gear Troubleshooting.

NOTE

Refer to paragraph 3-8 for all Marine Gear Maintenance unless otherwise specified.

MALFUNCTION
TEST OR INSPECTION**CORRECTIVE ACTION**

1. Low oil pressure.

Step 1. Check for partially clogged oil strainer.

Remove and clean oil strainer.

Step 2. Check for stuck pressure regulation piston in selector valve assembly.

Remove selector valve assembly. Disassemble the valve, and clean the piston.

Step 3. Check for broken piston rings in clutches.

Refer to Direct Support Maintenance.

Step 4. Check for come-home setscrew loose or missing.

Refer to Direct Support Maintenance.

Step 5. Check for damaged or worn oil pump assembly.

Remove oil pump assembly and replace if worn or damaged.

Step 6. Check for incorrect linkage installation on selector valve assembly.

Adjust linkage so that selector valve stem is indexed properly by detent pin.

Step 7. Check for clogged or plugged orifice in the orifice plate or the selector valve assembly.

Remove orifice plate cover. Clean parts.

Table 3-10. Marine Gear Troubleshooting (Cont).

| MALFUNCTION | TEST OR INSPECTION | CORRECTIVE ACTION |
|-----------------------|--------------------|--|
| 2. No oil pressure. | Step 1. | Check for low oil level or empty sump. Check gaskets and seals for leakage. Replace parts causing leakage. Fill marine gear. |
| | Step 2. | Check for fully clogged oil strainer. Remove and clean oil strainer. |
| | Step 3. | Check for damaged or worn oil pump assembly. Remove oil pump assembly. Replace damaged or worn oil pump assembly. |
| 3. High oil pressure. | Step 1. | Check for stuck pressure regulation piston in selector valve assembly. Remove selector valve assembly. Disassemble the valve, and clean the piston. |
| 4. Overheating. | Step 1. | Check for insufficient heat exchanger capacity. Refer to Table 3-8. |
| | Step 2. | Check for clutch slippage. Low oil pressure will cause a clutch to slip. Refer to MALFUNCTION 1. |
| | Step 3. | Check for oil level that is too high. Correct oil level. |
| | Step 4. | Check for improper oil in sump. Drain marine gear, and fill with proper oil. |
| | Step 5. | Check for warped clutch plates. Refer to Direct Support Maintenance. |

Table 3-10. Marine Gear Troubleshooting (Cont).

| MALFUNCTION | TEST OR INSPECTION | CORRECTIVE ACTION |
|--------------------------|--------------------|---|
| 4. Overheating (Cont). | Step 6. | Check for bearing failure. Refer to Direct Support Maintenance. |
| 5. Reduced oil pressure. | Step 1. | Check for clogged oil filter element. Fully clogged oil filter element will drop oil pressure approximately 10-15 psi (68.95 to 103.43 kPa) from normal reading. Replace oil filter element. |
| | Step 2. | Check for broken piston rings on clutch shaft. Refer to Direct Support Maintenance. |
| 6. Excessive noise. | Step 1. | Check for air leak in oil-sump-to-strainer flexible hose or oil strainer housing. Tighten all fittings. Replace a damaged hose. |
| | Step 2. | Check for bearing failure. Refer to Direct Support Maintenance. |
| | Step 3. | Check for worn or damaged rubber blocks. Refer to Direct Support Maintenance. |
| | Step 4. | Check for broken or chipped gear teeth. Refer to Direct Support Maintenance. |
| 7. No neutral. | Step 1. | Check for warped clutch plates. Refer to Direct Support Maintenance. |

Table 3-10. Marine Gear Troubleshooting (Cont).

| MALFUNCTION | TEST OR INSPECTION | CORRECTIVE ACTION |
|-------------|--------------------|-------------------|
| | | |

8. Harsh engagement.

Step 1. Check for steel ball in selector valve not seating properly.

Remove orifice cover. Clean parts. Replace parts if necessary.

Table 3-11. Hydrostarter - Low or No Accumulator Pressure

Troubleshooting.

| MALFUNCTION | TEST OR INSPECTION | CORRECTIVE ACTION |
|-------------|--------------------|-------------------|
|-------------|--------------------|-------------------|

1. Engine driven pump fails to raise pressure:

Step 1. Check for air in system.

To purge the engine driven pump of air:

- a. Operate the engine at maximum no-load engine speed.
- b. Break the hose connection (1) on the pressure side of the engine-driven pump until a full stream of oil is discharged from the pump.
- c. Connect the hose to the pump and alternately loosen and tighten the swivel fitting (2) on the pressure hose until the oil leaking out when the fitting is loose appears free of air bubbles.
- d. Tighten the swivel fitting securely and observe the pressure gage. The pressure must rise rapidly to the accumulator precharge pressure (1250 psi at 70°F)(8274 kPa at 68.4°C). Then the pressure must increase slowly to 2900 to 3300 psi (19996 to 22754 kPa) in 6 to 10 minutes, depending upon the size of the particular accumulator.

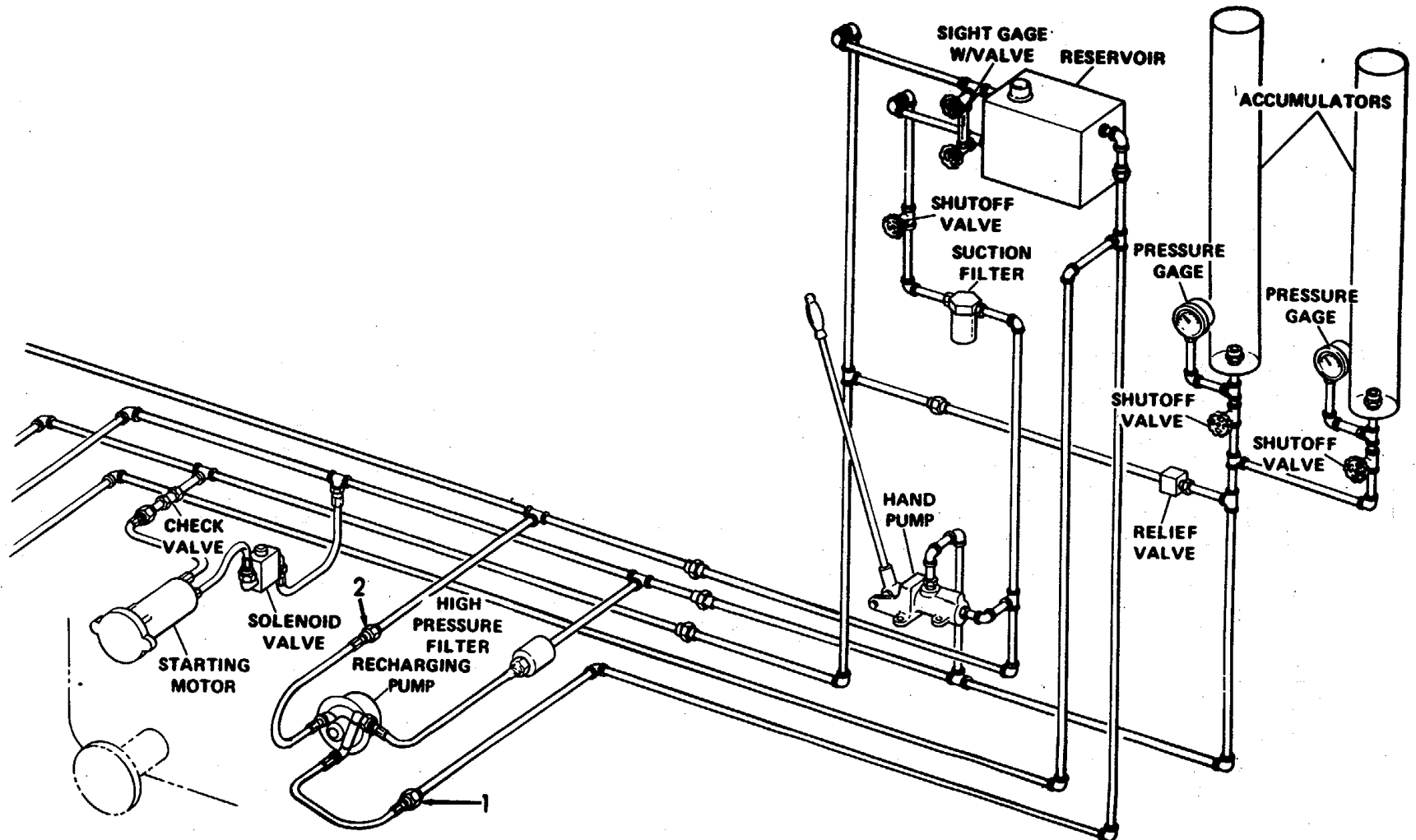

MAIN PROPULSION ENGINE CONNECTIONS

MAIN PROPULSION ENGINE CONNECTIONS

Table 3-11. Hydrostarter - Low or No Accumulator Pressure Troubleshooting (Cont).

| MALFUNCTION | TEST OR INSPECTION | CORRECTIVE ACTION |
|---|--------------------|--|
| 1. Engine driven pump fails to raise pressure (Cont). | e. | If the accumulator pressure does not rise, make certain that the hand pump relief valve (3) is closed after the pressure is released and repeat the above purging procedure. |

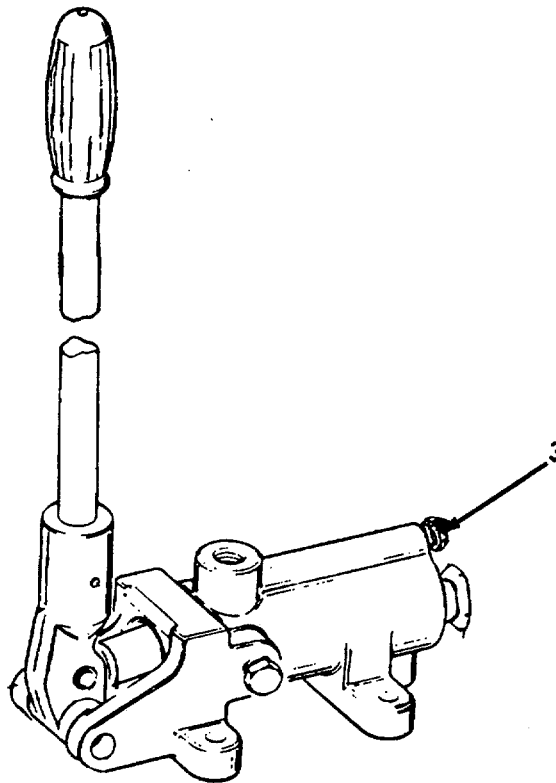

Table 3-11. Hydrostarter - Low or No Accumulator Pressure Troubleshooting (Cont).

| MALFUNCTION | TEST OR INSPECTION | CORRECTIVE ACTION |
|-------------|--------------------|-------------------|
|-------------|--------------------|-------------------|

1. Engine driven pump fails to raise pressure (Cont).

Step 2. Check for low fluid level.

The fluid level in the reservoir must be sufficient to completely cover the screen at the bottom of the tank after the accumulator is charged and the engine-driven pump is by-passing a full stream of fluid to the reservoir.

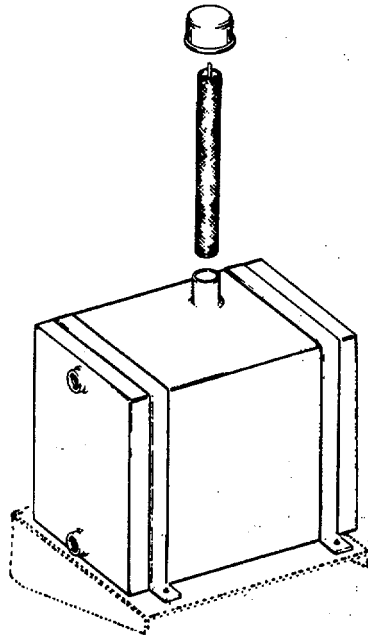

Table 3-11. Hydrostarter - Low or No Accumulator Pressure Troubleshooting (Cont).

| MALFUNCTION | TEST OR INSPECTION | CORRECTIVE ACTION |
|-------------|---|---|
| 1. | Engine driven pump fails to raise pressure (Cont) Step 3. Check for plugged screen or filter. | |
| | a. | Remove and clean the reservoir screen and flush out the reservoir tank. Refer to paragraph 3-52. |
| | b. | Clean the filter located in the supply hose between the reservoir and the engine-driven pump. Refer to paragraph 3-52. |
| | Step 4. | Check for check valves not functioning properly. |
| | a. | Open the relief valve (3) on the side of the hand pump, while the engine is running to permit the engine-driven pump to wash the check valves free from particles. |
| | b. | If the accumulator can be charged with the hand pump but not with the engine-driven pump, then a check valve in the engine pump is defective. Replace the faulty check valve assembly. Refer to paragraph 3-48. |
| | Step 5. | Check for defective drive. |
| | | Replace the pump drive arm. Refer to paragraph 3-48. |

Table 3-12. Hydrostarter - Cranking Speed Too Low Troubleshooting.

| MALFUNCTION | TEST OR INSPECTION | CORRECTIVE ACTION |
|-------------|--------------------|-------------------|
|-------------|--------------------|-------------------|

1. Cranking speed to low.

Step 1. Check that hydrostarter system fluid is not too heavy.
 Check the fluid in the system. Use Hydraulic Fluid MIL-L-17672 type 2135 TH.

Step 2. Check that engine oil is not too heavy.
 Replace the oil with the proper viscosity grade.

LUBRICATING OIL GRADES

| DESCRIPTION | SPECIFICATION |
|----------------|---------------|
| OES (Sub Zero) | MIL-L-10295 |
| OE/HDO - 10 | MIL-L-2104 |
| OE/HDO - 20 | MIL-L-2104 |
| OE/HDO - 30 | MIL-L-2104 |

Step 3. Check for control valve that is not fully open.
 Valve body sticking in valve housing. Replace valve cage and valve assembly.

Step 4. Check for inlet line restricted.
 Check plumbing from accumulator to hydrostarter to insure hoses are not collapsed and are free of obstructions.

Step 5. Check for excessive internal leakage in hydrostarter.
 Examine around hydrostarter for broken thrust bearing plate, scored port plate, frozen piston or broken cylinder spring.

Table 3-13. Hydrostarter - Loss of Fluid from Reservoir Troubleshooting.

| MALFUNCTION | TEST OR INSPECTION | CORRECTIVE ACTION |
|----------------------------------|---|---|
| 1. Loss of fluid from reservoir. | Step 1. Inspect for external leaks. | With pressure in the system, check all hoses and fittings for leaks. Tighten the fittings. Refer to Direct Support Maintenance. |
| | Step 2. Inspect hydrostarter shaft seal for leaking. | Remove hydrostarter inspection cover and look for signs of hydraulic oil on the Bendix drive, the Hydrostarter shaft and inside the pinion gear housing. Refer to Direct Support Maintenance. |
| | Step 3. Inspect engine pump shaft seal for leaking. | Refer to Direct Support Maintenance. |
| | Step 4. Inspect, hand pump seal for leaking. | Remove plunger gland and replace inner and outer O-rings. |
| Table 3-14. | Hydrostarter - Loss of Fluid Pressure When Engine is Not Running - Troubleshooting. | |

| MALFUNCTION | TEST OR INSPECTION | CORRECTIVE ACTION |
|---|---|---|
| 1. Loss of fluid pressure when engine is not running. | Step 1. Check for ambient temperature decrease. | A drop in temperature will decrease the nitrogen pressure. Adjust the pressure as needed for cranking requirements by use of the hand pump. |

Table 3-14. Hydrostarter - Loss of Fluid Pressure When Engine is Not Running Troubleshooting (Cont).

| MALFUNCTION | TEST OR INSPECTION | CORRECTIVE ACTION |
|--|--------------------|--|
| 1. Loss of fluid pressure when engine is not running (Cont). | Step 2. | Check for engine driven pump check valves not holding. Disconnect the return hose and inlet hose from the engine-driven pump. Leakage from the inlet fitting means that both check valves are defective. Leakage at the return fitting means that only out- let check valve is defective. Replace the defective check valve assembly(s). Refer to paragraph 3-48. |
| | Step 3. | Check for hand pump valves not holding. Disconnect the inlet hose from the hand pump. Leakage from the inlet fitting means that either the relief valve alone or both the inlet and outlet check valves are defective. Stone and clean the ball seats in the pump body and replace the balls and springs if necessary. Refer to paragraph 3-49. |
| | Step 4. | Check for damaged seal ring in starter control valve shown by external leakage. Refer to Direct Support Maintenance. |
| | Step 5. | Check for external leakage in system. Examine all hoses and fittings for leaks. Tighten. Refer to Direct Support Maintenance. |
| | Step 6. | Check for loss of accumulator precharge (nitrogen). See table 3-17. |

Table 3-15. Hydrostarter - Hand Pump Fails to Discharge Fluid Troubleshooting.

| MALFUNCTION | TEST OR INSPECTION | CORRECTIVE ACTION |
|-------------|--------------------|-------------------|
|-------------|--------------------|-------------------|

1. Hand pump fails to discharge fluid.
 - Step 1. Check for open manual relief valve.
Close the relief valve.

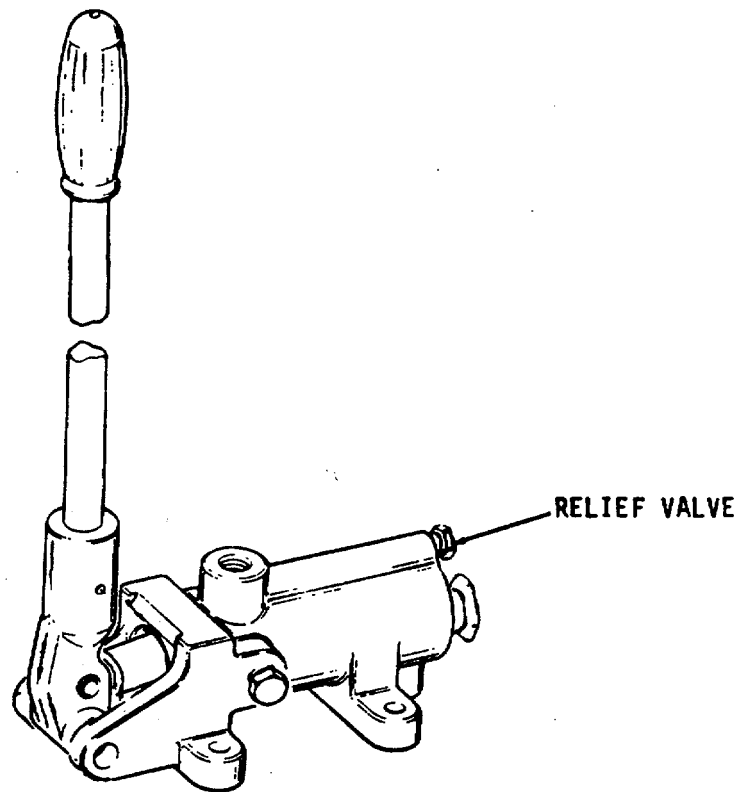

Table 3-15. Hydrostarter - Hand Pump Fails to Discharge Fluid Troubleshooting (Cont).

| MALFUNCTION | TEST OR INSPECTION | CORRECTIVE ACTION |
|---|--------------------|---|
| 1. Hand pump fails to discharge fluid (Cont). | Step 2. | Check for leaking check valves. Hand pump handle will not stay in neutral position but will move to one end of the stroke. If caused by dirt, open the relief valve and operate the hand pump slowly for a few minutes to wash the particles out of the check valves. If this is unsuccessful, stone and clean the ball seats in the pump body and replace the balls and springs if necessary. Refer to paragraph 3-49. |
| | Step 3. | Check for plugged reservoir screen. Remove and clean the reservoir screen, flush the reservoir tank and reassemble. Refer to Direct Support Maintenance. |
| | Step 4. | Check for low fluid level. See table 3-11, step 2. |
| | Step 5. | Check for air in system. |
| | | To purge the hand pump of air: |
| | a. | Relieve any system pressure, then disconnect the outlet hose from the hand pump. |
| | b. | Close the manual relief valve and operate the pump until fluid is-discharged when stroking in both directions. |
| | c. | Reconnect the outlet hose. |
| | Step 6. | Check for dirt in pump. |
| | | See step 2. |
| | Step 7. | Check for damaged piston seal rings. |
| | | Replace the seal rings. Refer to paragraph 3-49. |

Table 3-16. Hydrostarter - Starter Turns but Engine Does Not.
Troubleshooting.

| MALFUNCTION | TEST OR INSPECTION | CORRECTIVE ACTION |
|---------------------------------------|---|--|
| 1. Starter turns but engine does not. | Step 1. Check for pinion not engaging flywheel ring gear. | Replace as per paragraph 3-46. Refer to Direct Support Maintenance. |
| | Step 2. Check for broken bendix drive. | Replace Bendix drive. Operator should disengage hydrostarter as soon as engine starts. Prolonging the period during which clutch overruns will reduce clutch life. |

Table 3-17. Hydrostarter - Loss of Accumulator Precharge (Nitrogen) Troubleshooting

| MALFUNCTION | TEST OR INSPECTION | CORRECTIVE ACTION |
|---|--|---|
| 1. Loss of accumulator precharge (nitrogen) | Step 1. Check for damaged seal ring on piston. | With some nitrogen precharge but no fluid pressure in the system, bubbles and foaming in the reservoir indicate that the nitrogen is leaking past the seal ring on the accumulator piston. Refer to Direct Support Maintenance. |

Table 3-17. Hydrostarter - Loss of Accumulator Precharge (Nitrogen) Troubleshooting (Cont).

MALFUNCTION

TEST OR INSPECTION

CORRECTIVE ACTION

1. Loss of accumulator precharge (nitrogen) (Cont).

Step 2. Check for defective air valve.

Release the pressure in the system by opening the relief valve on the side of the hand pump. Then, loosen the hex lock nut on the nitrogen valve approximately 3/4 turn to release the remaining precharge before attempting to remove the valve from the accumulator. Replace the air valve. Refer to Direct Support Maintenance.

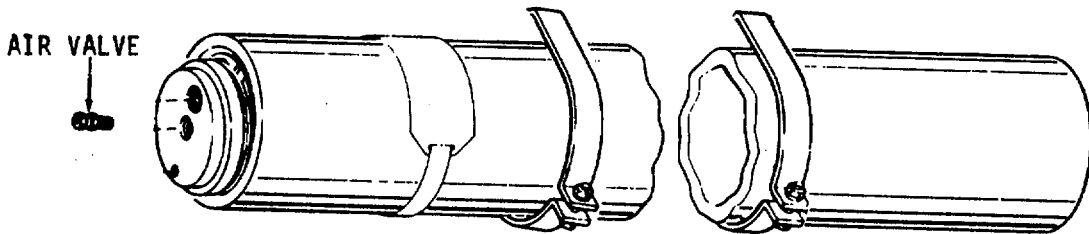

Step 3. Check for damaged seal ring between shell and end cap.

Apply light oil on the threaded end of the accumulator at the end of the cap. Bubbling of the oil indicates a leak past the end cap seal. Refer to Direct Support Maintenance.

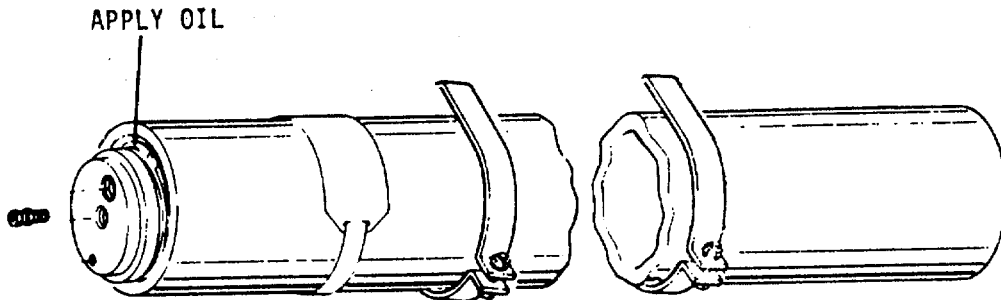

Table 3-17. Hydrostarter - Loss of Accumulator Precharge (Nitrogen) Troubleshooting (Cont).

| MALFUNCTION | TEST OR INSPECTION | CORRECTIVE ACTION |
|---|--|--|
| 1. Loss of accumulator precharge (nitrogen) (Cont). | Step 4. Check for defective safety fuse. | Replace safety fuse assembly after releasing all nitrogen pressure. Refer to Direct Support Maintenance. |

Table 3-18. Hydrostarter - High Pressure in System (3500 psi or above) Troubleshooting.

| MALFUNCTION | TEST OR INSPECTION | CORRECTIVE ACTION |
|---|--|--------------------------------------|
| 1. High pressure in system - 3500 psi (24133 kPa) or above. | Step 1. Check for defective gage. | Refer to Direct Support Maintenance. |
| | Step 2. Check for engine driven pump unloading valve not operating properly. | Refer to Direct Support Maintenance. |

Table 3-19. Hydrostarter - Fluid Emerges from the Reservoir Filler Cap When Starter is Used - Troubleshooting.

| MALFUNCTION | TEST OR INSPECTION | CORRECTIVE ACTION |
|--|--|---|
| 1. Fluid emerges from the reservoir filler cap when starter is used. | <p>Step 1. Check for filter element in filler cap loaded with dirt.</p> <p>Rinse the filler cap thoroughly in fuel oil and dry it with compressed air.</p> <p>Step 2. Check for nitrogen in fluid returned to reservoir. Overhaul the accumulator. See table 3-17.</p> <p>Step 3. Check for excess fluid in reservoir.</p> | <p>Check the fluid level when the accumulator is empty. The fluid level should be approximately 2-1/2 inches (6.4 cm) from the top of the tank.</p> |

Table 3-20. Hydrostarter - Fluid Emerges Around Rubber Boot of Hand Pump - Troubleshooting.

| MALFUNCTION | TEST OR INSPECTION | CORRECTIVE ACTION |
|---|---|--|
| 1. Fluid emerges around rubber boot of hand pump. | <p>Step 1. Check for damaged piston seal rings.</p> | <p>Replace the seal rings and leather back-up rings on the pump piston. Refer to paragraph 3-49.</p> |

Table 3-21. Hydrostarter - Cranking Cycle Too Short Troubleshooting.

| MALFUNCTION | TEST OR INSPECTION | CORRECTIVE ACTION |
|---------------------------------|---|---|
| 1. Cranking cycle is too short. | Step 1. Check for faulty pressure gage. | If gage is reading higher than actual system pressure, oil volume in the accumulator will be less. Replace gage. |
| | Step 2. Check for excessive internal leakage in hydrostarter. | Refer to table 3-12. |
| | Step 3. Check for accumulator precharge too high. | With the fuel shut off to prevent engine from starting, crank the engine until all oil is used. If the gage then registers zero pressure, install a gaging assembly on the air valve and drop the precharge to 1250 psi (1695 kPa). Repeat cranking cycle. If gage will still drop to zero at end of cranking cycle, reduce precharge to 1000 psi (1356 kPa). |
| | Step 4. Check for accumulator precharge too low. | Open the bypass valve on the hand pump to discharge oil from the accumulator. Install a gaging assembly on the accumulator 'air valve. If pre-charge is less than 1500 psi (2034 kPa), add nitrogen. Make sure precharge holds by testing for nitrogen leakage. Refer to table 3-17. |

Table 3-22. Generator Engine - Exhaust Smoke Analysis Troubleshooting.

| MALFUNCTION | TEST OR INSPECTION | CORRECTIVE ACTION |
|-------------|--------------------|-------------------|
|-------------|--------------------|-------------------|

1. Black or grey smoke observed.

Step 1. Check for high exhaust back pressure which is caused by faulty exhaust piping or muffler obstruction.

Refer to Direct Support Maintenance.

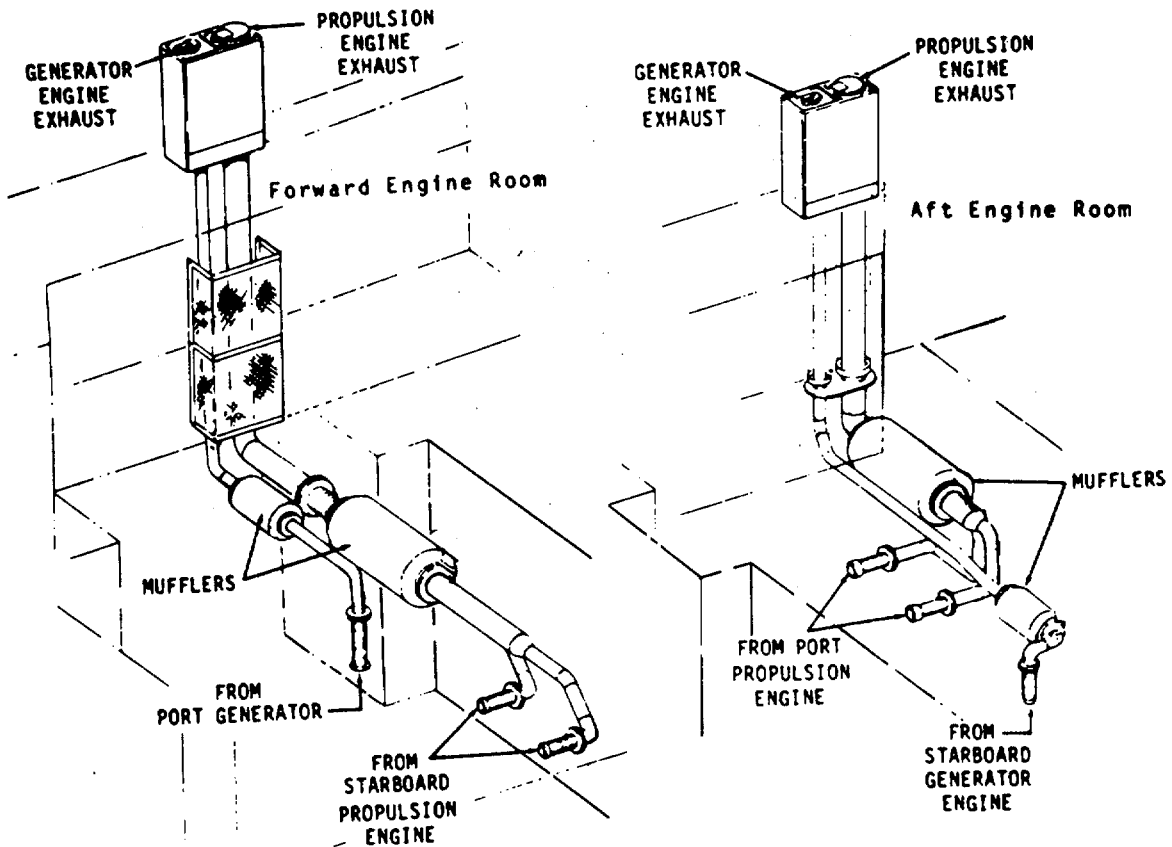

Table 3-22. Generator Engine - Exhaust Smoke Analysis Troubleshooting (Cont)

| MALFUNCTION | TEST OR INSPECTION | CORRECTIVE ACTION |
|-------------|--------------------|-------------------|
|-------------|--------------------|-------------------|

1. Black or grey smoke observed (Cont)
 - Step 2. Check for restricted air inlet to the engine cylinders.
Remove air box covers. Clean ports in cylinder liner. Refer to paragraph 3-98.
 - Step 3. Check air cleaner and blower air inlet screen. Clean. Refer to paragraph 3-61 and 3-75.

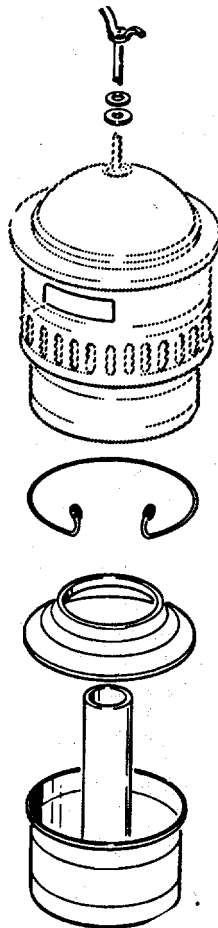

Table 3-22. Generator Engine - Exhaust Smoke Analysis Troubleshooting (Cont).

| MALFUNCTION | TEST OR INSPECTION | CORRECTIVE ACTION |
|-------------|--------------------|-------------------|
|-------------|--------------------|-------------------|

1. Black or grey smoke observed (Cont).

Step 4. Check the emergency stop to make sure that it is completely open. Readjust if necessary.

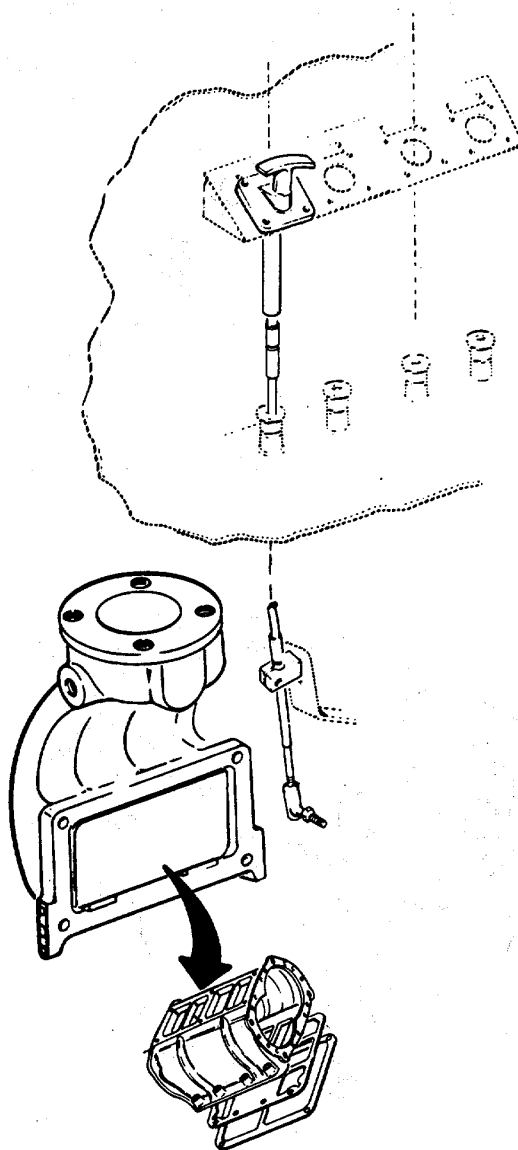

Table 3-22. Generator Engine - Exhaust Smoke Analysis Troubleshooting (Cont).

| MALFUNCTION | TEST OR INSPECTION | CORRECTIVE ACTION |
|-------------|--------------------|-------------------|
|-------------|--------------------|-------------------|

- | | | |
|----|--|---|
| 2. | Black or gray smoke caused by -excessive fuel or irregular fuel distribution. | |
| | Step 1. Check for improperly timed injectors and improperly positioned injector rack control levers. | |
| | | Time the fuel injectors. Refer to paragraph 3-87. |

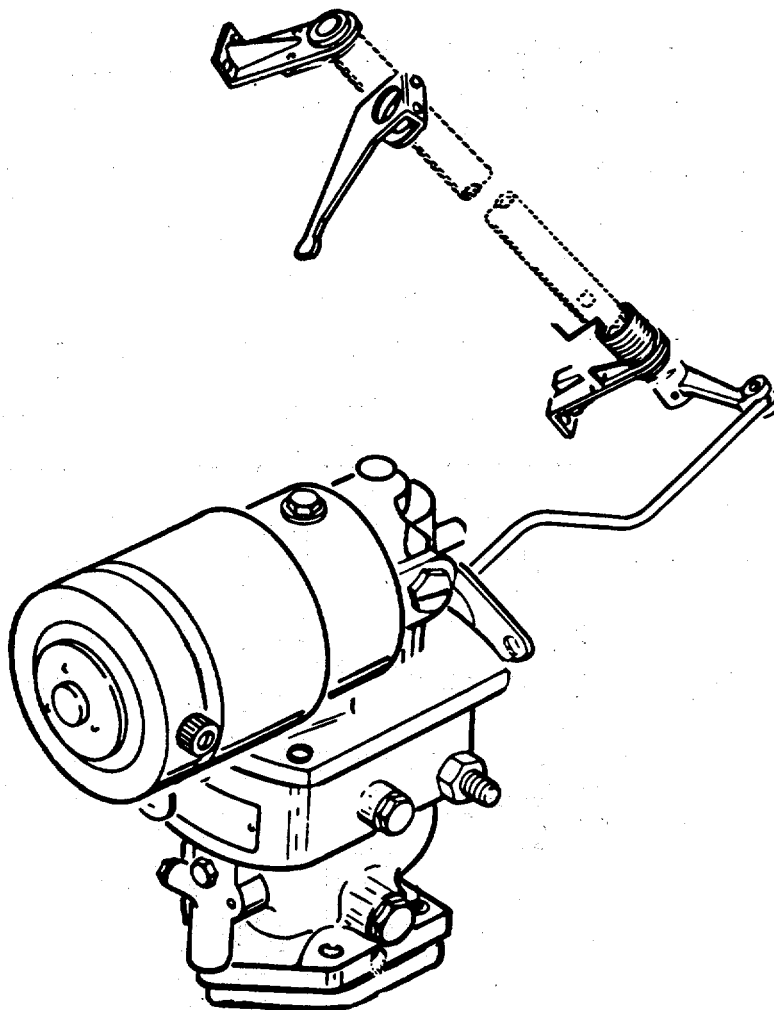

Table 3-22. Generator Engine - Exhaust Analysis Troubleshooting (Cont).

| MALFUNCTION | TEST OR INSPECTION | CORRECTIVE ACTION |
|-------------|--------------------|-------------------|
|-------------|--------------------|-------------------|

2. Black or gray smoke caused by excessive fuel or irregular fuel distribution (Cont).

Step 2. If this condition still persists after timing the injectors.

Replace faulty injectors. Refer to paragraph 3-71.

NOTE

Avoid lugging the engine as this will cause incomplete combustion. If problem remains, refer to Direct Support Maintenance.

3. Black or gray smoke caused by improper grade of fuel.

Check for use of an improper grade of fuel.

DIESEL FUEL

| TYPE | NATIONAL STOCK NUMBER |
|----------------|-----------------------|
| ARTIC (DF-A) | 9140-00-286-5283 |
| WINTER (DF-W) | 9140-00-286-5286 |
| REGULAR (DF-2) | 9140-00-286-5294 |

4. Blue smoke.

Check for internal lubricating oil leaks. Lubricating oil not burned in cylinder (blown through cylinder during scavenging period).

Refer to the High Lubricating Oil Consumption Table 3-26.

Table 3-22. Generator Engine - Exhaust Analysis Troubleshooting (Cont).

| MALFUNCTION | TEST OR INSPECTION | CORRECTIVE ACTION |
|-----------------|--|-------------------|
| 5. White smoke. | <p>Check for faulty injectors and replace as necessary.</p> <p>Refer to paragraph 3-71.</p> <p>Check for low compression.</p> <p>Consult the Hard Starting Table 3-23.</p> | |

Table 3-23. Generator Engine - Hard Starting - Troubleshooting.

| MALFUNCTION | TEST OR INSPECTION | CORRECTIVE ACTION |
|----------------------------|--|-------------------|
| 1. Engine will not rotate. | <p>Step 1. Check hydrostarter.</p> <p>Refer to tables 3-11 through 3-21, and perform the operations listed.</p> <p>Step 2. Check for defective starting motor switch in either the engine access room or engine room.</p> <p>Replace the starting motor switch in the engine room. Refer to paragraph 3-99. Refer to Direct Support Maintenance for the switch in the engine access room.</p> <p>Step 3. Check for internal seizure.</p> <p>Crank the engine at least one complete revolution. If the engine cannot be rotated a complete revolution, internal damage is indicated and the engine must be disassembled to ascertain the extent of damage and the cause. Refer to paragraph 3-64.</p> | |

Table 3-23. Generator Engine - Hard Starting - Troubleshooting.(Cont).

| MALFUNCTION | TEST OR INSPECTION | CORRECTIVE ACTION |
|-------------|--------------------|-------------------|
|-------------|--------------------|-------------------|

2. Low cranking speed.

Step 1. Check for improper lubricating oil viscosity.

Use the recommended grade of oil.

LUBRICATING OIL GRADES

| DESCRIPTION | SPECIFICATION |
|----------------|---------------|
| OES (Sub Zero) | MIL-L-10295 |
| OE/HDO - 10 | MIL-L-2104 |
| OE/HDO - 20 | MIL-L-2104 |
| OE/HDO - 30 | MIL-L-2104 |

NOTE

At low ambient temperatures, use of a starting aid will reduce the cranking time.

Step 2. Check for loose hydrostarter connections or faulty starter.

Tighten the starter connections. Refer to tables 3-14 through 3-21 for hydrostarter problems.

3. No fuel.

Step 1. Check for air leaks, flow obstruction, faulty fuel pump, and faulty installation.

To check for air leaks, flow obstruction, faulty fuel pump or faulty installation, consult the No Fuel or Insufficient Fuel Table 3-4.

Table 3-23. Generator Engine - Hard Starting Troubleshooting.(Cont).

| MALFUNCTION | TEST OR INSPECTION | CORRECTIVE ACTION |
|---------------------|---|---|
| 3. No fuel (Cont). | Step 2. Check for injector racks not in full-fuel position. | Check for bind in the governor-to-injector linkage. Readjust the governor and injector controls if necessary. Refer to paragraph 3-66 and 3-87. |
| 4. Low compression. | Step 1. Check for exhaust valves that are sticking or burned. | Remove the cylinder head and recondition the exhaust valves. Refer to paragraph 3-89. |
| | Step 2. Check for compression rings that are worn or broken. | Remove the air box covers and inspect the compression rings through the ports in the cylinder liners. Overhaul the cylinder assemblies if the rings are badly worn or broken. Refer to paragraph 3-96. |
| | Step 3. Check for cylinder head gasket leaking. | To check for compression gasket leakage, remove the coolant filler cap and operate the engine. A steady flow of gases from the coolant filler indicates either a cylinder head gasket is damaged or the cylinder head is cracked. Remove the cylinder head and replace the gaskets or cylinder head. Refer to paragraph 3-89. |

Table 3-23. Generator Engine - Hard Starting Troubleshooting.(Cont).

| MALFUNCTION | TEST OR INSPECTION | CORRECTIVE ACTION |
|-------------|--------------------|-------------------|
|-------------|--------------------|-------------------|

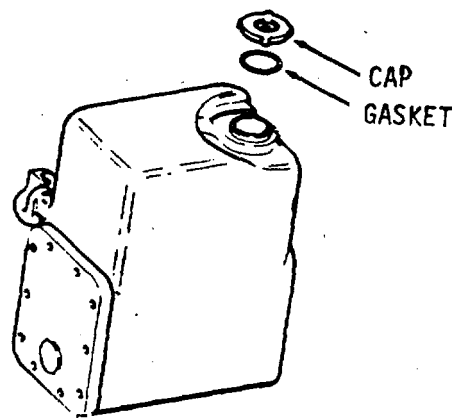

4. Low compression (Cont).

Step 4. Check for improper valve clearance adjustment.

Adjust the exhaust valve clearance. Refer to paragraph 3-90.

Step 5. Check for blower not functioning.

Inspect the blower drive shaft and drive coupling. Refer to paragraph 3-61.

5. Inoperative starting aid at low ambient temp.

Check for improper operation of fluid starting aid. Operate the starting aid. Refer to paragraph 2-39.

Table 3-24. Generator Engine - Abnormal Engine Operation Troubleshooting.

| MALFUNCTION | TEST OR INSPECTION | CORRECTIVE ACTION |
|-------------|--------------------|-------------------|
|-------------|--------------------|-------------------|

1. Uneven running or frequent stalling.

Step 1. Check for low coolant temperature.

Check the engine coolant temperature gage and, if the temperature does not reach 160 to 185 F (71 to 85 C), while the engine is operating, consult the Abnormal Engine Coolant Temperature Table 3-29.

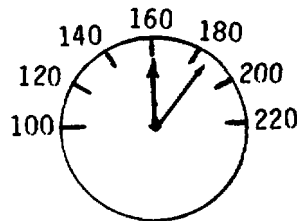

Step 2. Check for insufficient Fuel.

Check engine fuel spill back and if the return is less than 0.8 gallons per minute with the engine at 1200 RPM, consult the No Fuel or Insufficient Fuel Table 3-25.

REMOVE PLUG AND INSTALL CONNECTOR AND PIPE

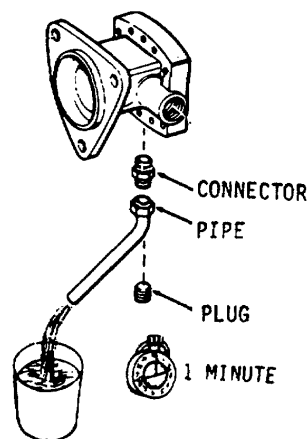

Table 3-24. Generator Engine - Abnormal Engine Operation Troubleshooting (Cont).

| MALFUNCTION | TEST OR INSPECTION | CORRECTIVE ACTION |
|-------------|--------------------|-------------------|
|-------------|--------------------|-------------------|

1. Uneven running or frequent stalling (Cont).

Step 3. Check for faulty injectors.

a. Check the injector timing and the position of the injector racks. Refer to paragraph 3-87.

b. Erratic engine operation may also be caused by leaking injector spray tips. Replace the faulty injectors.

Refer to paragraph 3-71.

Step 4. Check for low compression pressures within the cylinders.

Consult the Hard Starting Table 3-23 if compression pressures are low.

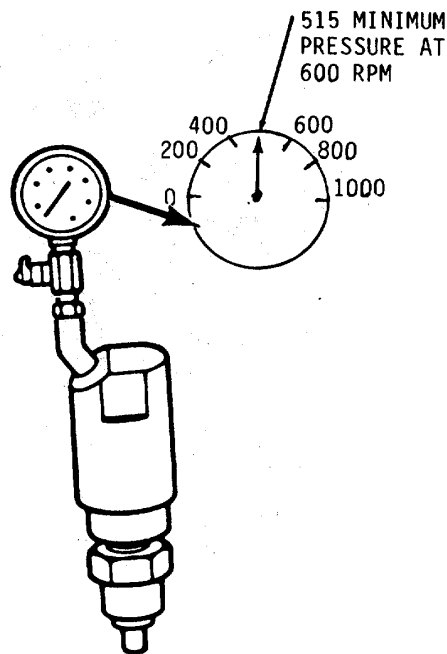

Table 3-24. Generator Engine - Abnormal Engine Operation Troubleshooting (Cont).

| MALFUNCTION | TEST OR INSPECTION | CORRECTIVE ACTION |
|-------------|--------------------|-------------------|
|-------------|--------------------|-------------------|

1 Uneven running or frequent stalling (Cont).

Step 5. Check for governor instability (hunting).

Erratic engine operation may be caused by governor-to-injector operating linkage bind or misadjusted engine. Refer to paragraph 3-64.

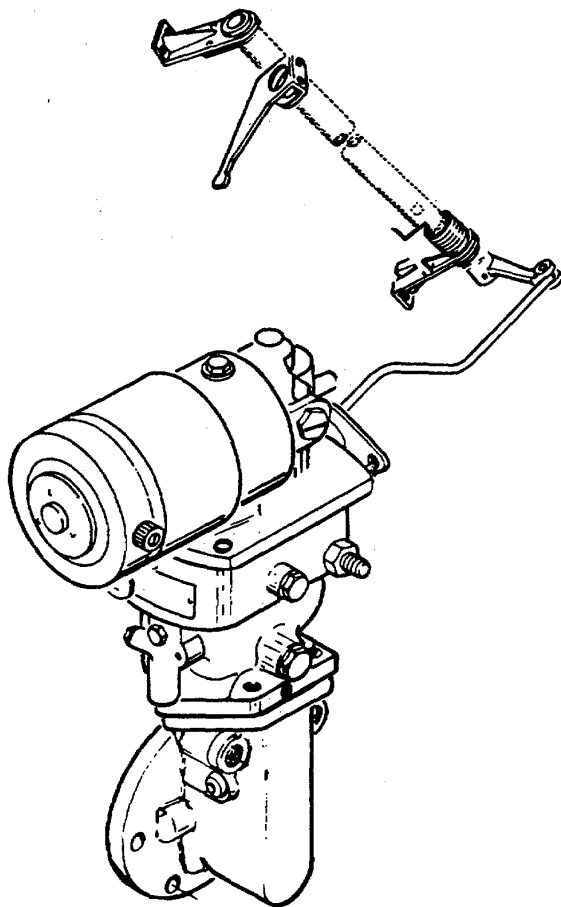

Table 3-24. Generator Engine - Abnormal Engine Operation Troubleshooting (Cont).

| MALFUNCTION | TEST OR INSPECTION | CORRECTIVE ACTION |
|-------------------|--------------------|---|
| 2. Lack of power. | Step 1. | <p>Check for improper engine adjustments, and gear train timing.</p> <p>Perform adjustments in paragraphs 3-66, 3-79, 3-87 and 3-90, if performance is not satisfactory.</p> <p>Check the engine gear train timing. An improperly timed gear train will result in a loss of power due to the valves and injectors being actuated at the wrong time in the engine's operating cycle.</p> <p>Refer to paragraph 3-90.</p> |
| | Step 2. | <p>Check for insufficient fuel.</p> <p>Perform a Fuel Flow Test and, if less than 0.8 gallons per minute with engine at 1200 RPM, consult the No Fuel or Insufficient Fuel Table 3-25.</p> |

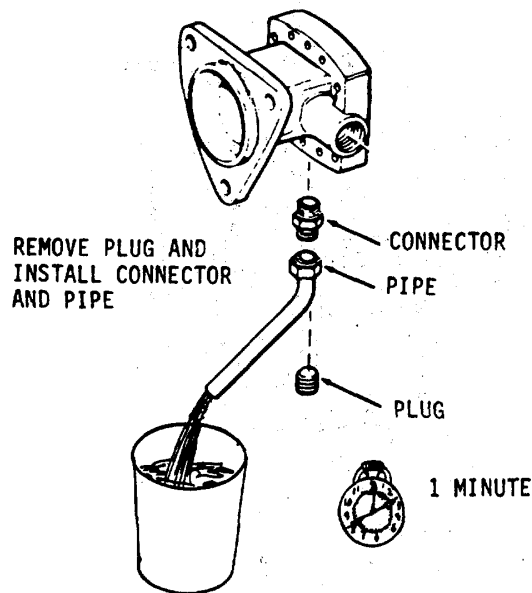

Table 3-24. Generator Engine - Abnormal Engine Operation Troubleshooting (Cont).

| MALFUNCTION |
|--------------------|
| TEST OR INSPECTION |
| CORRECTIVE ACTION |

2. Lack of power (Cont).

Step 3. Check for insufficient air.

a. Check for damaged or dirty air cleaners. Clean, repair or replace damaged parts.

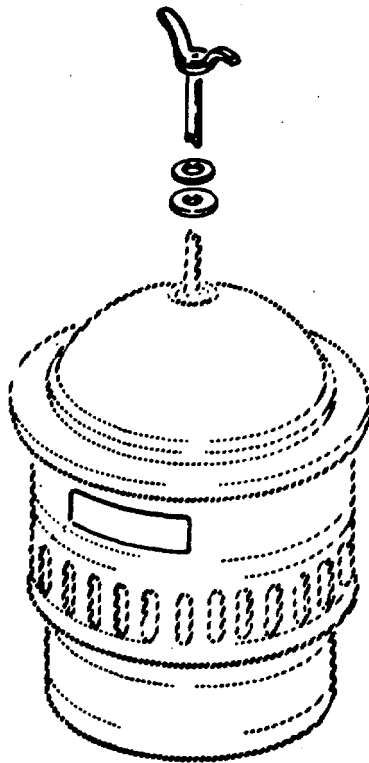

Table 3-24. Generator Engine - Abnormal Engine Operation Troubleshooting (Cont).

| MALFUNCTION | TEST OR INSPECTION | CORRECTIVE ACTION |
|-------------|--------------------|-------------------|
|-------------|--------------------|-------------------|

2. Lack of power (Cont).

- Step 3. b. Remove the air box covers and inspect the cylinder liner ports.
Clean the ports if they are over 50% plugged.

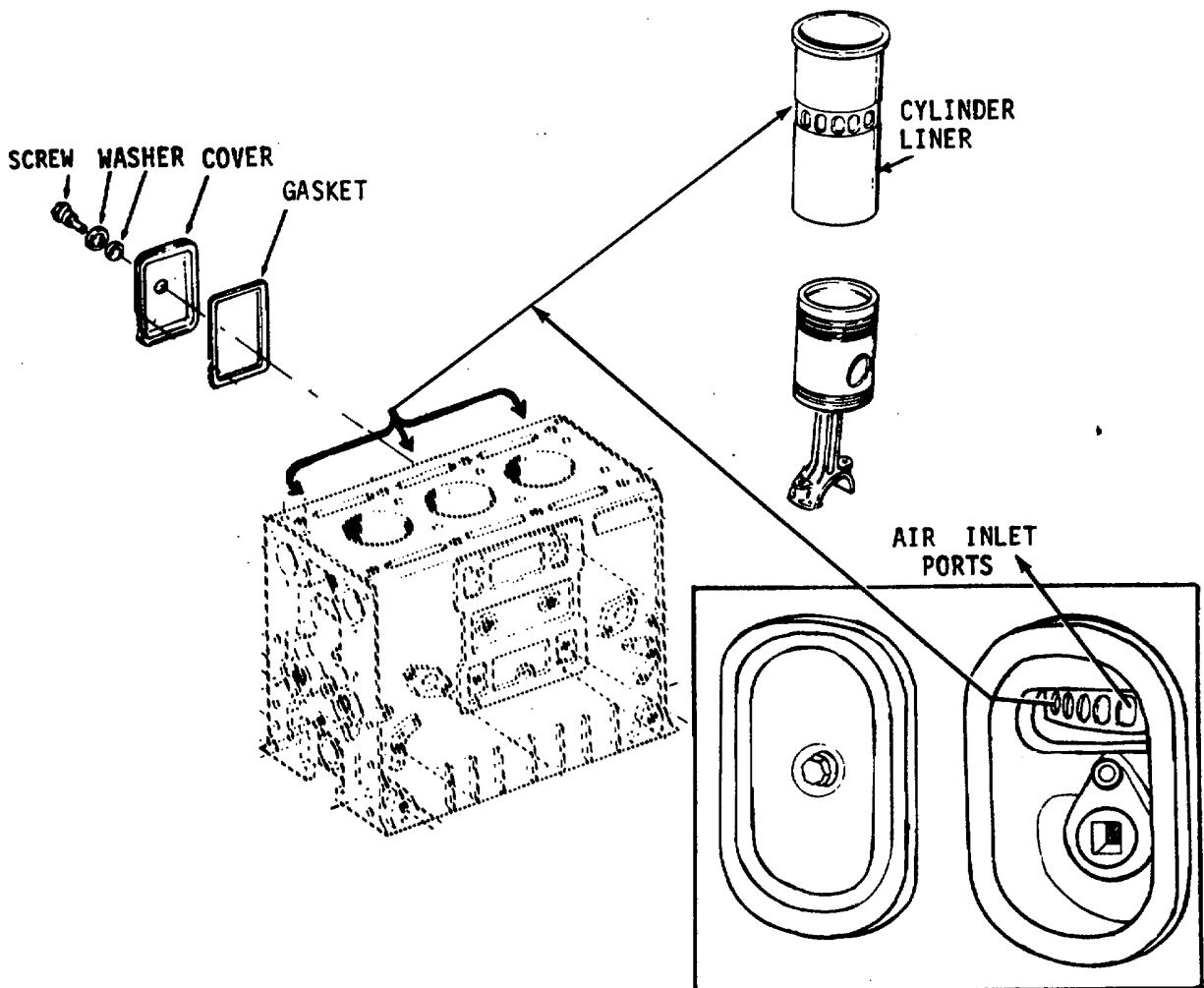

Table 3-24. Generator Engine - Abnormal Engine Operation Troubleshooting (Cont).

| MALFUNCTION | TEST OR INSPECTION | CORRECTIVE ACTION |
|-------------|--------------------|-------------------|
|-------------|--------------------|-------------------|

2. Lack of power (Cont).
 Step 3. c. Check for blower air intake obstruction or high exhaust back pressure.
 Clean, repair or replace faulty parts.

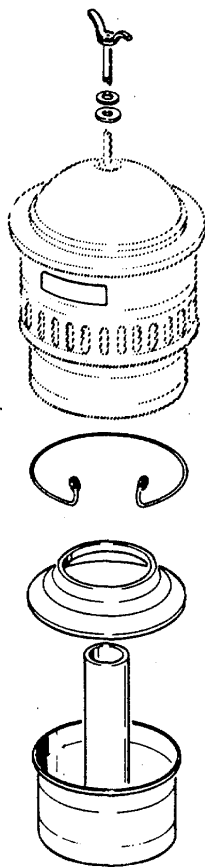

Table 3-24. Generator Engine - Abnormal Engine Operation Troubleshooting (Cont).

MALFUNCTION

TEST OR INSPECTION

CORRECTIVE ACTION

2. Lack of power (Cont).

Step 3. d. Check the compression pressures.

Refer to the Hard Starting Table 3-23.

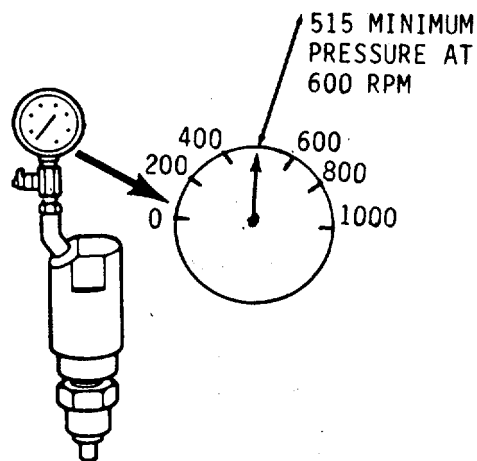

Step 4. Check for incorrect operation of the engine which may result in excessive loads on the engine. Operate the engine according to the approved procedures.

Step 5. Check for high return fuel temperature. Refer to table 3-25.

Step 6. Check for high ambient air temperature.

Check the ambient air temperature. A power decrease of .15 to .50 horsepower per cylinder, depending upon injector size, for each 10oF (5.50C) temperature rise above 90o F (32 C) will occur. Operate ventilation fans to provide a cooler source of air.

Table 3-24. Generator Engine - Abnormal Engine Operation Troubleshooting (Cont).

| MALFUNCTION | TEST OR INSPECTION | CORRECTIVE ACTION |
|-------------|--------------------|-------------------|
|-------------|--------------------|-------------------|

3. Detonation.
- Step 1. Check for oil picked up by air stream.
- a. Fill oil bath air cleaner to the proper level with the same grade and viscosity of OE/HDO lubricating oil that is used in the engine.

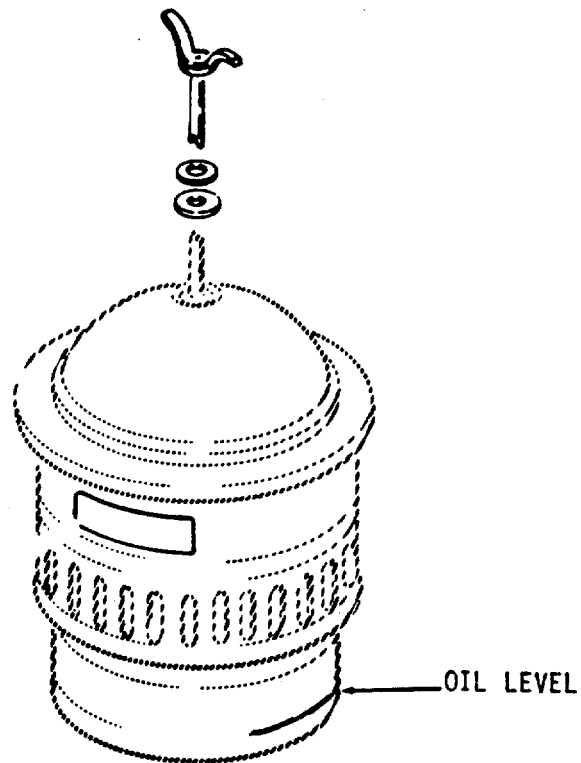

Table 3-24. Generator Engine - Abnormal Engine Operation Troubleshooting (Cont).

| MALFUNCTION | TEST OR INSPECTION | CORRECTIVE ACTION |
|-------------|--------------------|-------------------|
|-------------|--------------------|-------------------|

3. Detonation (Cont).

- Step 1. b. Clean the air box and drain tubes to prevent accumulations that may be picked up by the air stream and enter the engine's cylinders.

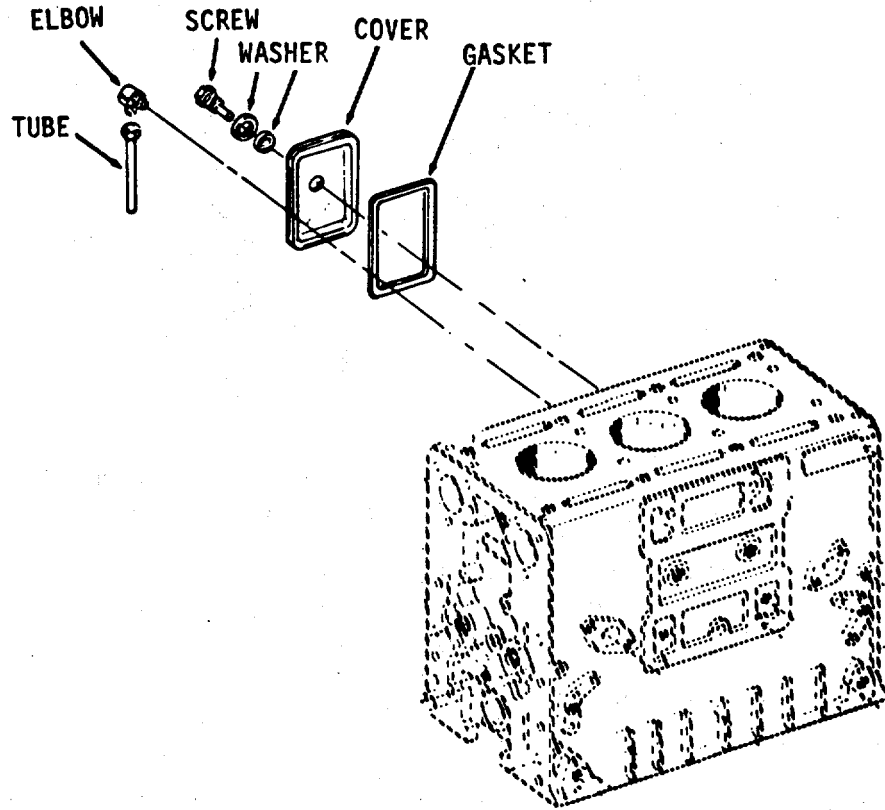
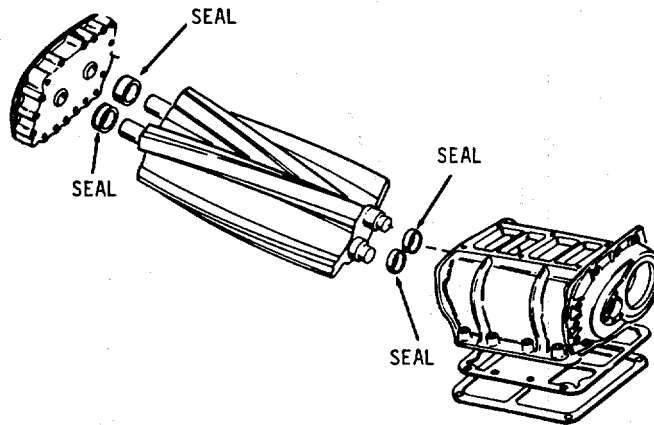

Table 3-24. Generator Engine - Abnormal Engine Operation Troubleshooting (Cont).

| MALFUNCTION | TEST OR INSPECTION | CORRECTIVE ACTION |
|-------------|--------------------|-------------------|
|-------------|--------------------|-------------------|

3. Detonation (Cont).

- Step 1. c. Inspect the blower oil seals by removing the air inlet housing and watching through the blower inlet for oil radiating away from the blower rotor shaft oil seals while the engine is running. If oil is passing through the seals, refer to Direct Support Maintenance.



- d. Check for a defective blower-to-block gasket. Replace the gasket. Refer to paragraph 3-68.

Step 2. Check for low coolant temperature.

Refer to MALFUNCTION 1.

Step 3. Check for faulty injectors.

- a. Check injector timing and the position of each injector rack. Refer to paragraph 3-71 and 3-87.

- b. The erratic operation may be caused by an injector check valve leaking, spray tip holes enlarged, or a broken spray tip. Replace faulty injectors. Refer to paragraph 3-71.

Table 3-25. Generator Engine - No Fuel or Insufficient Fuel Troubleshooting.

| MALFUNCTION | TEST OR INSPECTION | CORRECTIVE ACTION |
|-------------|--------------------|-------------------|
|-------------|--------------------|-------------------|

1. Air leaks.

Step 1. Check for low fuel supply. The fuel tank should be filled above the level of the fuel suction tube.

Step 2. Check for loose connections or cracked lines between fuel pump and tank or suction line in tank.

Perform a Fuel Flow Test and if air is present, tighten loose connections and replace cracked lines. Refer to paragraph 3-72.

NOTE

Fuel flow should be 0.8 gallons per minute with engine at 1200 RPM.

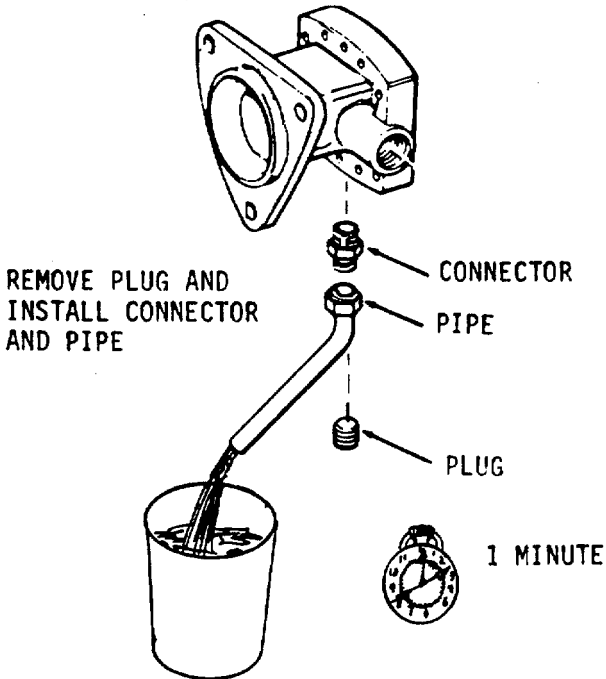

Table 3-25. Generator Engine - No Fuel or Insufficient Fuel Troubleshooting (Cont).

| MALFUNCTION | TEST OR INSPECTION | CORRECTIVE ACTION |
|----------------------|--------------------|--|
| 1. Air leaks (Cont). | Step 3. | Check for damaged fuel oil strainer gasket. Perform a Fuel Flow Test and, if air is present with all fuel lines and connections assembled correctly, check for and replace faulty injectors. Refer to paragraph 3-72. |
| | Step 4. | Faulty injector tip assembly. Perform a Fuel Flow Test and, if air is present with all fuel lines and connections assembled correctly, check for and replace faulty injectors. Refer to paragraph 3-71. |
| 2. Flow obstruction. | Step 1. | Check the fuel strainer or lines for restrictions. Perform a Fuel Flow Test and replace the fuel strainer and filter elements and the fuel lines, if necessary. Refer to paragraph 3-72. |
| | Step 2. | Check for temperature less than 10°F (5.5°C) above pour point of fuel. Use the proper grade of fuel. |

DIESEL FUEL

| TYPE | NATIONAL STOCK NUMBER |
|----------------|-----------------------|
| ARTIC (DF-A) | 9140-00-286-5283 |
| WINTER (DF-W) | 9140-00-286-5286 |
| REGULAR (DF-2) | 9140-00-286-5294 |

Table 3-25. Generator Engine - No Fuel or Insufficient Fuel Troubleshooting (Cont)

| MALFUNCTION | TEST OR INSPECTION | CORRECTIVE ACTION |
|----------------------|---|---|
| 3. Faulty fuel pump. | <p>Step 1. Check for relief valve not seating.</p> <p>Step 2. Check for worn gears or pump body.</p> <p>Step 3. Check for fuel pump not rotating. Check the condition of the fuel pump drive and blower drive and replace defective parts. Refer to paragraphs 3-66, 3-68 and 3-69.</p> | <p>Perform a Fuel Oil Test and, if inadequate, clean and inspect the valve seat assembly. Refer to paragraphs 3-69.</p> <p>Replace the pump, refer to paragraph 3-69.</p> |

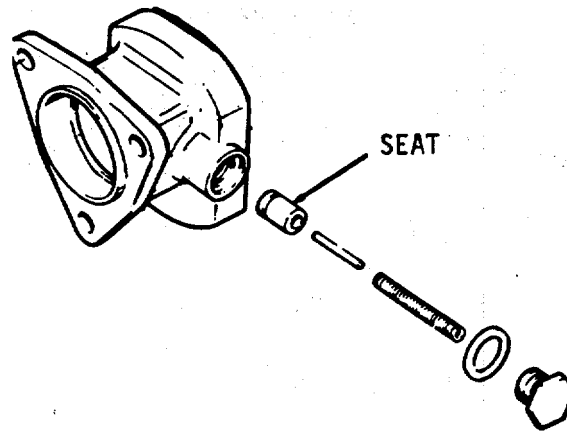

4. Faulty installation.
- Step 1. Check for restricted fitting missing from return line.
- Install a restricted fitting elbow in the return line.

Table 3-25. Generator Engine - No Fuel or Insufficient Fuel Troubleshooting (Cont).

| MALFUNCTION | TEST OR INSPECTION | CORRECTIVE ACTION |
|-------------|--------------------|-------------------|
|-------------|--------------------|-------------------|

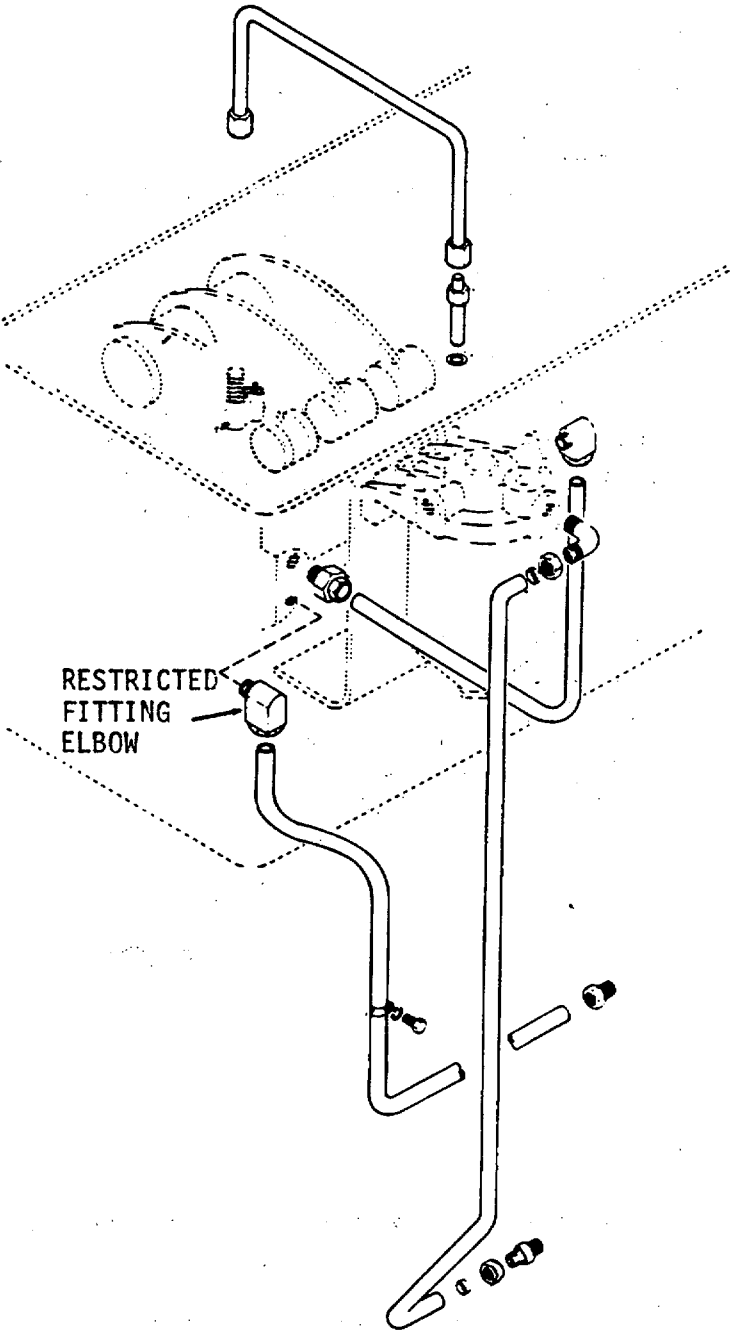

Table 3-25. Generator Engine - No Fuel or Insufficient Fuel Troubleshooting (Cont).

| MALFUNCTION | TEST OR INSPECTION | CORRECTIVE ACTION |
|-------------|--------------------|-------------------|
|-------------|--------------------|-------------------|

4. Faulty installation (Cont).

Step 2. Check for inoperative fuel return line - check lift valve.

Make sure that the check valve is installed in the line correctly; the arrow should be on top of the valve assembly or pointing upward. If the valve is inoperative, replace with a new valve assembly. Refer to paragraph 3-70.

Step 3. Check for high fuel return temperature.

Check the engine fuel spill-back temperature. The return fuel temperature must be less than 150°F (65.5° C) or a loss in horsepower will occur. This condition may be corrected by installing larger fuel lines or using the fuel oil heat exchanger.

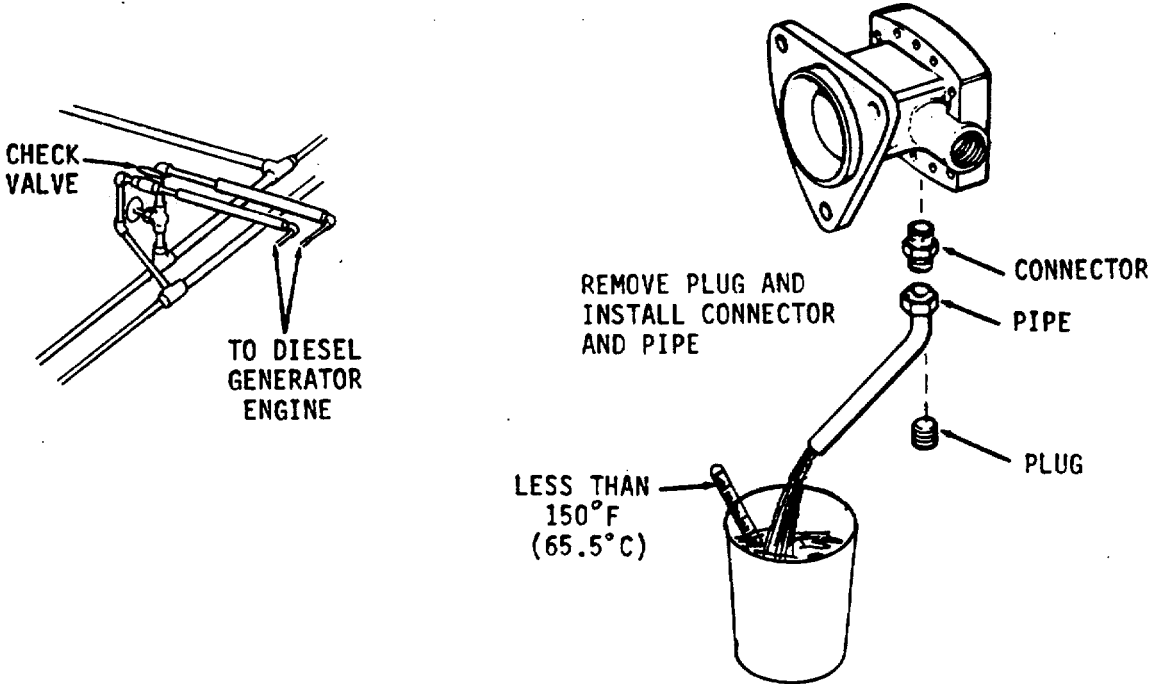

Table 3-26. Generator Engine - High Lubricating Oil Consumption Troubleshooting.

| MALFUNCTION | TEST OR INSPECTION | CORRECTIVE ACTION |
|--------------------|--------------------|--|
| 1. External leaks. | Step 1. | <p>Check oil lines or connections for leaking.</p> <p>Tighten connections or replace defective parts. Refer to paragraph 3-95.</p> |
| | Step 2. | <p>Check for gasket or oil seal leaks.</p> <p>Replace defective gaskets or oil seals. Refer to paragraph 3-95.</p> |
| | Step 3. | <p>Check for high crankcase pressure.</p> <p>Refer to the Excessive Crankcase Pressure Table 3-27.</p> |
| | Step 4. | <p>Check for excessive oil in air box.</p> <p>Refer to the Abnormal Engine Operation Table 3-24.</p> |
| 2. Internal leaks. | Step 1. | <p>Check blower oil seal for leaking.</p> <p>Remove the air inlet housing and inspect the blower end plates while the engine is operating. If oil is seen on the end plate radiating away from the oil seal, refer to Direct Support Maintenance.</p> |
| | Step 2. | <p>Check oil cooler core for leaking.</p> <p>Inspect the engine coolant for lubricating oil contamination; if contaminated, replace the oil cooler core. Then use a good grade of cooling system cleaner to remove the oil from the cooling system. Refer to paragraph 3-95.</p> |

Table 3-26. Generator Engine - High Lubricating Oil Consumption Troubleshooting (Cont).

| MALFUNCTION | TEST OR INSPECTION | CORRECTIVE ACTION |
|-----------------------------|---|-------------------|
| 3. Oil control at cylinder. | Step 1. Check for oil control rings that are worn, broken or improperly installed. Replace the oil control rings. Refer to paragraph 3-96. | |
| | Step 2. Check piston pin retainer for looseness. Replace the piston pin retainer and defective parts. Refer to paragraph 3-96. | |
| | Step 3. Check for scored liners, pistons or oil rings. Remove and replace the defective parts. | |
| | Step 4. Check piston and rod alignment. Check the crankshaft thrust washers for wear. Replace worn and defective parts. Refer to para- graph 3-96. | |
| | Step 5. Check for excessive oil in crankcase. Fill the crankcase to the proper level only. | |

Table 3-27. Generator Engine - Excessive Crankcase Pressure Troubleshooting.

| MALFUNCTION | TEST OR INSPECTION | CORRECTIVE ACTION |
|----------------------|--|-------------------|
| 1. Cylinder blow-by. | Step 1. Check cylinder head gasket for leaks. Check the compression pressure and, if only one cylinder has low compression, remove the cylinder head and replace the head gaskets. Refer to para- graph 3-89. | |

Table 3-27. Generator Engine - Excessive Crankcase Pressure Troubleshooting (Cont).

| MALFUNCTION | TEST OR INSPECTION | CORRECTIVE ACTION |
|-------------|--------------------|-------------------|
|-------------|--------------------|-------------------|

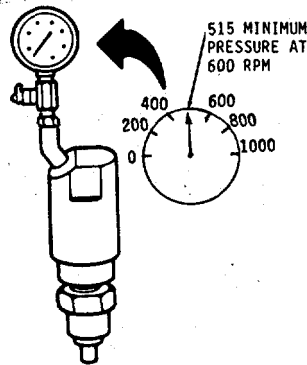

1. Cylinder blow-by (Cont).

Step 2. Check for damaged piston or liner.

Inspect the piston and liner and replace damaged parts. Refer to paragraph 3-96.

Step 3. Check for piston rings that are worn or broken.

Install new piston rings. Refer to paragraph 3-96.

2. Breather restriction.

Step 1. Check for obstruction or damage to breather.

Clean and repair or replace the breather assembly. Refer to paragraph 3-73.

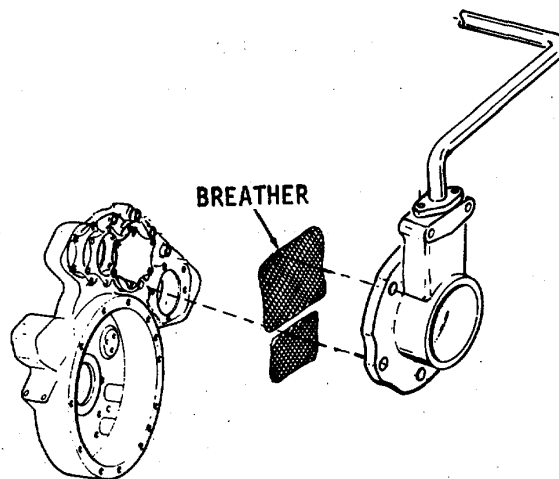

Table 3-27. Generator Engine - Excessive Crankcase Pressure Troubleshooting (Cont).

| MALFUNCTION | TEST OR INSPECTION | CORRECTIVE ACTION |
|-------------|----------------------------------|---|
| 3. | Air from blower or air box. | |
| | Step 1. | Check for damaged blower-to-block gasket. Replace the blower-to-block gasket. Refer to paragraph 3-68. |
| | Step 2. | Check cylinder block end plate gasket for leaking. Replace the end plate gasket. Refer to paragraph 3-98. |
| 4. | Excessive exhaust back pressure. | |
| | Step 1. | Check for excessive muffler resistance. Check the exhaust back pressure and repair or replace the muffler if an obstruction is found. Refer to Direct Support Maintenance. |
| | Step 2. | Check for faulty exhaust piping. Check the exhaust back pressure. Refer to Direct Support Maintenance. |

Table 3-28. Generator Engine - Low Oil Pressure - Troubleshooting.

| MALFUNCTION | TEST OR INSPECTION | CORRECTIVE ACTION |
|-------------|--------------------|-------------------|
|-------------|--------------------|-------------------|

NOTE

- o Make checks with minimum water outlet temperature of 160° F (71° C).
- o An alarm will sound in the pilot house.

1. Lubricating oil.

Step 1. Check for suction loss.

Check the oil and bring it to the proper level on the dipstick.

Step 2. Check lubricating oil viscosity.

Check for the recommended grade and viscosity of oil.

LUBRICATING OIL GRADES

| DESCRIPTION | SPECIFICATION |
|-----------------|-----------------|
| OES (Sub Zero) | MIL - L - 10295 |
| OE/HDO - 10 | MIL - L - 2104 |
| OE/HDO - 20 | MIL - L - 2104 |
| OE/HDO - 30 | MIL - L - 2104 |

Check for fuel leaks at the injector nut seal ring and fuel pipe connections. Leaks at these points will cause lubricating oil dilution. Refer to paragraph 3-72.

2. Poor circulation.

Step 1. Check cooler for clogging.

A plugged oil cooler is indicated by excessively high lubricating oil temperature. Remove and clean the oil cooler core. Refer to paragraph 3-75.

Table 3-28. Generator Engine - Low Oil Pressure Troubleshooting.
(Cont).

| MALFUNCTION | TEST OR INSPECTION | CORRECTIVE ACTION |
|------------------------------------|--------------------|--|
| 2. Poor circulation (Cont). | Step 2. | Check for cooler by-pass valve not functioning properly. |
| | | Remove the by-pass valve and clean the valve and valve seat and inspect the valve spring. Replace defective parts. Refer to paragraph 3-94. |
| | Step 3. | Check for pressure regulator valve that is not functioning properly. |
| | | Remove the pressure regulator valve and clean the valve and valve seat and inspect the valve spring. Replace defective parts. Refer to paragraph 3-94. |
| | Step 4. | Check for excessive wear on crankshaft bearings. |
| | | a. Change the bearings. Refer to paragraph 3-98. |
| | | b. Refer to Lubrication Oil Grades Table for the proper grade and viscosity of oil. |
| | | c. Change the oil filters. Refer to paragraph 3-74. |
| | Step 5. | Check for gallery, crankshaft or camshaft plugs missing. |
| | | Replace missing plugs. Refer to paragraph 3-93. |
| 3. Pressure gage and alarm switch. | Step 1. | Check for faulty gage. |
| | | Check the oil pressure with a reliable gage and replace the gage if found faulty. Refer to paragraph 3-100. |

Table 3-28. Generator Engine - Low Oil Pressure Troubleshooting.
(Cont).

| MALFUNCTION | TEST OR INSPECTION | CORRECTIVE ACTION |
|-------------|--|---|
| 3. | Pressure gage and alarm switch (Cont). | |
| | Step 2. | Check gage line obstruction. Remove and clean the alarm switch line; replace if necessary. Refer to paragraph 3-100. |
| | Step 3. | Check gage orifice for plugging. Remove and clean the alarm switch orifice. Refer to paragraph 3-100. |
| | Step 4. | Check electrical alarm panel for faults (Pilot House). Repair or replace defective electrical equipment. Refer to paragraph 3-65. |
| 4. | Oil pump. | |
| | Step 1. | Check for partially clogged intake screen. a. Remove and clean the oil pan and oil intake screen. Refer to paragraph 3-89, 3-94 and 3-96. b. Consult the Lubrication Oil Grades Table for the proper grade and viscosity of oil. c. Change the oil filters. Refer to paragraph 3-74. |
| | Step 2. | Check for faulty relief valve. Remove and inspect the valve, valve bore and spring. Replace faulty parts. Refer to paragraph 3-94. |
| | Step 3. | Check for air leak in pump suction. Disassemble the piping and install new gaskets. Refer to paragraph 3-95. |

Table 3-28. Generator Engine - Low Oil Pressure Troubleshooting.
(Cont).

| MALFUNCTION | TEST OR INSPECTION | CORRECTIVE ACTION |
|---------------------|--------------------|--|
| 4. Oil pump (Cont). | Step 4. | Check pump for wear or damage. Remove the pump. Clean and replace defective parts. Refer to paragraph 3-95. |
| | Step 5. | Check for flange leak (pressure side). Remove the flange and replace the gasket. Refer to paragraph 3-95. |

Table 3-29. Generator Engine - Abnormal Engine Coolant Operating Temperature Troubleshooting.

| MALFUNCTION | TEST OR INSPECTION | CORRECTIVE ACTION |
|---|--------------------|--|
| NOTE An alarm will sound in the pilot house. | | |
| 1. Temperature above normal. | Step 1. | Check for insufficient heat transfer. Clean the cooling system with a good cooling system cleaner and thoroughly flush to remove scale deposits. |
| | Step 2. | Check for poor circulation. <ul style="list-style-type: none"> a. Check the coolant level and fill to the filler neck if the coolant level is low. b. Inspect for collapsed or disintegrated hoses. Replace faulty hoses. Refer to paragraph 3-76. |

Table 3-29. Generator Engine - Abnormal Engine Coolant Operating Temperature Troubleshooting (Cont).

| MALFUNCTION | TEST OR INSPECTION | CORRECTIVE ACTION |
|-------------------------------------|--|---|
| 1. Temperature above normal (Cont). | | |
| Step 2. | c. | Thermostat may be inoperative. Remove, inspect and test the thermostat. Replace if found faulty. Refer to paragraph 3-78. |
| | d. | Check the water pump for a loose or damaged impeller. Refer to paragraph 3-75. |
| | e. | Check the flow of coolant through the expansion tank and keel coolers. A clogged expansion tank or keel cooler will cause an inadequate supply of coolant on the suction side of the pump. Clean the expansion tank and keel coolers. Refer to paragraph 3-76 and Direct Support Maintenance. |
| | f. | Remove the coolant filler cap and operate the engine, checking for combustion gases in the cooling system. The cylinder head must be removed and inspected for cracks and the head gaskets replaced if combustion gases are entering the cooling system. Refer to paragraph 3-89. |
| | g. | Check for an air leak on the suction side of the water pump. Replace defective parts. Refer to paragraph 3-75. |
| 2. Temperature below normal. | | |
| Step 1. | Check for improper circulation. | |
| | The thermostat may not be closing. Remove, inspect and test the thermostat. Install a new thermostat, if necessary. Refer to paragraph 3-78. Check for an improperly installed heater. | |
| Step 2. | Check for excessive leakage at thermostat seal. | |
| | Excessive leakage of coolant past the thermostat seal(s) is a cause of continued low coolant operating temperature. When this occurs, replace the thermostat seal(s). Refer to paragraph 3-78. | |

Table 3-30. Generator Engine - Low or High Exhaust Valve Opening Pressure Troubleshooting.

| MALFUNCTION | TEST OR INSPECTION | CORRECTIVE ACTION |
|---|--------------------|---|
| 1. Low exhaust valve opening pressure.- | Step 1. | Check for worn or eroded valve seat. Replace worn or eroded valve seat. Refer to paragraph 3-89. |
| | Step 2. | Check valve seat for chips at point of contact with valve. Replace valve seat. Refer to paragraph 3-89. |
| | Step 3. | Check for cracked valve seat. Replace the valve seat. Refer to paragraph 3-89. |
| | Step 4. | Check for worn valve or valve locks. Replace the valve or valve locks. Refer to paragraph 3-90. |
| | Step 5. | Check for worn or broken valve spring. Replace the spring. Check the valve cage and valve stop for wear; replace them if necessary. Refer to paragraph 3-90. |
| | Step 6. | Check for dirt or foreign material in injector. Replace the injector. Refer to paragraph 3-71. |
| | Step 7. | Check for worn valve spring stop seat. Replace the valve spring stop. Refer to paragraph 3-89. |
| 2. High valve opening pressure. | Step 1. | Check for carbon or foreign material in injector if spray tip. Replace injector. Refer to paragraph 3-71. |

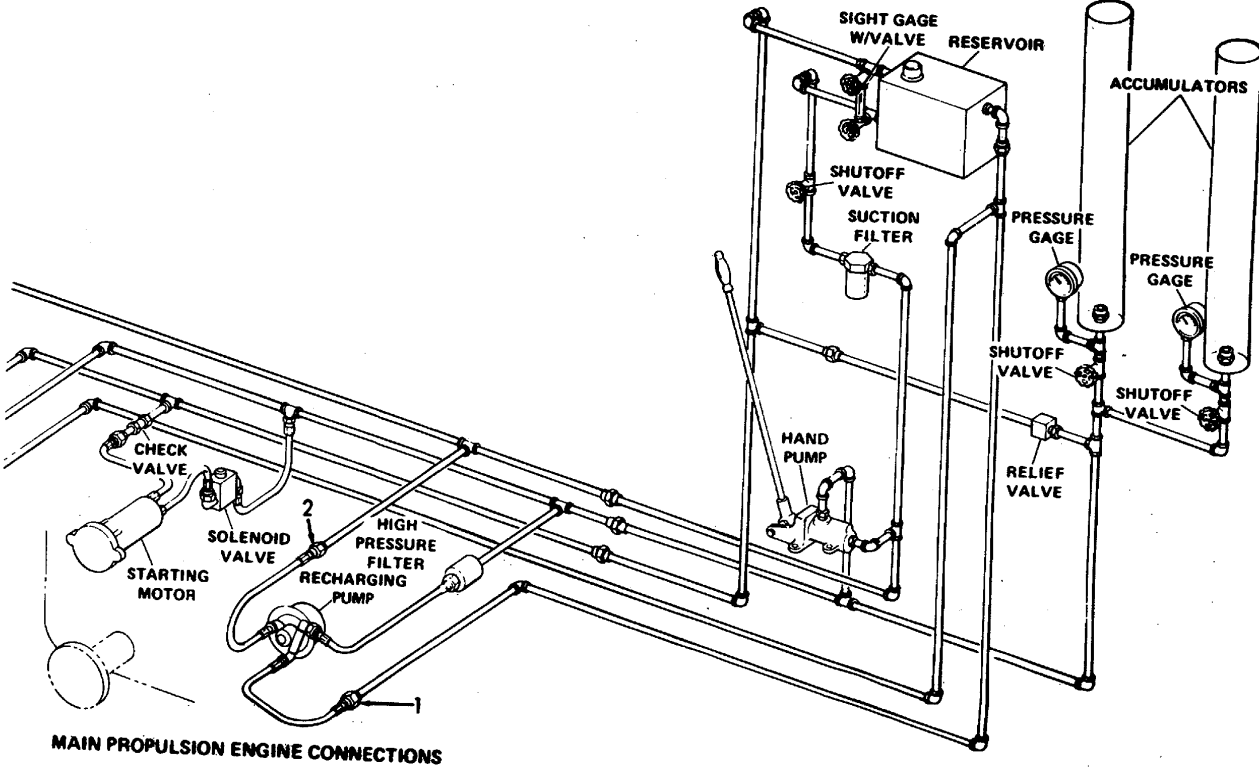

MAIN PROPULSION ENGINE CONNECTIONS

Table 3-31. Hydrostarter - Low or No Accumulator Pressure Troubleshooting.

| MALFUNCTION | TEST OR INSPECTION | CORRECTIVE ACTION |
|-------------|--------------------|-------------------|
|-------------|--------------------|-------------------|

1. Engine driven pump fails to raise pressure.

Step 1. Check for air in system.

To purge the engine driven pump of air:

- a. Operate the engine at maximum no-load engine speed.
- b. Break the hose connection (1) on the pressure side of the engine-driven pump until a full stream of oil is discharged from the pump.
- c. Connect the hose to the pump and alternately loosen and tighten the swivel fitting (2) on the pressure hose until the oil leaking out when the fitting is loose appears free of air bubbles.
- d. Tighten the swivel fitting securely and observe the pressure gage. The pressure must rise rapidly to the accumulator precharge pressure (1250 psi at 70°F) (8274 kPa at 68.4°C). Then increase slowly to 2900 to 3300 psi (19996 to 22754 kPa) in 6 to 10 minutes, depending upon size of the particular accumulator.

Table 3-31. Hydrostarter - Low or No Accumulator Pressure Troubleshooting (Cont).

| MALFUNCTION | TEST OR INSPECTION | CORRECTIVE ACTION |
|-------------|--------------------|-------------------|
|-------------|--------------------|-------------------|

- 1. Engine driven pump fails to raise pressure (Cont).
 - e. If the accumulator pressure does not rise, make certain that the hand pump relief valve (3) is closed after the pressure is released and repeat the above purging procedure.

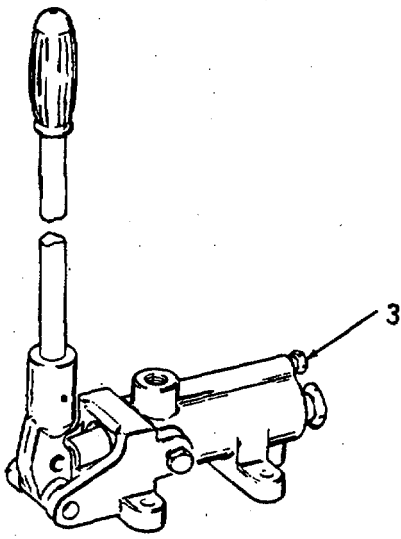

Step 2. Check for low fluid level.

The fluid level in the reservoir must be sufficient to completely cover the screen at the bottom of the tank after the accumulator is charged and the engine-driven pump is by-passing a full stream of fluid to the reservoir.

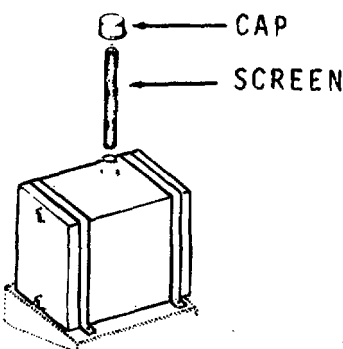

Table 3-31. Hydrostarter - Low or No Accumulator Pressure Troubleshooting (Cont).

| MALFUNCTION | TEST OR INSPECTION | CORRECTIVE ACTION |
|-------------|--------------------|-------------------|
|-------------|--------------------|-------------------|

1. Engine driven pump fails to raise pressure (Cont).

Step 3. Check for plugged screen or filter.

- a. Remove and clean the reservoir screen and flush out the reservoir tank. Refer to paragraph 3-107.
- b. Clean the filter located in the supply hose between the reservoir and the engine-driven pump. Refer to paragraph 3-107.

Step 4. Check for check valves not functioning properly.

- a. Open the relief valve (3) on the side of the hand pump, while the engine is running, to permit the engine-driven pump to wash the check valves free from particles.
- b. If the accumulator can be charged with the hand pump but not with the engine-driven pump, then a check valve in the engine pump is defective. Replace the faulty check valve assembly. Refer to paragraph 3-103.

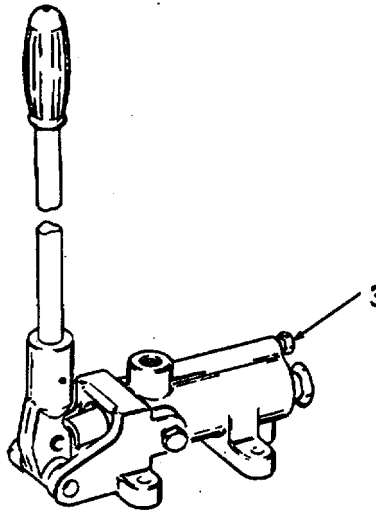

Step 5. Check for defective drive.

Replace the pump drive arm. Refer to paragraph 3-103.

Table 3-32. Hydrostarter - Cranking Speed Too Low Troubleshooting.

| MALFUNCTION | TEST OR INSPECTION | CORRECTIVE ACTION |
|-------------|--------------------|-------------------|
|-------------|--------------------|-------------------|

1. Cranking speed to low.

- Step 1. Check that hydrostarter system fluid is not too heavy.
Check the fluid in the system. Use Hydraulic Fluid MIL-L-17672 type 2135 TH.
- Step 2. Check that engine oil is not too heavy.
Replace the oil with the proper viscosity grade.

LUBRICATING OIL GRADES

| DESCRIPTION | SPECIFICATION |
|----------------|-----------------|
| OES (Sub Zero) | MIL - L - 10295 |
| OE/HDO - 10 | MIL - L - 2104 |
| OE/HDO - 20 | MIL - L - 2104 |
| OE/HDO - 30 | MIL - L - 2104 |

- Step 3. Check for control valve that is not fully open.
Valve body sticking in valve housing. Replace valve cage and valve assembly.
- Step 4. Check for inlet line restricted.
Check plumbing from accumulator to hydrostarter to insure hoses are not collapsed and are free of obstructions.
- Step 5. Check for excessive internal leakage in hydrostarter.
Examine around hydrostarter for broken thrust bearing plate, scored port plate, frozen piston or broken cylinder spring.

Table 3-33. Hydrostarter - Loss of Fluid from Reservoir Troubleshooting.

| MALFUNCTION | TEST OR INSPECTION | CORRECTIVE ACTION |
|----------------------------------|--|---|
| 1. Loss of fluid from reservoir. | Step 1. Check for external leaks. | With pressure in the system, check all hoses and fittings for leaks. Tighten the fittings. Refer to Direct Support Maintenance. |
| | Step 2. Check for leaking hydrostarter shaft seal. | Remove hydrostarter inspection cover and look for signs of hydraulic oil on the Bendix drive, the Hydrostarter shaft and inside the pinion gear housing. Refer to Direct Support Maintenance. |
| | Step 3. Check for leaking engine pump shaft seal. | Refer to Direct Support Maintenance. |
| | Step 4. Check for leaking hand pump seal. | Remove plunger gland and replace inner and outer O-rings. |

Table 3-34. Hydrostarter - Loss of Fluid Pressure When Engine is Not Running - Troubleshooting.

| MALFUNCTION | TEST OR INSPECTION | CORRECTIVE ACTION |
|---|---|---|
| 1. Loss of fluid pressure when engine is not running. | Step 1. Check for ambient temperature decrease. | A drop in temperature will decrease the nitrogen pressure. Adjust the pressure as needed for cranking requirements by use of the hand pump. |

Table 3-34. Hydrostarter - Loss of Fluid Pressure When Engine is Not Running - Troubleshooting.

| MALFUNCTION | TEST OR INSPECTION | CORRECTIVE ACTION |
|---|--------------------|--|
| 1. Loss of fluid pressure when engine is not running (Cont) | Step 2. | <p>Check for engine driven pump check valves not holding.</p> <p>Disconnect the return hose and inlet hose from the engine-driven pump. Leakage from the inlet fitting means that both check valves are defective. Leakage at the return fitting means that only outlet check valve is defective. Replace the defective check valve assembly(s). Refer to paragraph 3-103.</p> |
| | Step 3. | <p>Check for hand pump valves for not holding.</p> <p>Disconnect the inlet hose from the hand pump. Leakage from the inlet fitting means that either the relief valve alone or both the inlet and outlet check valves are defective. Stone and clean the ball seats in the pump body and replace the balls and springs if necessary. Refer to paragraph 3-104.</p> |
| | Step 4. | <p>Check for damaged seal ring in starter control valve shown by external leakage.</p> <p>Refer to Direct Support Maintenance.</p> |
| | Step 5. | <p>Check for external leakage in system.</p> <p>Examine all hoses and fittings for leaks. Tighten. Refer to Direct Support Maintenance. Step 6. Check for loss of accumulator precharge (nitrogen).</p> <p>See table 3-37.</p> |

Table 3-35. Hydrostarter - Hand Pump Fails to Discharge Fluid Troubleshooting.

| MALFUNCTION | TEST OR INSPECTION | CORRECTIVE ACTION |
|-------------|--------------------|-------------------|
|-------------|--------------------|-------------------|

1. Hand pump fails to discharge fluid.

Step 1. Check for open manual relief valve.

Close the relief valve.

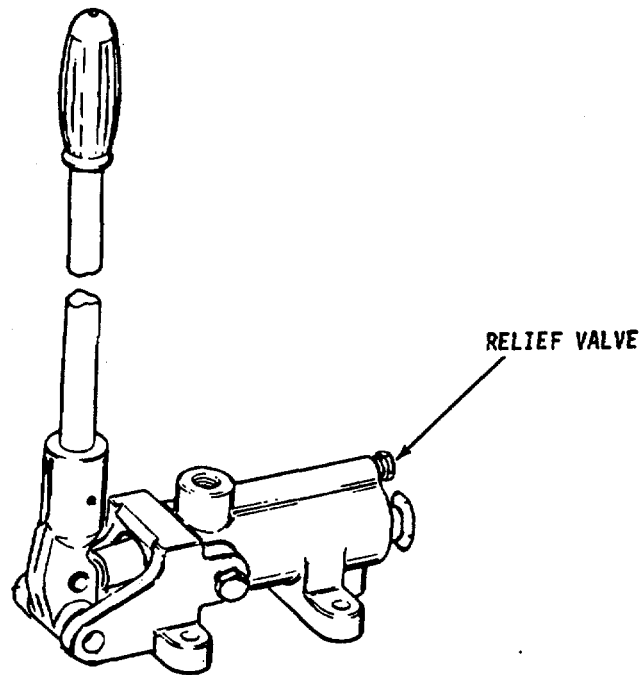

Step 2. Check for leaking check valves.

Hand pump handle will not stay in neutral position but will move to one end of the stroke. If caused by dirt, open the relief valve and operate the hand pump slowly for a few minutes to wash the particles out of the check valves. If this is unsuccessful, stone and clean the ball seats in the pump body and replace the balls and springs if necessary. Refer to paragraph 3-104.

Table 3-35. Hydrostarter - Hand Pump Fails to Discharge Fluid Troubleshooting (Cont).

| MALFUNCTION | TEST OR INSPECTION | CORRECTIVE ACTION |
|---|--------------------|---|
| 1. Hand pump fails to discharge fluid (Cont). | Step 3. | <p>Check for plugged reservoir screen.</p> <p>Remove and clean the reservoir screen, flush the reservoir tank and reassemble. Refer to Direct Support Maintenance.</p> |
| | Step 4. | <p>Check for low fluid level.</p> <p>See table 3-11, step 2.</p> |
| | Step 5. | <p>Check for air in system.</p> <p>To purge the hand pump of air:</p> <ol style="list-style-type: none"> a. Relieve any system pressure, then disconnect the outlet hose from the hand pump. b. Close the manual relief valve and operate the pump until fluid is discharged when stroking in both directions. c. Reconnect the outlet hose. |
| | Step 6. | <p>Check for dirt in pump.</p> <p>See step 2.</p> |
| | Step 7. | <p>Check for damaged piston seal rings.</p> <p>Replace the seal rings. Refer to paragraph 3-104.</p> |

Table 3-36. Hydrostarter - Starter Turns but Engine Does Not Troubleshooting.

| MALFUNCTION | TEST OR INSPECTION | CORRECTIVE ACTION |
|---|--|--|
| 1. Starter turns but engine does not - troubleshooting. | Step 1. Check for pinion not engaging in flywheel ring gear. | Replace as per paragraph 3-101. Refer to Direct Support Maintenance. |
| | Step 2. Check for broken bendix drive. | Replace Bendix drive. Operator should disengage hydrostarter as soon as engine starts. Prolonging the period during which clutch overruns will reduce clutch life. |

Table 3-37. Hydrostarter - Loss of Accumulator Precharge (Nitrogen) Troubleshooting.

| MALFUNCTION | TEST OR INSPECTION | CORRECTIVE ACTION |
|--|--|---|
| 1. Loss of accumulator precharge (nitrogen). | Step 1. Check for damaged seal ring on piston. | With some nitrogen precharge but no fluid pressure in the system, bubbles and foaming in the reservoir indicate that the nitrogen is leaking past the seal ring on the accumulator piston. Refer to Direct Support Maintenance. |

Table 3-37. Hydrostarter - Loss of Accumulator Precharge (Nitrogen) Troubleshooting (Cont).

| MALFUNCTION | TEST OR INSPECTION | CORRECTIVE ACTION |
|-------------|--------------------|-------------------|
|-------------|--------------------|-------------------|

1. Loss of accumulator precharge (nitrogen).

Step 2. Check for defective air valve.

Release the pressure in the system by opening the relief valve on the side of the hand pump. Then, loosen the hex lock nut on the nitrogen valve approximately 3/4 turn to release the remaining precharge before attempting to remove the valve from the accumulator. Replace the air valve. Refer to Direct Support Maintenance.

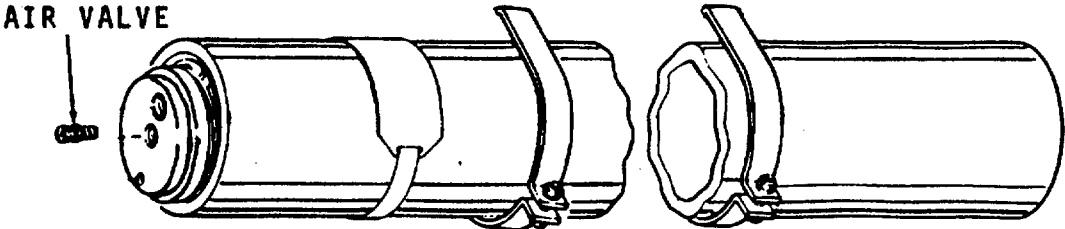

Step 3. Check for damaged seal ring between shell and end cap.

Apply light oil on the threaded end of the accumulator at the end of the cap. Bubbling of the oil indicates a leak past the end cap seal. Refer to Direct Support Maintenance.

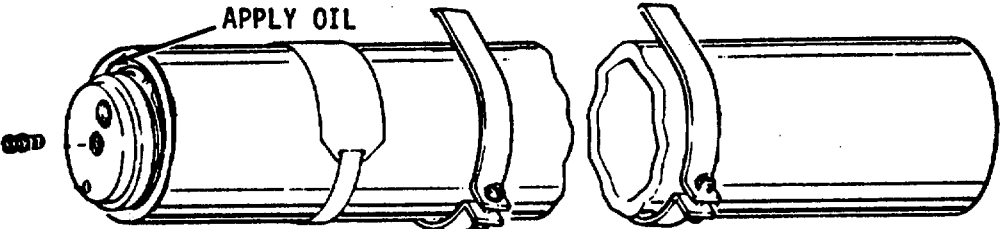

Step 4. Check for defective safety fuse.

Replace safety fuse assembly after releasing all nitrogen pressure. Refer to Direct Support Maintenance.

Table 3-38. Hydrostarter - High Pressure in System (3500 psi or above) Troubleshooting.

| MALFUNCTION | TEST OR INSPECTION | CORRECTIVE ACTION |
|---|--|--------------------------------------|
| 1. High pressure in system - 3500 psi (24133 kPa) or above. | Step 1. Check for defective gage. | Refer to Direct Support Maintenance. |
| | Step 2. Check for engine driven pump unloading valve not operating properly. | Refer to Direct Support Maintenance. |

Table 3-39. Hydrostarter - Fluid Emerges from the Reservoir Filler Cap When Starter is Used - Troubleshooting.

| MALFUNCTION | TEST OR INSPECTION | CORRECTIVE ACTION |
|--|--|--|
| 1. Fluid emerges from the reservoir filler cap when starter is used. | Step 1. Check for filter element in filler cap loaded with dirt. | Rinse the filler cap thoroughly in fuel oil and dry it with compressed air. |
| | Step 2. Check for nitrogen in fluid returned to reservoir. Overhaul the accumulator. See table 3-37. | |
| | Step 3. Check for excess fluid in reservoir. | Check the fluid level when the accumulator is empty. The fluid level should be approximately 2-1/2 inches (6.4 cm) from the top of the tank. |

Table 3-40. Hydrostarter - Fluid Emerges Around Rubber Boot of Hand Pump - Troubleshooting.

| MALFUNCTION | TEST OR INSPECTION | CORRECTIVE ACTION |
|---|--|--|
| 1. Fluid emerges around rubber boot of hand pump. | Step 1. Check for damaged piston seal rings. | Replace the seal rings and leather back-up rings on the pump piston. Refer to paragraph 3-104. |
| | Table 3-41. Hydrostarter - Cranking Cycle Too Short - Troubleshooting. | |

| MALFUNCTION | TEST OR INSPECTION | CORRECTIVE ACTION |
|---------------------------------|---|---|
| 1. Cranking cycle is too short. | Step 1. Check for faulty pressure gage. | If gage is reading higher than actual system pressure, oil volume in the accumulator will be less. Replace gage. |
| | Step 2. Check for excessive internal leakage in hydrostarter. | Refer to table 3-32. |
| | Step 3. Check for accumulator precharge too high. | With the fuel shut off to prevent engine from starting, crank the engine until all oil is used. If the gage then registers zero pressure, install a gaging assembly on the air valve and drop the precharge to 1250 psi (1695 kPa). Repeat cranking cycle. If gage will still drop to zero at end of cranking cycle, reduce precharge to 1000 psi (1356 kPa). |

Table 3-41. Hydrostarter - Cranking Cycle Too Short - Troubleshooting (Cont).

| MALFUNCTION | TEST OR INSPECTION | CORRECTIVE ACTION |
|-------------|--------------------|-------------------|
|-------------|--------------------|-------------------|

1. Cranking cycle is too short (Cont).

Step 4. Check for accumulator precharge too low.

Open the bypass valve on the hand pump to discharge oil from the accumulator. Install a gaging assembly on the accumulator air valve. If precharge is less than 1500 psi (2034 kPa) add nitrogen. Make sure pre-charge holds by testing for nitrogen leakage. Refer to table 3-37.

Table 3-42. Generator - Troubleshooting

NOTE

Most of the generator problems are diagnosed from the switchboard located in the engine access room. Refer to table 3-43 for switchboard troubleshooting.

| MALFUNCTION | TEST OR INSPECTION | CORRECTIVE ACTION |
|-------------|--------------------|-------------------|
|-------------|--------------------|-------------------|

- 1. Generator Overheats.
 - Step 1. Check the generator covers and cooling fins by observation.
If air passages are dirty - clean.
 - Step 2. Check for overloaded.
Refer to table 3-43.
 - Step 3. Check for unbalanced load.
Check switchboard and balance generators. Refer to paragraph 2-34.

Table 3-42. Generator - Troubleshooting (Cont).

| MALFUNCTION | TEST OR INSPECTION | CORRECTIVE ACTION |
|-------------|--------------------|-------------------|
|-------------|--------------------|-------------------|

2. Generator Noisy.

Step 1. Listen for defective bearings.

- a. Check oil level in sightglass - Add oil type OE/HDO.
- b. Bad bearing - Refer to Direct Support Maintenance.

Step 2. Check for damaged fan.

- a. Inspect fan for cracks, breaks, insufficient mounting and looseness. Refer to paragraph 3-63.
- b. Inspect mounting of generator to engine - tighten bolts and refer to paragraph 3-62.

WARNING

Be sure generator is off. Tag switchboard to prevent accidental starting.

3. No Output.

Step 1. Check internal wiring - Burned, broken, worn or loose.

Tighten loose wire connection.

Insulate worn wires.

Refer all other problems to Direct Support Maintenance.

Step 2. Inspect for defective external wiring.

Refer to Direct Support Maintenance.

Table 3-43. Switchboard Troubleshooting.

WARNING

-

HIGH VOLTAGE
is used in operation of this equipment.

-

DEATH ON CONTACT

may result if safety precautions are not observed. Remember 450 volts in a salt water atmosphere can be deadly. There are three potential sources of power: Generator 1, Generator 2, and Shore power.

Place warning tags (red) on generator instrument panels on the forward and aft engine room, to prevent accidental starting of generators.

-

NOTE

Prior to starting troubleshooting the switch board and generators, perform the operating procedures in paragraph 2-35. When a problem occurs, consult this table for a possible solution after observing the front panel meters.

MALFUNCTION

TEST OR INSPECTION
CORRECTIVE ACTION

- 1. Starter cranks generator but stops when start switch is released.
 - Step 1. Check for defective start solenoid.
Replace. Refer to paragraph 3-52.
 - Step 2. Check for defective start switch.
Refer to Direct Support Maintenance.

Table 3-43. Switchboard Troubleshooting (Cont).

| MALFUNCTION | TEST OR INSPECTION | CORRECTIVE ACTION |
|--|--|---|
| 2. Generator fails to supply power to switchboard, as shown on volt meter: It should read 450 VAC. | Step 1. Check for loose, cut, broken, burned and worn wiring. | Tighten or replace defective wiring. Refer to paragraph 3-59. |
| | Step 2. Check for voltmeter switch (Generator 2/Shorepower) in wrong position. | Place switch in Generator 2 position. |
| | Step 3. Check for defective voltmeter. | Refer to Direct Support Maintenance. |
| | Step 4. Check for defective voltmeter switch. | Refer to Direct Support Maintenance. |
| 3. Generator fails to build up to rated voltage. | Step 1. Check for incorrect adjustments. Perform operating procedures. | |
| | Step 2. Check for loose, cut, broken and worn wiring. | If connections are loose, tighten them. If wiring is damaged, repair it. Refer to paragraph 3-59. |
| | Step 3. Check for defective voltage regulator. | Refer to Direct Support Maintenance. |
| | Step 4. Check for broken or damaged switches, meters, or rheostats. | Refer to Direct Support Maintenance. |

Table 3-43. Switchboard Troubleshooting (Cont).

| MALFUNCTION | TEST OR INSPECTION | CORRECTIVE ACTION |
|-------------|--------------------|-------------------|
|-------------|--------------------|-------------------|

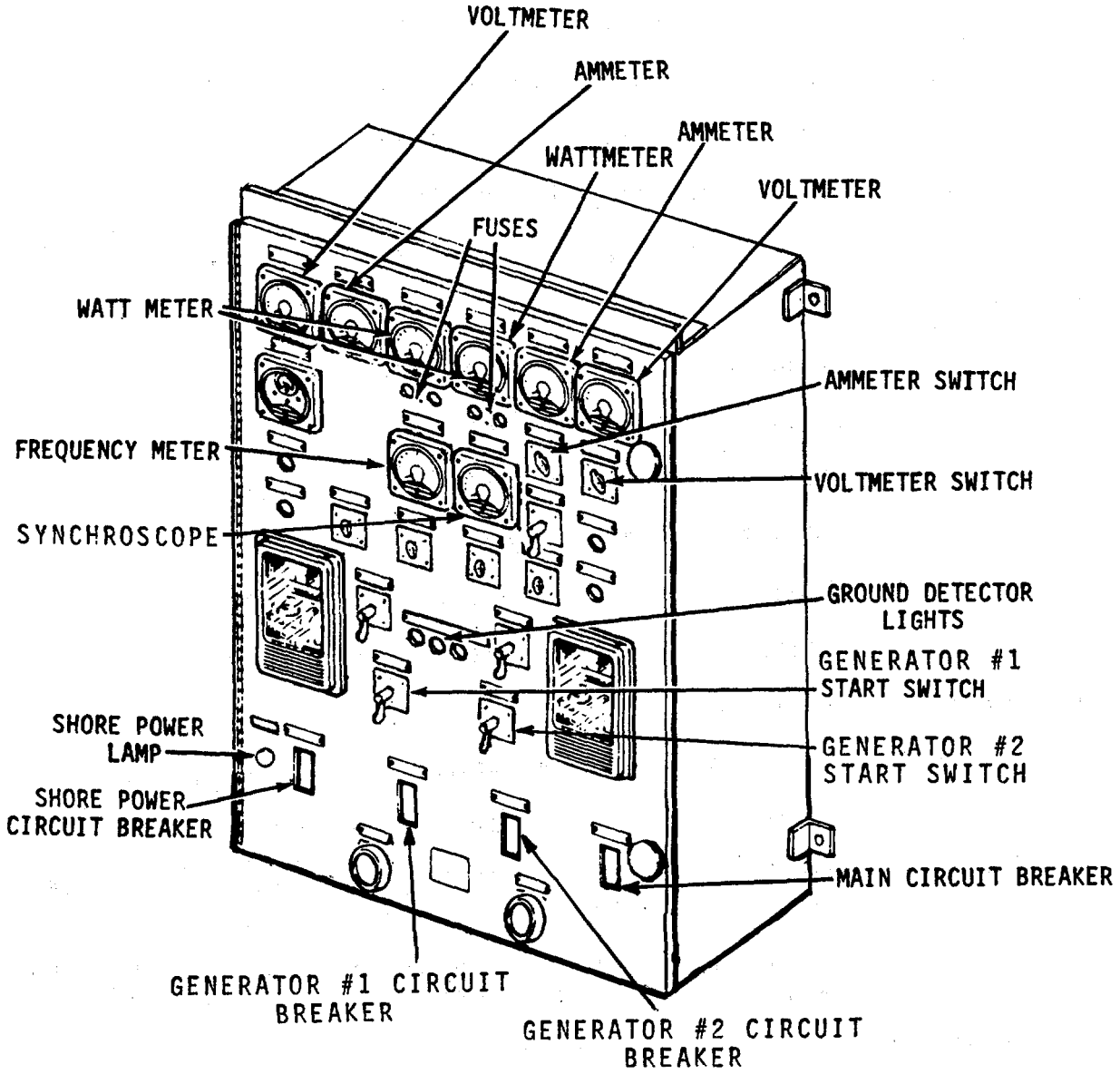

Table 3-43. Switchboard Troubleshooting (Cont).

| MALFUNCTION | TEST OR INSPECTION | CORRECTIVE ACTION |
|---|--------------------|---|
| 4. Voltmeter reading too high or too low. | Step 1. | Check for incorrect adjustments. Perform operating procedures. |
| | Step 2. | Check for defective voltage regulator. Refer to Direct Support Maintenance. |
| | Step 3. | Check for defective voltmeter. Refer to Direct Support Maintenance. |
| 5. No power to load. | Step 1. | Check main circuit breaker. Reset circuit breaker. |
| | Step 2. | Check distribution circuit breaker. Reset circuit breaker. |
| | Step 3. | Check for defective circuit breaker. Refer to Direct Support Maintenance. |
| 6. Ammeter fails to read. | Step 1. | Check for defective ammeter. Refer to Direct Support Maintenance. |
| | Step 2. | Check for ammeter switch (Generator 2/Shorepower) in wrong position. Place in Generator 2 position. If problem continues, refer to Direct Support Maintenance. |
| 7. Generator frequency meter fails to read. | Step 1. | Check for frequency meter switch in wrong position. Place switch in correct position. |





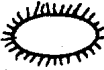







Table 3-43. Switchboard Troubleshooting (Cont).

| MALFUNCTION | TEST OR INSPECTION | CORRECTIVE ACTION |
|--|---|---|
| 7. Generator frequency meter fails to read (Cont). | Step 2. Check for defective frequency meter. Refer to Direct Support Maintenance. | Step 3. Check for defective frequency meter switch. Refer to Direct Support Maintenance. |
| 8. Wattmeter fails to read. | Step 1. Check for neon light visible in fuse holder. Blown fuse, replace. Refer to paragraph 3-59. | Step 2. Check for ammeter switch (Generator 2/Shorepower) in wrong position. Place in Generator 2 position. If problem continues, refer to Direct Support Maintenance. |
| | Step 3. Check for defective wattmeter. Refer to Direct Support Maintenance. | Step 4. Check for defective fuse holder. Refer to paragraph 3-59. |
| 9. Shore power not available. | Step 1. Check for shore power energized lamp not lit. a. Lamp loose in socket. b. Defective lamp. Replace. Refer to paragraph 3-59. c. Defective lamp holder. Refer to paragraph 3-59. | Step 2. Check wiring. Check or correct wiring from the source of power to the Shore Power Box. |

Table 3-43. Switchboard Troubleshooting (Cont).

| MALFUNCTION | TEST OR INSPECTION | CORRECTIVE ACTION |
|---|--|--------------------------------------|
| 9. Shore power not available (Cont). | Step 3. Check for shore power not turned on at source. | Turn power on. |
| 10. Shore power available - but not to load. | Step 1. Check shore power circuit breaker. | Reset circuit breaker. |
| | Step 2. Check distribution circuit breaker. | Reset circuit breaker. |
| | Step 3. Check defective circuit breaker. | Refer to Direct Support Maintenance. |
| 11. Generator frequency drifts, generator runs irratically. | Step 1. Check for defective governor on generator. | Replace. Refer to paragraph 3-66. |
| 12. Generators do not parallel properly. | Step 1. Check for defective governor on engine. | Refer to paragraph 3-66. |
| | Step 2. Check for improper adjustment. | Perform operating procedure. |

Table 3-43. Switchboard Troubleshooting (Cont).

| MALFUNCTION | TEST OR INSPECTION | | | CORRECTIVE ACTION |
|-----------------------------|---|---|--|-------------------|
| 13. Ground detector lights. | | | | |
| | AO | BO | CO | |
| Normal |  |  |  | Glow |
| Phase A Ground |  |  |  | Bright |
| Phase B Ground |  |  |  | Bright |
| Phase C Ground |  |  |  | Bright |

If light is dark and others are not brightly lit, the light bulb or lamp holder may be loose or defective. Refer to paragraph 3-59.

Table 3-44. 24VDC Rectifier Troubleshooting.

| MALFUNCTION | TEST OR INSPECTION | CORRECTIVE ACTION |
|-------------|--------------------|-------------------|
|-------------|--------------------|-------------------|

WARNING

DEATH or SEVERE INJURY can occur if personnel fail to observe safety precautions. Be sure the circuit breaker to the battery charger is in the OFF position. Tag the circuit breaker to prevent accidental turn on.

- Batteries not charged.
 - Step 1. Check circuit breaker on power distribution panel. Reset.

Table 3-44. 24VDC Rectifier Troubleshooting (Cont).

| MALFUNCTION | TEST OR INSPECTION | CORRECTIVE ACTION |
|----------------------------------|---|-------------------|
| 1. Batteries not charged (Cont). | <p>Step 2. Check incoming power fuses (1).</p> <p>Check with multimeter and replace if defective.</p> <p>Step 3. Check output fuses (2).</p> <p>Check with multimeter and replace if defective.</p> <p>Step 4. Check batteries.</p> <p>Check and clean battery terminals.</p> | |
| 2. Ammeter. | <p>Step 1. Check for broken glass or damaged needle.</p> <p>Replace. Refer to paragraph 3-108.</p> | |

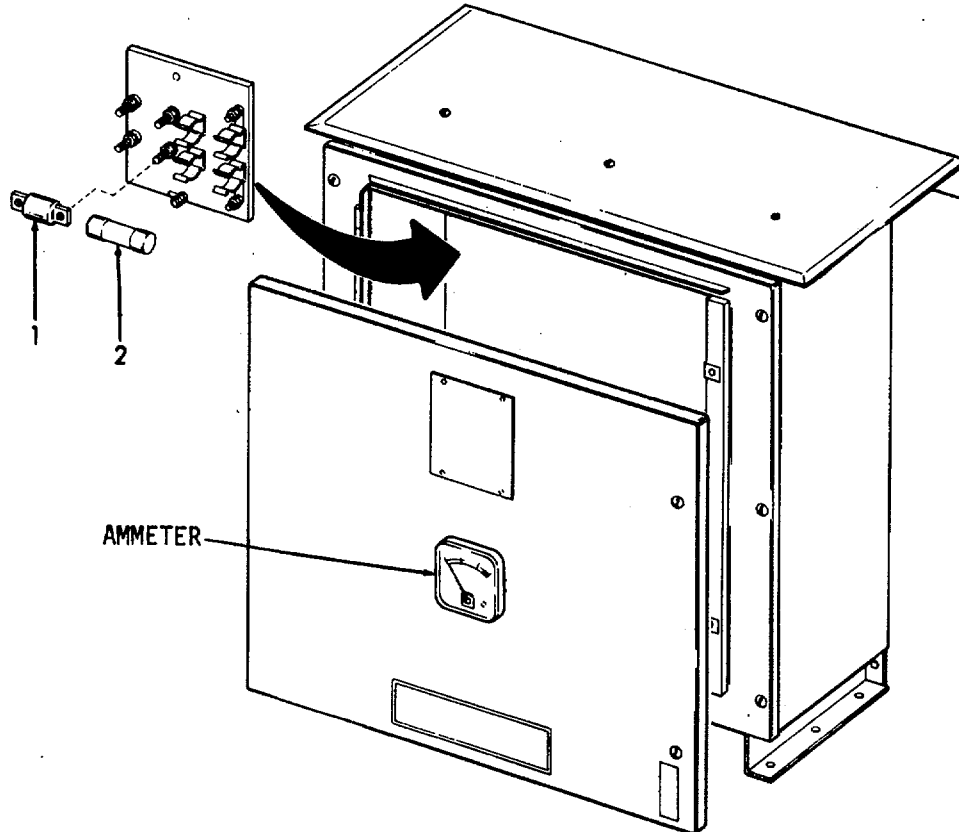

Table 3-45. Bow Ramp Winch Troubleshooting.

| MALFUNCTION | TEST OR INSPECTION | CORRECTIVE ACTION |
|-------------|--------------------|-------------------|
|-------------|--------------------|-------------------|

- 1. Motor does not start.
 - Step 1. Check disconnect switch.
Turn it on.
 - Step 2. Check fuses (1).
Replace if necessary.

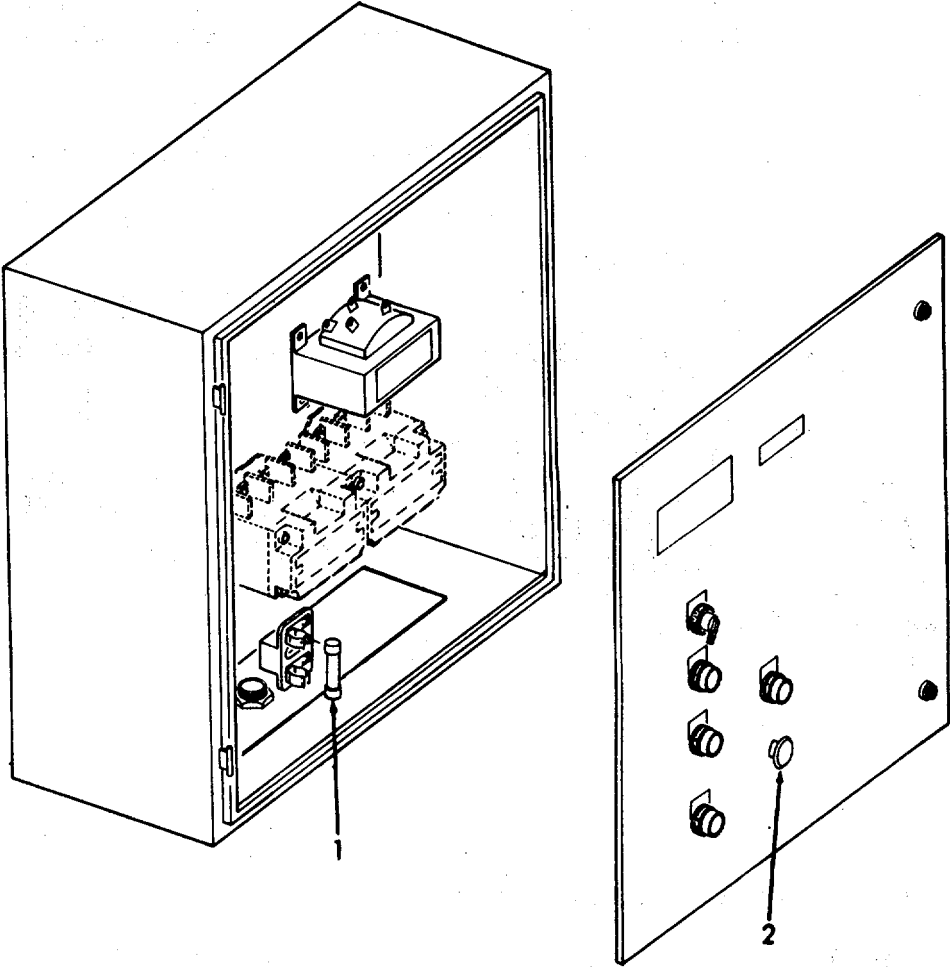

Table 3-45. Bow Ramp Winch Troubleshooting (Cont).

| MALFUNCTION | TEST OR INSPECTION | CORRECTIVE ACTION |
|-------------|--------------------|-------------------|
|-------------|--------------------|-------------------|

1. Motor does not start (Cont).

Step 3. Check motor overloads.

Press reset (2).

If problem continues, refer to Direct Support Maintenance.

Step 4. Check slack cable and hand crank limit switches.

Replace hand operation cover or eliminate slack cable condition. Refer to paragraph 3-122.

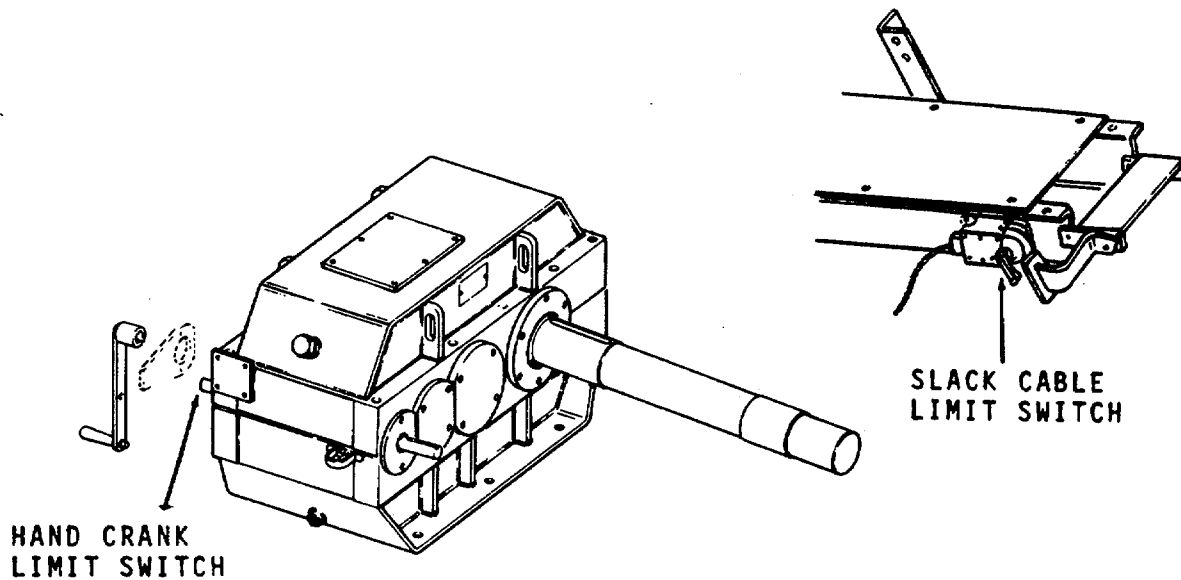

2. Motor runs - shaft does not turn.

Step 1. Check pawl.

Disengage.

Table 3-45. Bow Ramp Winch Troubleshooting (Cont).

| MALFUNCTION | TEST OR INSPECTION | CORRECTIVE ACTION |
|-------------|--------------------|-------------------|
|-------------|--------------------|-------------------|

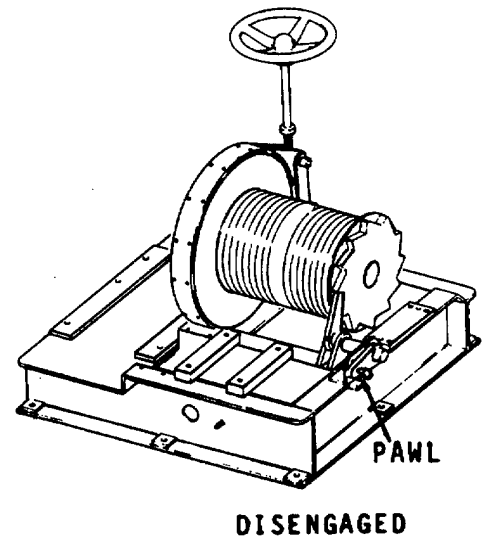
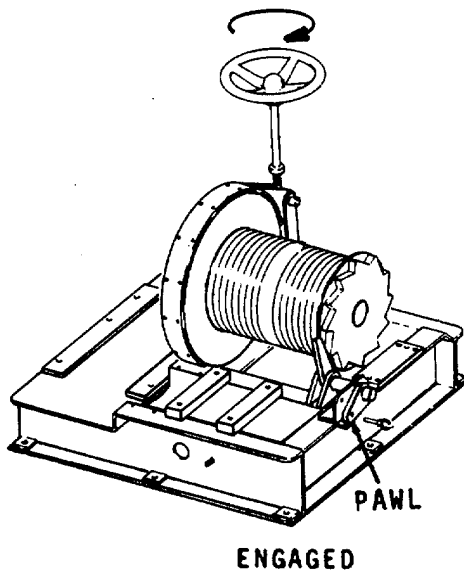

2. Motor runs - shaft does not turn (Cont).

Step 2. Check torque coupling.

Adjust per paragraph 3-118.

Step 3. Motor runs - reducer input shaft turns - output shaft does not turn.

Internal damage in reducer - Refer to paragraph 3-119.

Step 4. Motor runs - reducer output shaft turns - drum does not turn.

Sheared key in drum shaft - remove drum and replace key. Refer to paragraph 3-117.

Table 3-46. Bow Ramp Winch Brake Troubleshooting.

NOTE

Refer to paragraph 3-120 for all maintenance.

| MALFUNCTION | TEST OR INSPECTION | CORRECTIVE ACTION |
|-------------|--------------------|-------------------|
|-------------|--------------------|-------------------|

1. Brake does not release.

Step 1. Check for power failure.
 Check circuit breakers and fuses.

Step 2. Check for broken or damaged parts.
 Replace.

Step 3. Check electrical connections.
 Tighten or replace.

Step 4. Check manual release.
 Check that it is not stuck.

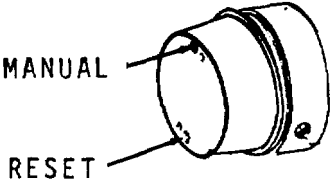

Step 5. Check for damaged pressure plate assembly.
 Replace if magnetic coils are burned or charred.

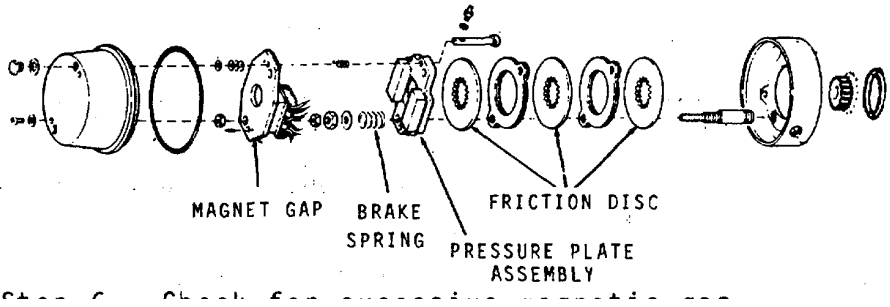

Step 6. Check for excessive magnetic gap.
 Readjust gap [max .065 (0.165 cm) min .035 (0.089 cm)].

Table 3-46. Bow Ramp Winch Brake Troubleshooting (Cont).

NOTE

Refer to paragraph 3-120 for all maintenance.

| MALFUNCTION | TEST OR INSPECTION | CORRECTIVE ACTION |
|----------------------------------|--|---|
| 2. Brake does not stop. | Step 1. Check manual reset. | Place in reset position. |
| | Step 2. Check for broken or worn parts. | Replace. |
| | Step 3. Check for friction disc wear. | Readjust gap. |
| | Step 4. Check for broken friction disc. | Replace. |
| 3. Brake chatters or hums. | Step 1. Check for dirt in magnet faces. | Clean. |
| | Step 2. Check for parallel magnet faces. | Readjust gap [max .065 (0.165 cm) min .035 (0.089 cm)]. |
| | Step 3. Check for low voltage. | Check. |
| 4. Manual release does not work. | Step 1. Check for broken or damaged parts. | Replace. |

Table 3-46. Bow Ramp Winch Brake Troubleshooting (Cont).

NOTE
Refer to paragraph 3-120 for all maintenance.

| MALFUNCTION | TEST OR INSPECTION | CORRECTIVE ACTION |
|--|--------------------|--|
| 4. Manual release does not work (Cont) | Step 2. | Check brake spring. Replace if broken. |
| | Step 3. | Check shim washers. Check that quantity is correct under release stop screws. |
| | Step 4. | Check magnet gap. Readjust. |

Table 3-47. Bow Ramp Winch Motor Troubleshooting.

NOTE
Refer to paragraph 3-120 for all maintenance except as noted.

| MALFUNCTION | TEST OR INSPECTION | CORRECTIVE ACTION |
|--------------------------|--------------------|--|
| 1. Motor does not start. | Step 1. | Check for fuse out, loose or open connection. Correct open circuit condition. |
| | Step 2. | Check rotating parts of motor. They may be jammed mechanically. Check and correct - Bent shaft. Refer to Direct Support Maintenance any broken housing, damaged bearings, or foreign material in motor. |

Table 3-47. Bow Ramp Winch Motor Troubleshooting (Cont).

NOTE

Refer to paragraph 3-120 for all maintenance except as noted.

| MALFUNCTION | TEST OR INSPECTION | CORRECTIVE ACTION |
|--|--------------------|--|
| 1. Motor does not start (Cont). | Step 3. | Check for jammed driven machine. Correct jammed condition. |
| | Step 4. | Check power. Check for voltage at motor and work back to power supply. |
| 2. Motor starts but does not come up to speed. | Step 1. | Check for overload. Press reset. |
| 3. Motor runs hot (exceeds rating). | Step 1. | Check for overload Reduce load. |
| | Step 2. | Check for impaired ventilation. Clean. |
| | Step 3. | Check for frequent starts or stops. Reduce number of starts or reversals. |
| | Step 4. | Check for misalignment between rotor and stator laminations. Realign. |
| 4. Noisy (mechanically). | Step 1. | Inspect for misalignment of coupling or sprocket. Correct misalignment. |

Table 3-47. Bow Ramp Winch Troubleshooting (Cont).

NOTE

Refer to paragraph 3-120 for all maintenance except as noted.

| MALFUNCTION | TEST OR INSPECTION | CORRECTIVE ACTION |
|-------------|--------------------|-------------------|
|-------------|--------------------|-------------------|

- 4. Noisy (mechanically) (Cont).
 - Step 2. Inspect for mechanical unbalance of rotating parts.
Find unbalanced part, then balance.
 - Step 3. Inspect for lack of or improper lubricant.
Use correct lubricant, replace parts as necessary.
 - Step 4. Check for foreign material in lubricant.
Clean out and replace bearings.
 - Step 5. Check for overload.
Remove overload condition. Replace damaged parts.
 - Step 6. Check for dragging rotor due to worn bearings, shaft or bracket.
Replace bearings, shaft or bracket as needed.

Table 3-48. Anchor Winch - Winch Troubleshooting.

NOTE
Refer to figure 3-2 for overall view.

| MALFUNCTION | TEST OR INSPECTION | CORRECTIVE ACTION |
|-------------|--------------------|-------------------|
|-------------|--------------------|-------------------|

- 1. Universal joint assembly - noisy.
 - Step 1. Check for insufficient lubrication.
Lubricate.
 - Step 2. Check for excessive play in shaft and universal.
 - a. Tighten all nuts and bolts.
 - b. Worn bearings in universal joint. Refer to Direct Support Maintenance.

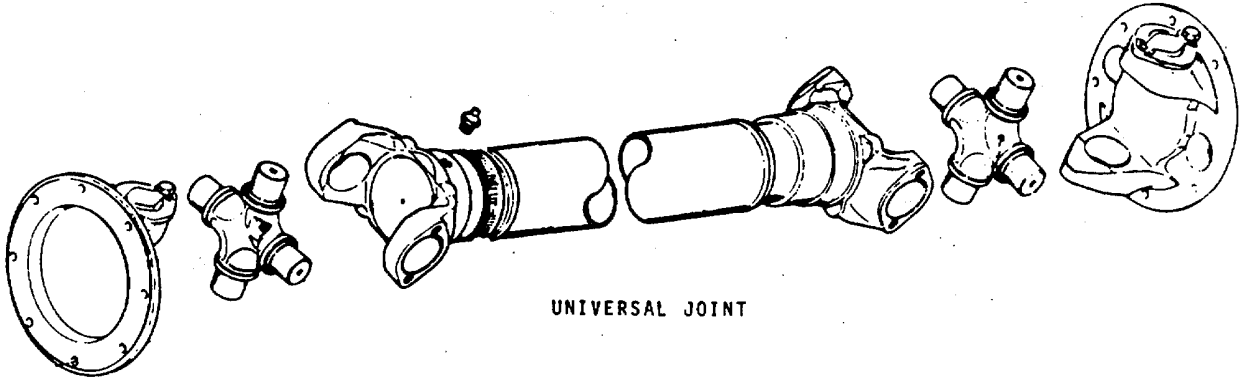

Table 3-48. Anchor Winch - Winch Troubleshooting (Cont).

NOTE
Refer to figure 3-2 for overall view.

| MALFUNCTION | TEST OR INSPECTION | CORRECTIVE ACTION |
|-------------|--------------------|-------------------|
|-------------|--------------------|-------------------|

- | | | |
|----|-------------------------|--|
| 2. | Drive brake - slipping. | |
| | Step 1. | Check brake adjustment. Adjust. Refer to paragraph 3-130. |
| | Step 2. | Inspect for worn brake linings. Replace. Refer to paragraph 3-130. |
| | Step 3. | Check brake control (vehicle deck). a. Clean and lubricate. b. Adjust linkage. Refer to paragraph 3-130. |

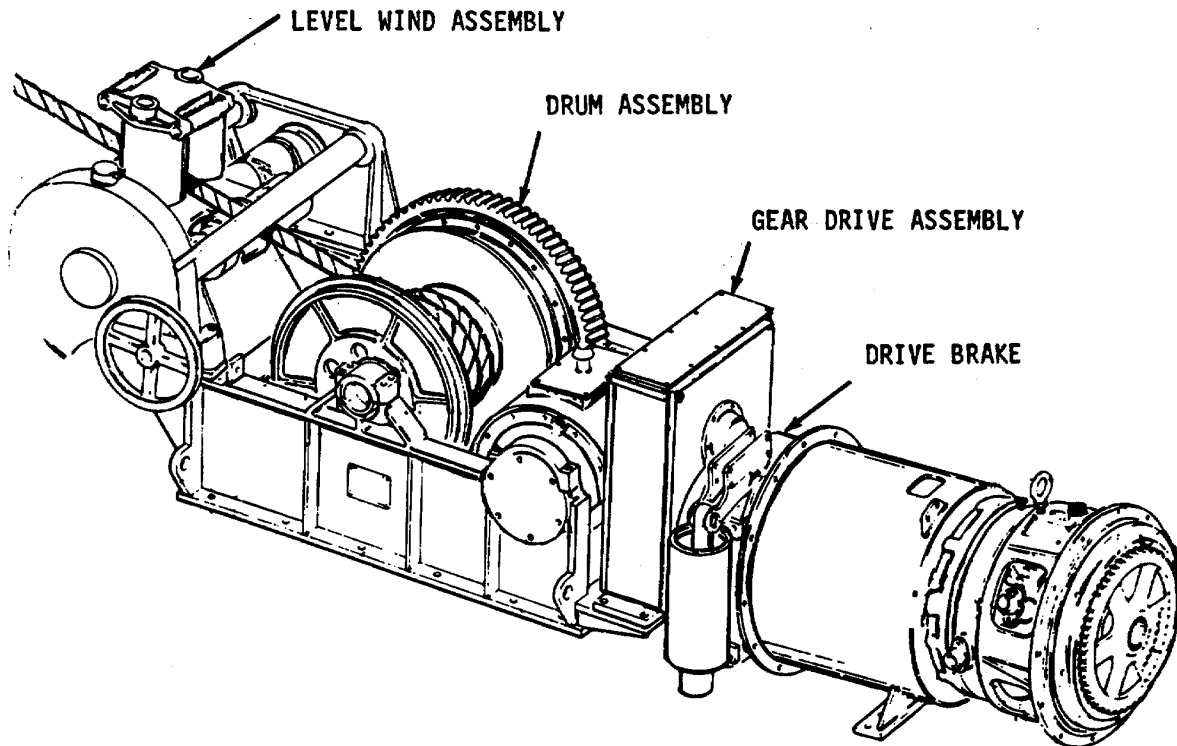

Figure 3-2. Anchor Winch - (Overall view)

Table 3-48. Anchor Winch - Winch Troubleshooting (Cont).

NOTE
Refer to figure 3-2 for overall view.

| MALFUNCTION | TEST OR INSPECTION | CORRECTIVE ACTION |
|-------------|--------------------|-------------------|
|-------------|--------------------|-------------------|

3. Drive gear.

Step 1. Inspect for leaking gaskets and seals.
Replace. Refer to paragraph 3-131.

4. Level wind assembly - noisy.

Step 1. Check lubrication of gears, chain, and fitting.
Lubricate.

Step 2. Inspect for worn chain.
Replace. Refer to paragraph 3-132.

Step 3. Inspect for worn bushings, rollers, and guides.
Replace. Refer to Direct Support Maintenance.

Step 4. Inspect for loose components.
Tighten.

Table 3-49. Anchor Winch Slack Puller Troubleshooting.

| MALFUNCTION | TEST OR INSPECTION | CORRECTIVE ACTION |
|---------------------------|--------------------|--|
| 1. Noisy. | Step 1. | Inspect for loose components. Tighten. |
| | Step 2. | Check bearings and gears. Lubricate. |
| 2. Leaking grease or oil. | Step 1. | Inspect for loose mounting of hydraulic motor. Tighten all connections. |
| | Step 2. | Inspect for loose hydraulic hoses. Tighten all connections. |
| 3. Inoperative. | Step 1. | Inspect for bending of anchor cable. Turn off system and manually adjust cable. |
| | Step 2. | Check for sufficient cable lubrication. Lubricate. |
| | Step 3. | Inspect for defective hydraulic hoses. Replace. Refer to paragraph 3-136. |
| | Step 4. | Check for defective hydraulic motor. Replace. Refer to paragraph 3-134. |

Table 3-49. Anchor Winch Slack Puller Troubleshooting (Cont).

| MALFUNCTION | TEST OR INSPECTION | CORRECTIVE ACTION |
|-------------|--------------------|-------------------|
|-------------|--------------------|-------------------|

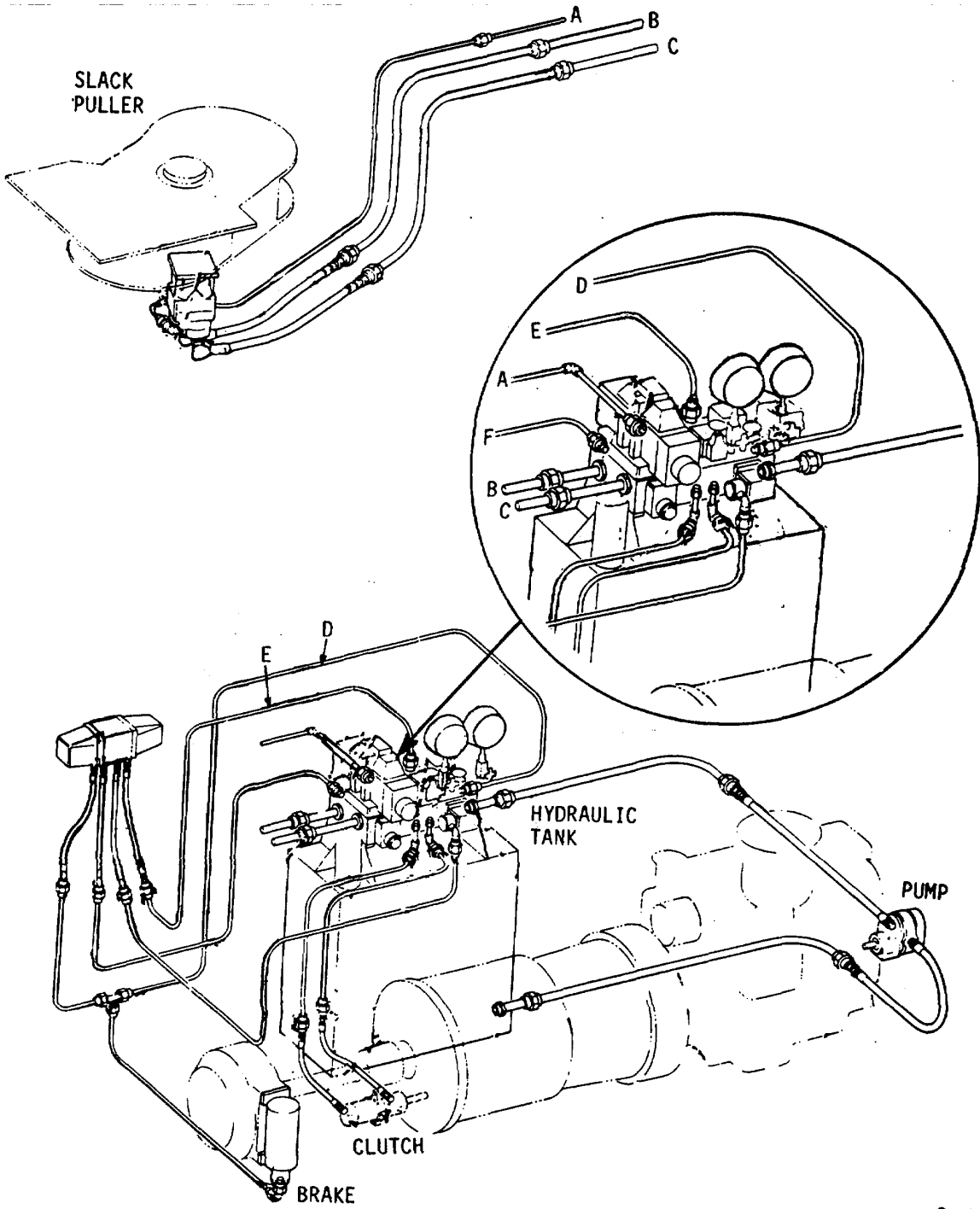
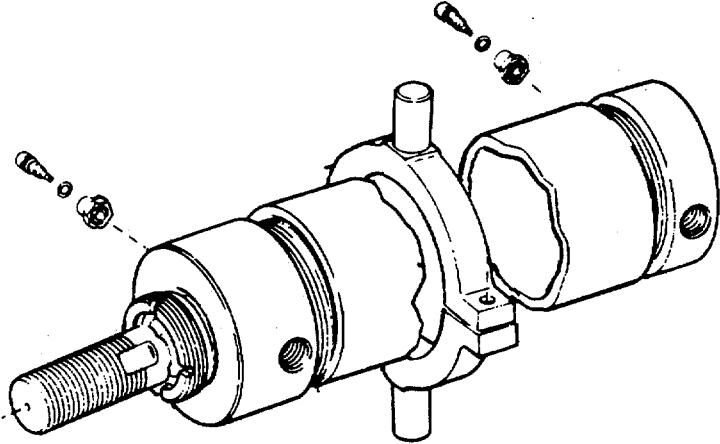

Table 3-50. Anchor Winch Disconnect Clutch Troubleshooting.

| MALFUNCTION | TEST OR INSPECTION | CORRECTIVE ACTION |
|-------------|--------------------|-------------------|
|-------------|--------------------|-------------------|

- 1. Clutch slipping.
 - Step 1. Check for leaking hydraulic cylinder.
Repair. Refer to paragraph 3-135.



- Step 2. Inspect to see if it is out of adjustment.
Adjust. Refer to paragraph 3-135.
 - Step 3. Inspect for internal clutch problems.
Refer to Direct Support Maintenance.

- 2. Clutch binding.
 - Step 1. Check for insufficient lubrication on throwout yoke pin.
Lubricate.

Table 3-51. Anchor Winch Torque Converter Troubleshooting.

NOTE

Refer to paragraph 3-136 for maintenance, unless noted.

| MALFUNCTION | TEST OR INSPECTION | CORRECTIVE ACTION |
|----------------------------------|---|---|
| 1. Loss of fluid from converter. | Step 1. Inspect for leaky pipe connections. | Check all lines and connections. Be sure no rubbing or excessive vibration is present. Have system under pressure when looking for leaks by operating converter at partial speed. |
| | Step 2. Inspect for leaky converter. | Check all bolts and nuts clamping gasketed joints while system is under pressure. |
| | Step 3. Inspect for leakage around output shaft or into lube oil chamber. | This may be caused by a mislocated seal gasket which will not allow the seal drain to function. The fluid drain holes in the seal assembly and seal gasket must line up with the drain hole in the housing. |
| | Step 4. Inspect for leaking fluid into lube oil chamber. | This indicates worn charging pump seal, allowing fluid to leak into the lube oil chamber along the charging pump shaft. |
| | Step 5. Inspect for excessive leakage past seals. | This may be indicated by low oil pressure. |
| | a. Low oil pressure may also indicate that filter is clogged. | Replace filter. |

Table 3-51. Anchor Winch Torque Converter Troubleshooting (Cont).

NOTE

Refer to paragraph 3-136 for maintenance, unless noted.

| MALFUNCTION | TEST OR INSPECTION | CORRECTIVE ACTION |
|-------------|--------------------|-------------------|
|-------------|--------------------|-------------------|

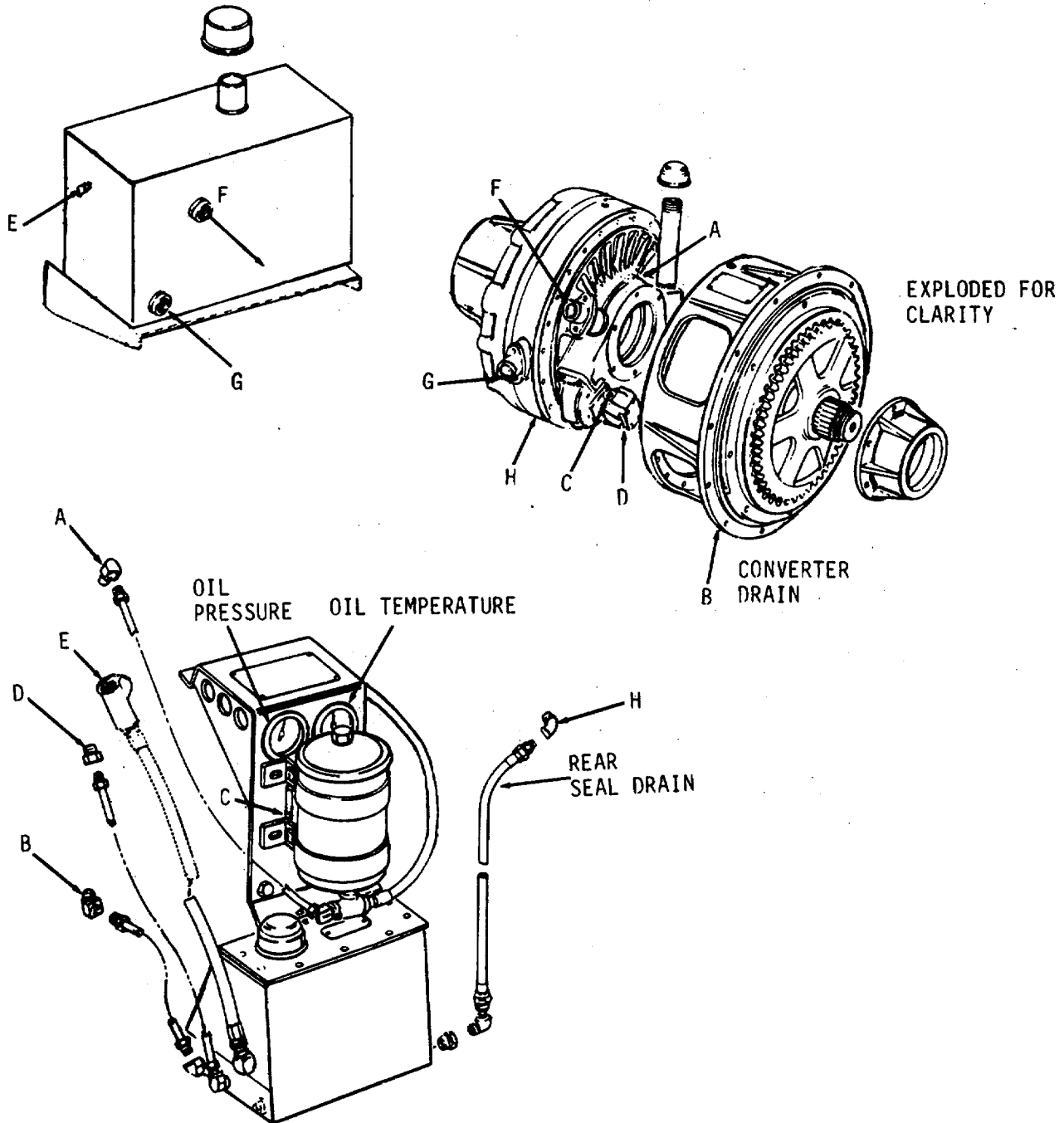

Table 3-51. Anchor Winch Torque Converter

Troubleshooting (Cont).

NOTE

Refer to paragraph 3-136 for maintenance unless otherwise noted.

| MALFUNCTION | TEST OR INSPECTION CORRECTIVE ACTION |
|-------------|---|
|-------------|---|

1. Loss of fluid from converter.

Step 5. b. Low oil pressure may also be caused by converter fluid entering lube oil chamber or by fluid entering turbine bearing chamber. To check fluid leakage, disconnect seal drain lines, then close line so fluid from reserve tank will not escape. With converter operating, observe leakage at seal drain outlet and if excessive (a steady stream), repair.

Refer to Direct Support Maintenance.

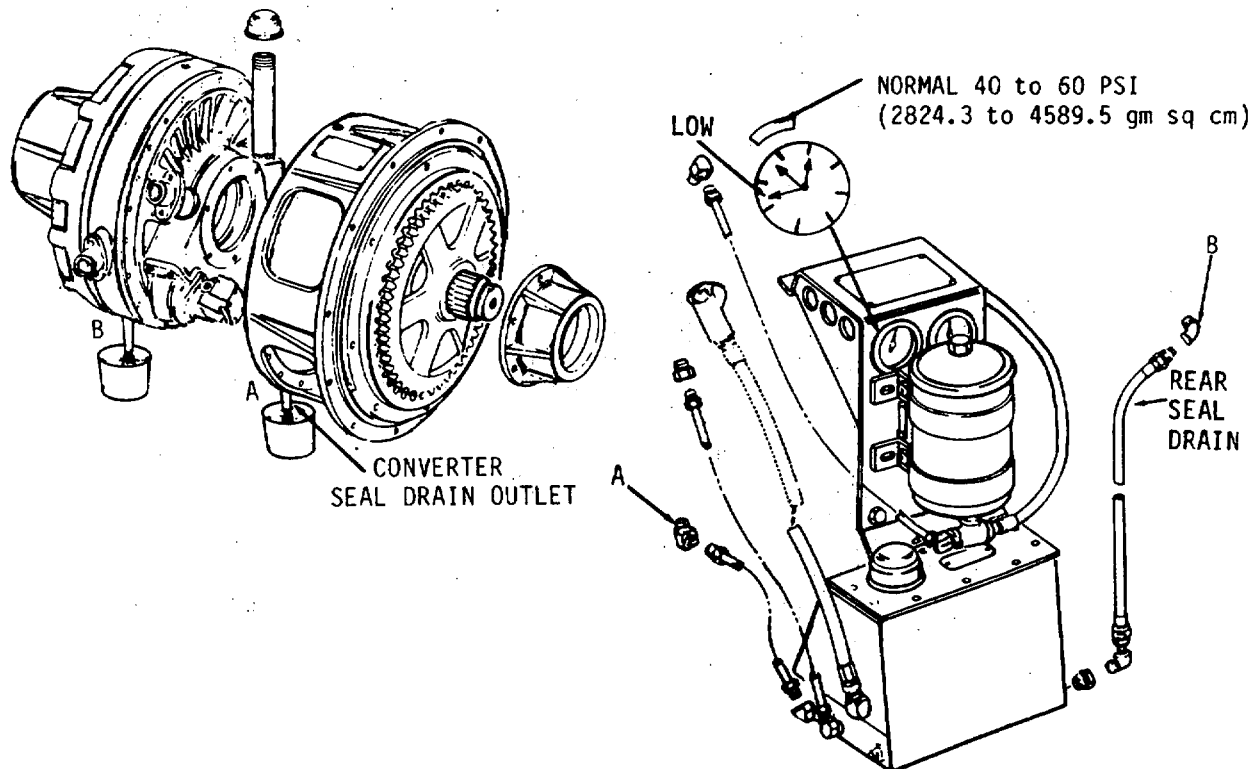

Table 3-51. Anchor Winch Torque Converter
 Troubleshooting (Cont).

NOTE

Refer to paragraph 3-136 for maintenance unless otherwise noted.

| MALFUNCTION | TEST OR INSPECTION | CORRECTIVE ACTION |
|-------------|--------------------|-------------------|
|-------------|--------------------|-------------------|

1. Loss of fluid from converter (Cont)

Step 6. Overflowing reserve tank.

Replace clogged line. Low oil pressure is an indication of the following conditions.

- a. A damaged charging pump, whether operating or not, may permit fluid to flow back to the reserve tank from the converter. When converter is not operating, fluid could leak thru the pump into the reserve tank, since the reserve tank is lower than the converter proper. With the converter operating, but with the pump non-operative, due to damage, fluid could continually be bled into the reserve tank from the reservoir overflowing the same as if the charging pump were not performing its function of delivering fluid from the reserve tank to the converter. Refer to Direct Support Maintenance.

- b. A clogged line (A) from the reserve tank to the pump will not permit the charging pump to pick up fluid, thus causing the tank to overflow. Low gauge-pressure is also an indication of the above conditions.

- c. Check the pressure line (B) from the charging pump through the main fluid filter to the converter. A stop anywhere in this line would result in depriving the converter of its regular constant supply of fluid, while a portion is still bleeding out through the orifice assembly.
 Replace the line.

Table 3-51. Anchor Winch Torque Converter Troubleshooting (Cont).

NOTE

Refer to paragraph 3-136 for maintenance, unless noted.

| MALFUNCTION | TEST OR INSPECTION | CORRECTIVE ACTION |
|-------------|--------------------|-------------------|
|-------------|--------------------|-------------------|

1. Loss of fluid from converter (Cont).

- d. If the line stoppage should exist between the line (C) to the pressure gauge and the torque converter, the pressure reading would be normal, or slightly high, while the actual pressure and fluid supply within the converter would be low.

Replace the lines.

Replace the lines.

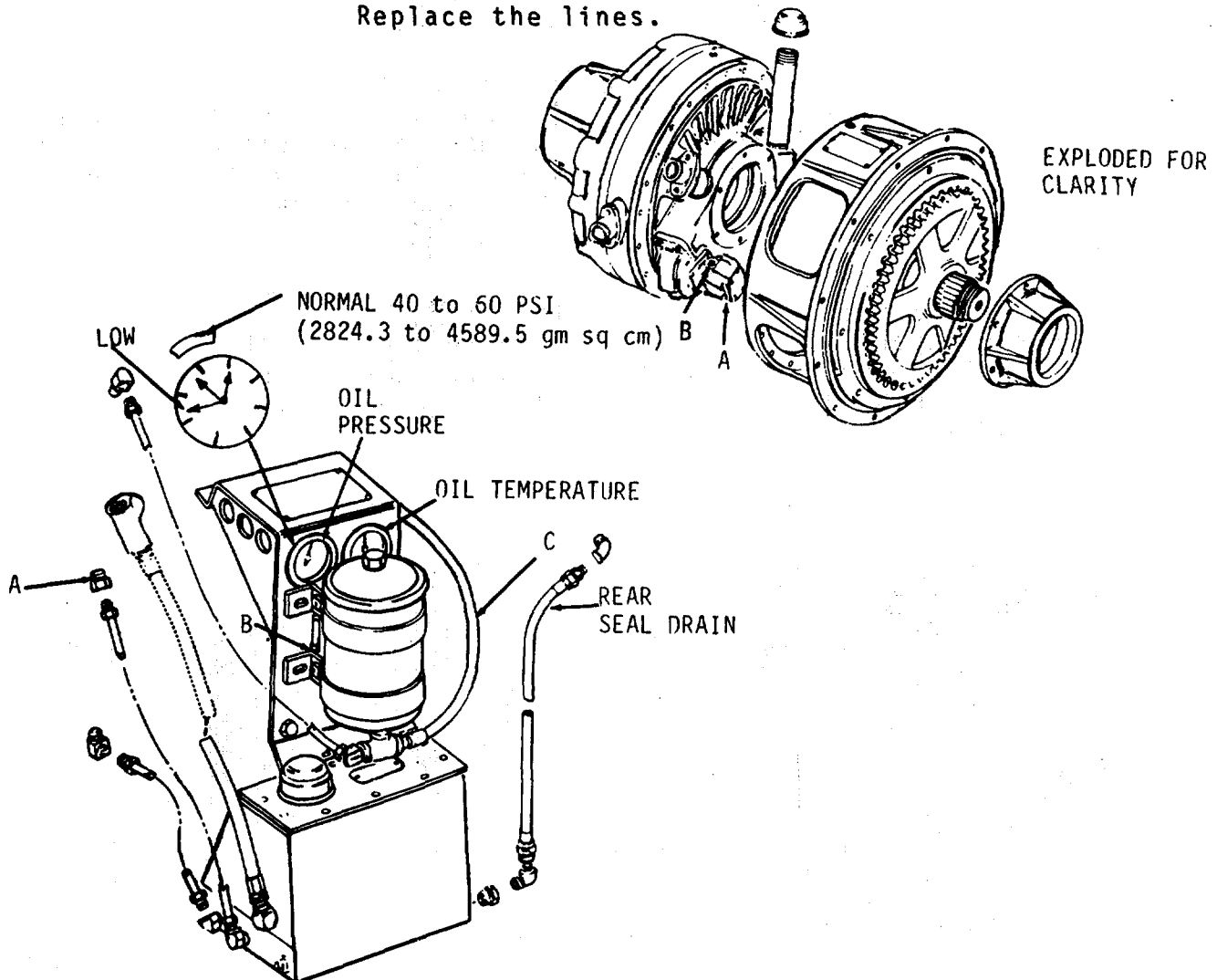

Table 3-51. Anchor Winch Torque Converter Troubleshooting (Cont).

| MALFUNCTION | TEST OR INSPECTION | CORRECTIVE ACTION |
|-------------|--------------------|-------------------|
|-------------|--------------------|-------------------|

2. Poor performance and overheating of converter.

Step 1. Check for air in system.

- a. Low basic pressure, overheating and loss of pulling power are likely indications of air in the system. Partially open the bleed valve at the high point of the fluid system with the unit running. If any air is present, the source of the air leak into the fluid system must be located.
- b. Check the fluid level in the reserve tank to be sure it is not too low.
- c. Make a very close check of all points on the suction line (D) from the reserve tank to the charging pump. It may be possible an air leak exists in this line which may not show up as a fluid leak with the unit shut down.

NOTE

To insure proper bleeding of the fluid system during operation, remove the orifice assembly (E) and clean the filter screen and give particular attention to the orifice hole in the body of the assembly.

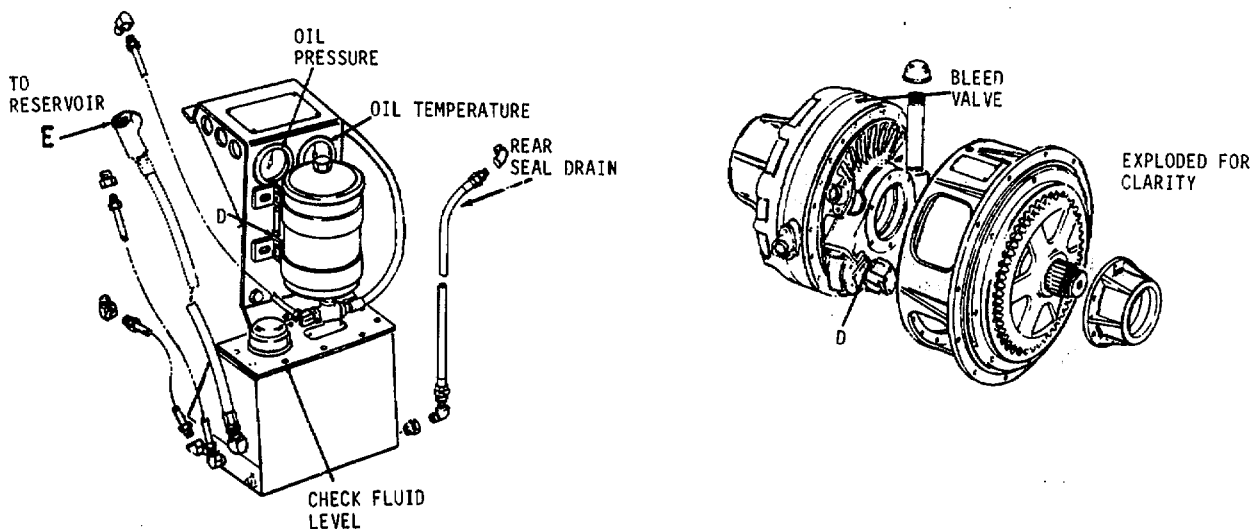

Table 3-51. Anchor Winch Torque Converter Troubleshooting (Cont).

MALFUNCTION

TEST OR INSPECTION

CORRECTIVE ACTION

2. Poor performance and overheating of converter (Cont).

NOTE

Pressure on gauge should be between 45 and 65 PSI (2824.3 to 4589.5 gm sq cm). Stop engine and observe oil pressure gauge hand. If air is present in the converter chamber, the gauge hand will not move immediately to zero, but will hesitate on the downward movement. Also note fluid level in re-serve tank. If air is present in the converter, the fluid level in the reserve tank will rise and may even overflow the tank. (NOTE: If the pressure gauge hand goes right down to zero the instant the converter stops and if the fluid level in the re-serve tank does not rise after stopping the converter, there is no air in the chamber). If air is found to be present in the system after the orifice filter has been cleaned and replaced, the procedure for bleeding the converter explained under malfunction 2, step 1a, above should be followed to eliminate air and gain complete fluid fill.

Step 2. Check for low basic pressure.

This can be checked by direct reading on the pressure gauge. It should read between 45 to 65 PSI (2824.3 to 4589.5 gm sq cm).

- a. Check fluid lines for leaks and restrictions.
- b. Check for clogged filter.
- c. Check seal drains for excessive leakage.
- d. Check the accuracy of the gauge.
- e. Charging pump could be replaced.

Refer to Direct Support Maintenance.

NOTE

If basic pressure is too low, the fluid passing around the blades in the converter housing becomes turbulent and causes an undue loss of efficiency with resultant overheating.

Table 3-51. Anchor Winch Torque Converter Troubleshooting (Cont).

| MALFUNCTION | TEST OR INSPECTION | CORRECTIVE ACTION |
|-------------|---|--|
| 2. | Poor performance and overheating of converter (Cont). | |
| | Step 3. | <p data-bbox="428 415 760 443">Check for adequate cooling.</p> <p data-bbox="428 474 1531 625">A reservoir is used for the direct cooling of the converter fluid, it may become clogged. Wash and blow out with air. The reservoir or heat exchanger tubes may be clogged inside with dirt, rust or extraneous matter, and in such cases must be thoroughly cleaned and flushed out.</p> |
| | Step 4. | <p data-bbox="428 688 776 716">Check if fluid level is too low.</p> <p data-bbox="428 747 1531 842">Check fluid level in reserve tank with engine and converter running. If fluid level is below full mark on dip stick, add enough to bring level up to this mark.</p> <p data-bbox="428 898 1110 926">Refer to MALFUNCTION #1, Loss of fluid from converter.</p> |
| | Step 5. | <p data-bbox="428 961 927 989">Operating too long in low efficiency range.</p> <p data-bbox="428 1020 1531 1293">The cooling reservoir has capacity to adequately cool the converter when operating above 70% efficiency, however, when the output shaft speed is pulled down below a predetermined point or goes above another point and the engine throttle is still wide open, so that the output horsepower becomes less than 70% of the input horsepower, the cooling capacity of the reservoir is exceeded.</p> <p data-bbox="428 1360 1531 1570">The converter will always overheat when the engine throttle is wide open and there is no load on the output shaft to pull the speed down. This is caused by the engine delivering full horsepower to the converter and no horsepower being transmitted out of the converter, resulting in full engine horsepower being transformed into heat in the converter.</p> |

Table 3-51. Anchor Winch Torque Converter Troubleshooting (Cont).

| MALFUNCTION | TEST OR INSPECTION | CORRECTIVE ACTION |
|-------------|--------------------|-------------------|
|-------------|--------------------|-------------------|

3. Low output horsepower.

Step 1. Check if engine is not coming up to rated performance.

Lock winch brake so that output shaft of converter is stalled and will remain stalled when engine throttle is opened wide. With the engine throttle wide open and the converter shaft stalled, measure the engine rpm by the use of a tachometer. If the engine does not climb up to a predetermined speed, it is not developing its full rated horsepower and should be thoroughly checked.

Step 2. Inspect for improper fluid in converter.

Fluid should be:

OIL TYPES

| | | |
|--------------|-----------------|-----------------|
| Above + 32°F | +40°F to - 10°F | 0°F to - 65°F |
| Above 0°C | +5°F to - 23°F | -18°C to - 54°C |
| OE/HDO 30 | OE/HDO 10 | OES |

A thicker fluid will cause loss of efficiency and output horsepower because it does not flow through the blading as readily as the recommended fluid.

Step 3. Check for air in system.

Use procedure listed in MALFUNCTION #2, Step 1.

Step 4. Check for low basic pressure.

Use procedure listed in MALFUNCTION #2, Step 2.

Table 3-51. Anchor Winch Torque Converter Troubleshooting (Cont).

| MALFUNCTION | TEST OR INSPECTION | CORRECTIVE ACTION |
|-------------|--------------------|-------------------|
|-------------|--------------------|-------------------|

4. Excessive pressure.

Step 1. Inspect for stuck piston in relief valve of charging pump.

Refer to Direct Support Maintenance.

NOTE

The pressure and temperature gauges provide the operator with a constant check on converter operation. Immediate recognition of an abnormal reading may prevent a breakdown. It is important, therefore, whenever a gauge is found to be faulty it be immediately replaced.

Table 3-52. Anchor Winch - Hydraulic Tank Balanced

Piston Relief Valves Troubleshooting.

NOTE

Refer to paragraph 3-137 for all maintenance procedures.

| MALFUNCTION | TEST OR INSPECTION | CORRECTIVE ACTION |
|-------------|--------------------|-------------------|
|-------------|--------------------|-------------------|

1. Erratic Pressure.

Step 1. Check for foreign matter in system.

Drain, flush and refill system with clean fluid.

Step 2. Inspect for a worn piston or seat in cover.

Replace piston and seat.

Step 3. Inspect for piston sticking in body or cover.

Clean piston. Remove burrs by light lapping. Check freedom of movement on reassembly.

Replace if necessary.

Table 3-52. Anchor Winch - Hydraulic Tank Balanced

Piston Relief Valves Troubleshooting (Cont).

NOTE

Refer to paragraph 3-137 for all maintenance procedures.

MALFUNCTION

TEST OR INSPECTION

CORRECTIVE ACTION

- | | |
|----|---|
| 2. | <p>Low pressure or no pressure.</p> <p>Step 1. Check for valve being improperly adjusted.</p> <p style="padding-left: 40px;">Adjust valve to proper setting.</p> <p>Step 2. Check if vent connection open.</p> <p style="padding-left: 40px;">Plug vent connection.</p> <p>Step 3. Check for plugged balance hole in piston.</p> <p style="padding-left: 40px;">Remove piston and clean out. If necessary, drain system and refill with clean fluid.</p> <p>Step 4. Inspect for piston in cover not seating.</p> <p style="padding-left: 40px;">Back off adjusting screw several turns while running pump to be certain foreign matter is not caught on the seat. Check condition of seat, spring and piston if malfunction persists.</p> |
| 3. | <p>Excessive noise or chatter.</p> <p>Step 1. Check for high oil velocity through valve.</p> <p style="padding-left: 40px;">Check system.</p> <p>Step 2. Inspect for distorted control spring.</p> <p style="padding-left: 40px;">Replace spring.</p> <p>Step 3. Inspect for worn piston or seat in cover.</p> <p style="padding-left: 40px;">Replace piston and seat.</p> <p>Step 4. Check for valve setting too close to that of system operating pressure.</p> <p style="padding-left: 40px;">Set relief valve at least 150 psi (1034 kpa) higher than other valves in circuit .</p> |

Table 3-53. Anchor Winch - Hydraulic Tank Check

Valves Troubleshooting.

NOTE

Refer to paragraph 3-137 for all maintenance procedures.

| MALFUNCTION | TEST OR INSPECTION | CORRECTIVE ACTION |
|--------------------------------|--------------------|--|
| 1. Erratic Operation. | Step 1. | Check for foreign matter in system. Drain, flush and refill system with clean fluid. |
| | Step 2. | Inspect for worn piston or seat. Replace piston or seat. |
| | Step 3. | Inspect for sticking piston. Clean piston. Remove burrs by light lapping. Check freedom of movement on reassembly. Replace if necessary. |
| 2. Excessive noise or chatter. | Step 1. | Inspect for high oil velocity in valve. Check system. |
| | Step 2. | Inspect for distorted control spring. Replace spring. |
| | Step 3. | Inspect for worn piston or seat. Replace piston and seat. |

Table 3-54. Anchor Winch - Hydraulic Tank Pressure

Control Valves Troubleshooting.

NOTE

Refer to paragraph 3-137 for all maintenance procedures.

| MALFUNCTION | TEST OR INSPECTION | CORRECTIVE ACTION |
|---------------------------------|--------------------|---|
| 1. Erratic Pressure. | Step 1. | Inspect for foreign matter in system. Drain, flush and refill system with clean fluid. |
| | Step 2. | Inspect for worn spool or plunger. Replace spool and plunger. |
| | Step 3. | Check plunger or spool for sticking in body or cover. Clean. Remove burrs by light lapping. Check freedom of movement on reassembly. Replace if necessary. |
| 2. Low pressure or no pressure. | Step 1. | Check for improperly adjusted valve. Adjust valve to proper setting. |
| | Step 2. | Check for spool not seating. Back off adjusting screw several turns while running pump to be certain foreign matter is not caught on the seat. Check condition of covers, spring spool, spring plug, and plunger, if malfunction persists. |
| 3. Excessive noise or chatter. | Step 1. | Check for high oil velocity through valve. Check system. |
| | Step 2. | Inspect for distorted control spring. Replace spring. |

Table 3-54. Anchor Winch Hydraulic Tank Pressure
Control Valves Troubleshooting (Cont).

| MALFUNCTION | TEST OR INSPECTION | CORRECTIVE ACTION |
|---------------------------------------|--------------------|---|
| 3. Excessive noise or chatter (Cont). | Step 3. | Inspect for worn spool or plunger. Replace spool or plunger. |
| | Step 4. | Check that valve setting is too close to that of system operating pressure. Set to operate at 1000 psi (6895 kpa). |

Table 3-55. Anchor Winch Hydraulic Tank Pressure
Reducing Valves Troubleshooting.

NOTE

Refer to paragraph 3-124 for all maintenance procedures.

| MALFUNCTION | TEST OR INSPECTION | CORRECTIVE ACTION |
|----------------------|--------------------|---|
| 1. Erratic Pressure. | Step 1. | Check for foreign matter in system. Drain, flush and refill system with clean fluid. |
| | Step 2. | Inspect for worn piston or seat in cover. Replace piston and seat. |
| | Step 3. | Check piston for sticking in cover. Clean piston. Remove burrs by light lapping. Check freedom of movement on reassembly. Replace if necessary. |

Table 3-55. Anchor Winch Hydraulic Tank Pressure

Reducing Valves Troubleshooting (Cont).

NOTE

Refer to paragraph 3-124 for all maintenance procedures.

| MALFUNCTION | TEST OR INSPECTION | CORRECTIVE ACTION |
|----------------------------------|--------------------|--|
| 1. Erratic Pressure (Cont). | Step 4. | <p>Check for valve sticking in body.</p> <p>Clean valve. Remove burrs by light lapping. Check freedom of movement of reassembly.</p> <p>Replace if necessary.</p> |
| 2. High pressure or no pressure. | Step 1. | <p>Check for valve improperly adjusted.</p> <p>Adjust valve to proper setting.</p> |
| | Step 2. | <p>Check for piston in cover not seating.</p> <p>Back off adjusting screw several turns while running pump to be certain foreign matter is not caught on the seat. Check condition of seat, spring and piston if malfunction persists.</p> |
| 3. Excessive noise or chatter. | Step 1. | <p>Check for low oil velocity through valve.</p> <p>Check system.</p> |
| | Step 2. | <p>Inspect for distorted springs.</p> <p>Replace springs.</p> |
| | Step 3. | <p>Check for worn piston or seat in cover.</p> <p>Replace piston and seat.</p> |
| | Step 4. | <p>Check for valve setting too close to that of system operating pressure.</p> <p>Set to operate at 100.0 psi (6895 kpa).</p> |

Table 3-56. Anchor Winch Hydraulic Tank Directional
Control Valve Troubleshooting.

NOTE

Refer to paragraph 3-137 for all maintenance procedures.

| MALFUNCTION | TEST OR INSPECTION | CORRECTIVE ACTION |
|---------------------------------|--------------------|---|
| 1. Erratic Pressure. | Step 1. | Check for foreign matter in system. Drain, flush and refill system with clean fluid. |
| | Step 2. | Inspect for worn spool or cover(s). Replace spool or cover(s). |
| | Step 3. | Check for spool sticking in body or cover. Clean spool. Remove burrs by light lapping. Check freedom of movement on reassembly. Replace if necessary. |
| 2. Low pressure or no pressure. | | Check that balance hole in spool plugged. Remove spool and clean out. If necessary, drain system and refill with clean fluid. |
| 3. Excessive noise or chatter. | Step 1. | Check for high oil velocity through valve. Check system. |
| | Step 2. | Check for distorted spring. Replace spring. |
| | Step 3. | Inspect for worn spool or cover(s). Replace spool or cover(s). |

Table 3-57. Anchor Winch Hydraulic Tank Troubleshooting.

NOTE

Refer to paragraph 3-137 for all maintenance procedures.

| MALFUNCTION | TEST OR INSPECTION | CORRECTIVE ACTION |
|-------------|---|--|
| 1. | Loss of fluid from hydraulic tank assembly. | <p data-bbox="289 533 837 560">Step 1. Inspect for leaky pipe connections.</p> <p data-bbox="428 596 1511 684">Check all lines and connections. Be sure no rubbing or excessive vibration is present. Have system under pressure when looking for leaks.</p> <p data-bbox="289 720 678 747">Step 2. Check for leaky tank.</p> <p data-bbox="428 783 1284 810">Check all bolts clamping gasketed cover while system is under pressure.</p> <p data-bbox="289 846 1528 873">Step 3. Check for excessive leakage in gaskets. This may be indicated by low pressure on gages.</p> <p data-bbox="428 909 984 936">Low pressure may indicate the filter is clogged.</p> <p data-bbox="428 972 594 999">Replace filter.</p> |
| 2. | Poor performance. | <p data-bbox="289 1089 708 1117">Step 1. Check for dirty air filter.</p> <p data-bbox="428 1152 659 1180">Remove and clean.</p> <p data-bbox="289 1215 708 1243">Step 2. Check for dirty strainer.</p> <p data-bbox="428 1278 659 1306">Remove and clean.</p> <p data-bbox="289 1341 708 1369">Step 3. Check for low pressure.</p> <p data-bbox="428 1404 837 1432">a. Check the gauges for damage.</p> <p data-bbox="428 1467 529 1495">Replace.</p> <p data-bbox="428 1530 649 1558">b. Gauge valves.</p> <p data-bbox="428 1593 636 1621">Clean and adjust.</p> |

Table 3-57. Anchor Winch Hydraulic Tank Troubleshooting (Cont).

NOTE

Refer to paragraph 3-137 for all maintenance procedures.

| MALFUNCTION | TEST OR INSPECTION | CORRECTIVE ACTION |
|-------------|--------------------------|--|
| 2. | Poor performance (Cont). | |
| | Step 3. | c. Fluid lines. Check for damage and clogged lines. d. Hydraulic pump defective. Refer to table 3-55. |
| | Step 4. | Check that fluid level is too low. Check fluid level in tank with engine running, by observing sight gage on side of tank. Add oil as required. |

Table 3-58. Anchor Winch Hydraulic Pump Troubleshooting.

NOTE

Refer to paragraph 3-137 for all maintenance procedures.

| MALFUNCTION | TEST OR INSPECTION | CORRECTIVE ACTION |
|-----------------------------|--------------------|---|
| 1. Loss of fluid from pump. | Step 1. | Inspect for leaky pipe connections. Check all lines and connections. Be sure no rubbing or excess vibration is present. Have system under pressure when looking for leaks. |
| | Step 2. | Inspect for leaking gaskets. Check all bolts clamping gasketed cover while system is under pressure. |
| 2. Lack of pressure. | Step 1. | Check to see pump speed is not same as engine. Check key in shaft. |
| | Step 2. | Check for dirt inside pump. a. Check filter on hydraulic tank. b. Drain oil, disassemble pump and clean. |
| | Step 3. | Inspect for defective drive gears. Replace. |

Table 3-59. Anchor Winch Engine Exhaust Smoke

Analysis Troubleshooting.

MALFUNCTION**TEST OR INSPECTION****CORRECTIVE ACTION**

1. Black or gray smoke.

Step 1. High exhaust back pressure is caused by faulty exhaust piping or muffler obstruction. Remove air box covers.

Clean ports in cylinder liner. Refer to Direct Support Maintenance.

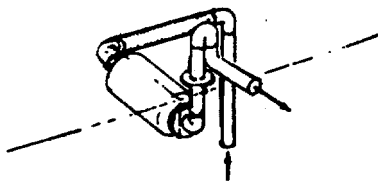

Table 3-59. Anchor Winch Engine Exhaust Smoke

Analysis Troubleshooting (Cont).

| MALFUNCTION | TEST OR INSPECTION | CORRECTIVE ACTION |
|-------------|--------------------|-------------------|
|-------------|--------------------|-------------------|

1. Black or gray smoke (Cont).
 - Step 2. Check for restricted air inlet to the engine cylinders.

Refer to paragraph 3-158.

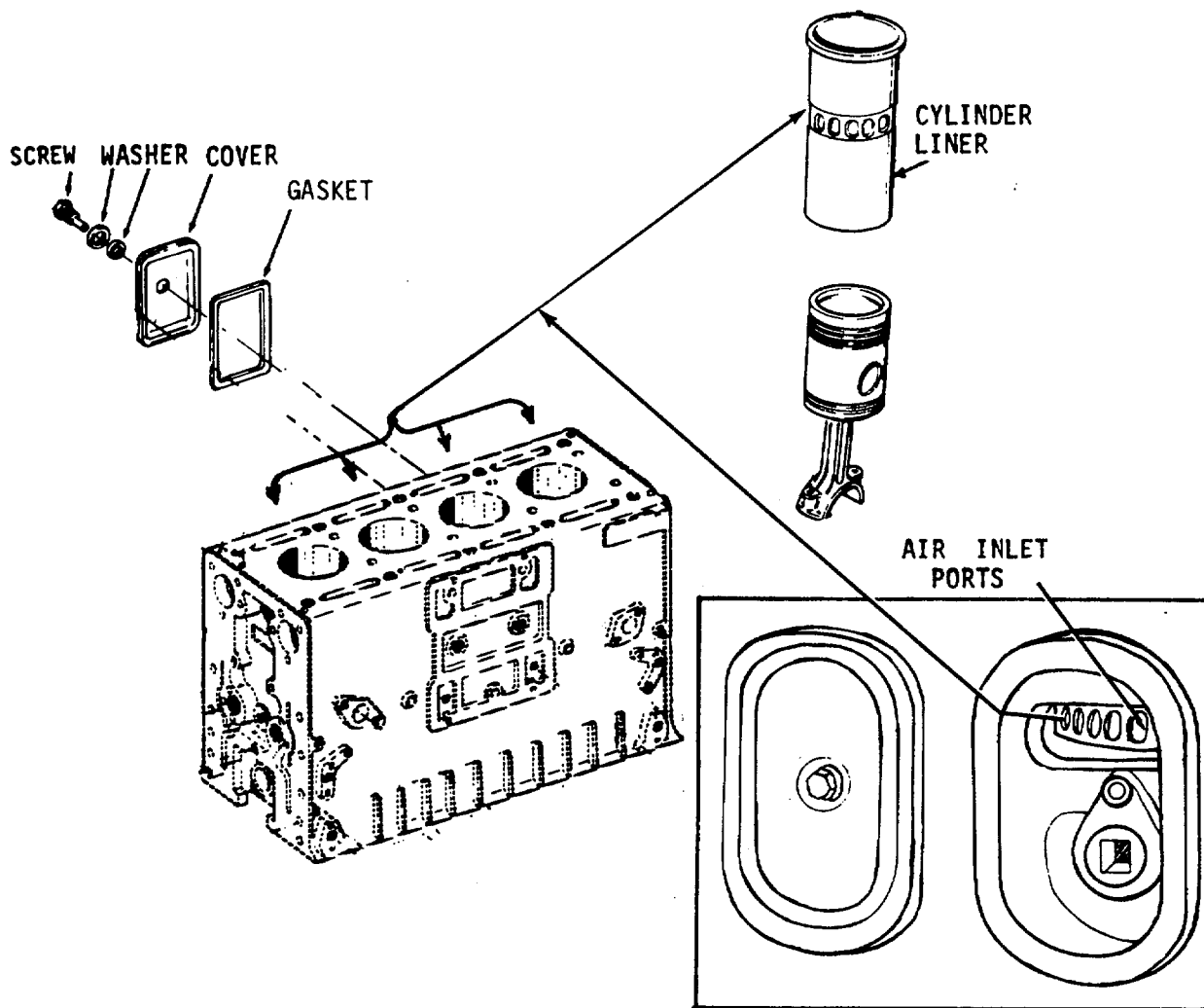

Table 3-59. Anchor Winch Engine Exhaust Smoke

Analysis Troubleshooting (Cont).

| MALFUNCTION | TEST OR INSPECTION | CORRECTIVE ACTION |
|-------------|--------------------|-------------------|
|-------------|--------------------|-------------------|

1. Black or gray smoke (Cont)

Step 3. Check air cleaner or blower air inlet screen.

Clean. Refer to paragraph 3-143.

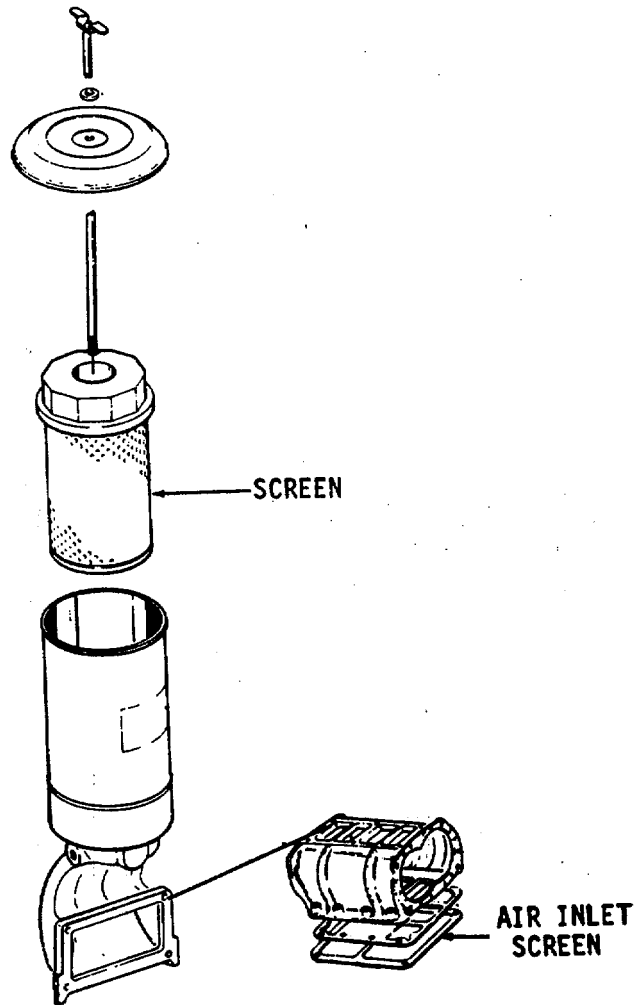

Table 3-59. Anchor Winch Engine Exhaust Smoke

Analysis Troubleshooting (Cont).

| MALFUNCTION | TEST OR INSPECTION | CORRECTIVE ACTION |
|-------------|--------------------|-------------------|
|-------------|--------------------|-------------------|

1. Black or grey smoke (Cont).

Step 4. Check the emergency stop to make sure that it is completely open.

Readjust it if necessary.

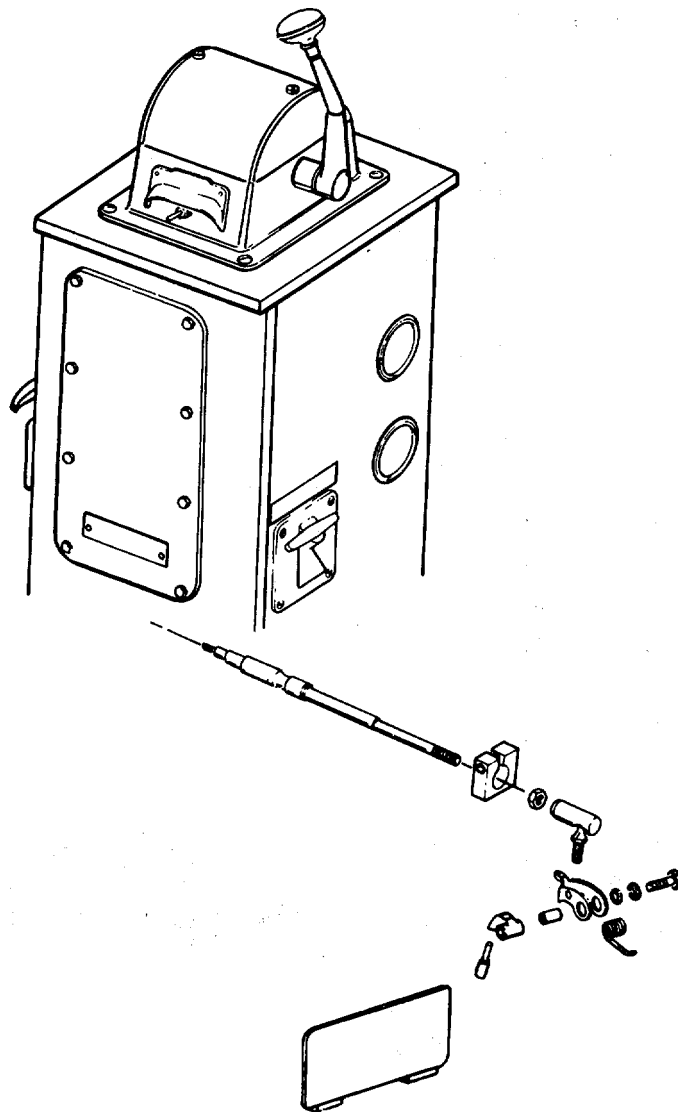

Table 3-59. Anchor Winch Engine Exhaust Smoke

Analysis Troubleshooting (Cont).

| MALFUNCTION | TEST OR INSPECTION | CORRECTIVE ACTION |
|-------------|--------------------|-------------------|
|-------------|--------------------|-------------------|

2. Black or gray smoke caused by excessive fuel or irregular fuel distribution.

Step 1. Check for improperly timed injectors and improperly positioned injector rack control levers.

Time the fuel injectors. Refer to paragraph 3-161.

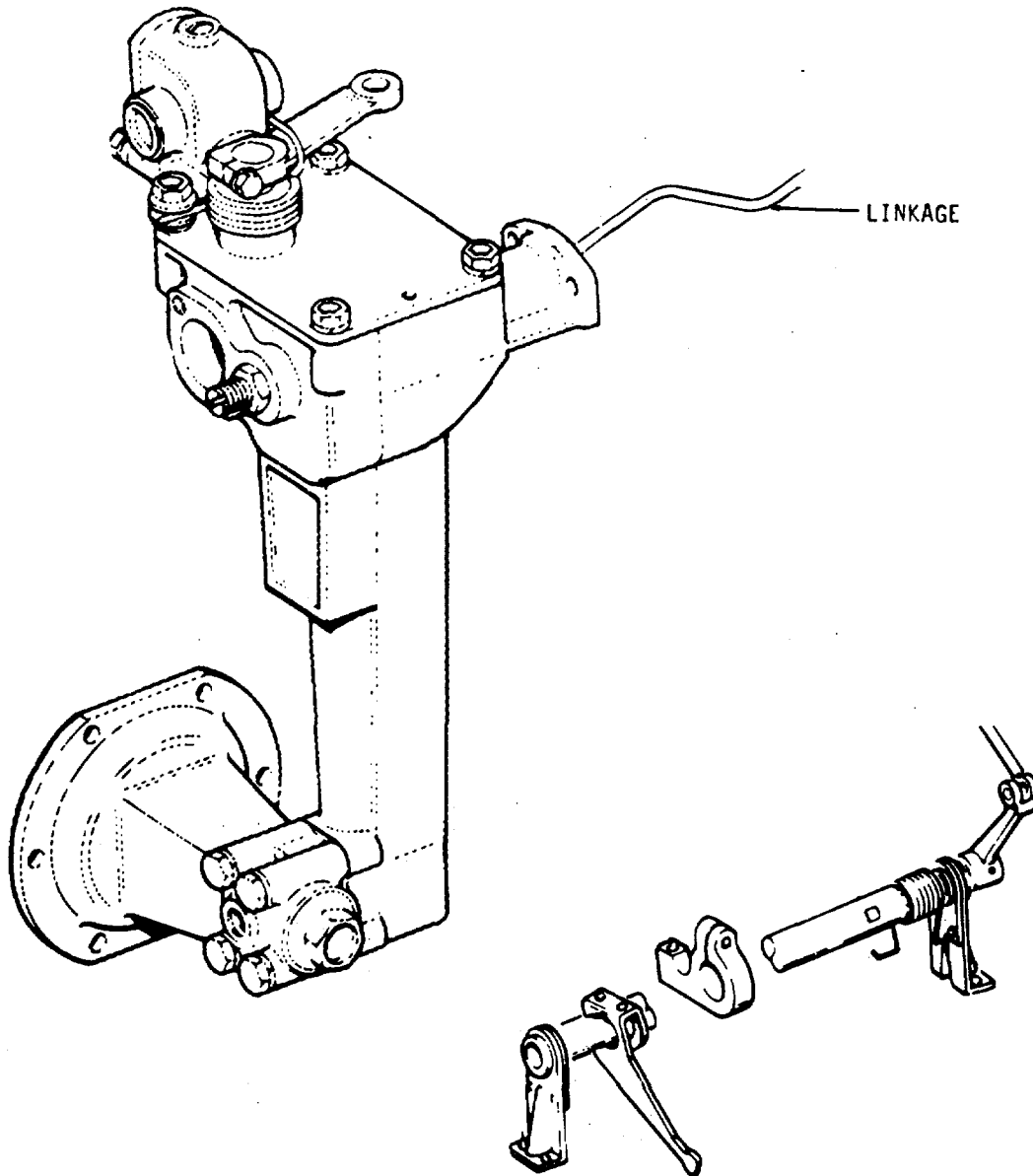

Table 3-59. Anchor Winch Engine Exhaust Smoke
Analysis Troubleshooting (Cont).

| MALFUNCTION | TEST OR INSPECTION | CORRECTIVE ACTION |
|-------------|--------------------|-------------------|
|-------------|--------------------|-------------------|

2. Black or gray smoke caused by excessive fuel or irregular fuel distribution (Cont),
 Step 2. If this condition still persists after timing the injectors. Replace faulty injectors. Refer to paragraph 3-147.

NOTE

Avoid lugging the engine as this will cause incomplete combustion. If problem remains refer to Direct Support Maintenance.

3. Black Improper grade of fuel.
 Check for use of an improper grade of fuel
 Use the Proper Grade of Fuel

DIESEL FUEL

| TYPE | NATIONAL STOCK NUMBER |
|----------------|-----------------------|
| ARTIC (DF-A) | 9140-00-286-5283 |
| WINTER (DF-W) | 9140-00-286-5286 |
| REGULAR (DF-2) | 9140-00-286-5294 |

4. Blue smoke.
 Refer to the High Lubricating Oil Consumption Table 3-63. Lubricating oil not burned in cylinder (blown through cylinder during scavenging period).
 Check for internal lubricating oil leaks.

5. White smoke.
 Step 1. Check for faulty injectors.
 Replace as necessary.
 Step 2. Check for low compression.
 Consult the Hard Starting table 3-60.

Table 3-60. Anchor Winch Engine - Hard Starting Troubleshooting.

| MALFUNCTION | TEST OR INSPECTION | CORRECTIVE ACTION |
|-------------|--------------------|-------------------|
|-------------|--------------------|-------------------|

1. Engine will not rotate.
 - Step 1. Check hydrostarter.
Refer to tables 3-67 thru 3-77, and perform the operations listed.
 - Step 2. Check for defective starting motor switch.
Replace the starting motor switch at the control station. Refer to paragraph 3-138.
 - Step 3. Check for internal seizure.
Hand crank the engine at least one complete revolution. If the engine cannot be rotated a complete revolution, internal damage is indicated and the engine must be disassembled to ascertain the extent of damage and the cause. Refer to paragraph 3-140.

2. Low cranking speed.
 - Step 1. Inspect for improper lubricating oil viscosity.

LUBRICATING OIL GRADES

| DESCRIPTION | SPECIFICATION |
|----------------|---------------|
| OES (Sub Zero) | MIL-L-10295 |
| OE/HDO - 10 | MIL-L-2104 |
| OE/HDO - 20 | MIL-L-2104 |
| OE/HDO - 30 | MIL-L-2104 |

NOTE

At low ambient temperatures, use of a starting aid will reduce the cranking time.

Table 3-60. Anchor Winch Engine - Hard Starting
 Troubleshooting (Cont).

| MALFUNCTION | TEST OR INSPECTION | CORRECTIVE ACTION |
|-------------------------------|--------------------|--|
| 2. Low cranking speed (Cont). | Step 2. | Check for loose hydrostarter connections or faulty starter. Tighten the starter connections Refer to tables 3-72 thru 3-77 for hydrostarter problems. |
| 3. No fuel. | Step 1. | Check for air leaks, flow obstruction, faulty fuel pump, and faulty installation. To check for air leaks, flow obstruction, faulty fuel pump or faulty installation, consult the No Fuel or Insufficient Fuel table 3-62. |
| | Step 2. | Check for injector racks not in full-fuel position. Check for bind in the governor-to-injector linkage. Readjust the governor and injector controls if necessary. Refer to paragraph 3-142 and 3-161. |

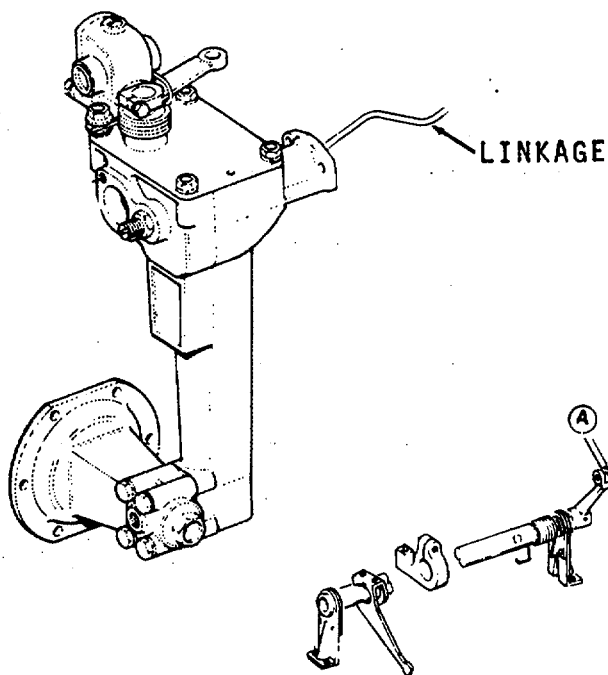

Table 3-60. Anchor Winch Engine - Hard Starting

Troubleshooting (Cont).

| MALFUNCTION | TEST OR INSPECTION | CORRECTIVE ACTION |
|-------------|--------------------|-------------------|
|-------------|--------------------|-------------------|

4. Low compression.

Step 1. Check for exhaust valves that are sticking or burned.

Remove the cylinder head and recondition the exhaust valves. Refer to paragraph 3-163.

Step 2. Check for compression rings that are worn or broken.

Remove the air box covers and inspect the compression rings through the ports in the cylinder liners. Overhaul the cylinder assemblies if the rings are badly worn or broken. Refer to paragraph 3-170.

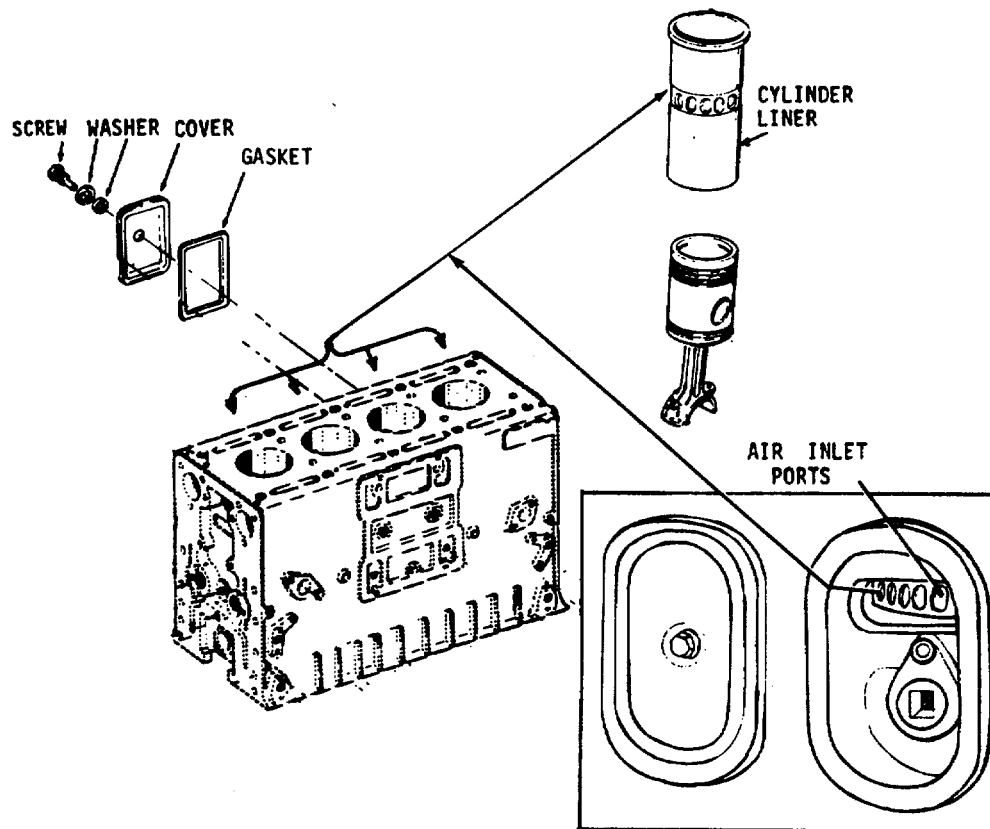

Table 3-60. Anchor Winch Engine - Hard Starting
Troubleshooting (Cont).

| MALFUNCTION | TEST OR INSPECTION | CORRECTIVE ACTION |
|--|--------------------|---|
| 4. Low compression (Cont). | Step 3. | Check for cylinder head gasket leaking. Refer to paragraph 3-163. |
| | Step 4. | Check for improper valve clearance adjustment. Adjust the exhaust valve clearance. Refer to paragraph 3-164. |
| | Step 5. | Check for blower not functioning. Inspect the blower drive shaft and drive coupling. Refer to Direct Support Maintenance. |
| 5. Inoperative starting aid at low ambient temp. | | Check for improper operation of fluid starting aid. Operate the starting aid. Refer to paragraph 2-47. |

Table 3-61. Anchor Winch Engine Abnormal Engine
Operation Troubleshooting.

| MALFUNCTION | TEST OR INSPECTION | CORRECTIVE ACTION |
|-------------|--------------------|-------------------|
|-------------|--------------------|-------------------|

1. Uneven running or frequent stalling.

Step 1. Inspect for low coolant temperature.

Check the engine coolant temperature gage 8nd, if the temperature does not reach 160 to 185 °F, (71 to 85 °C), while the engine is operating, consult the Abnormal Engine Coolant Temperature table 3-66.

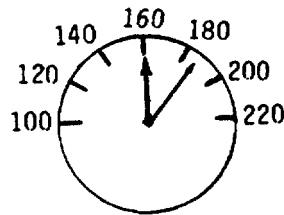

Step 2. Check for insufficient Fuel.

Check engine fuel spill back and if the return is less than 0.8 gallons per minute with engine at 1200 RPM. Consult the No Fuel or insufficient Fuel table 3-59.

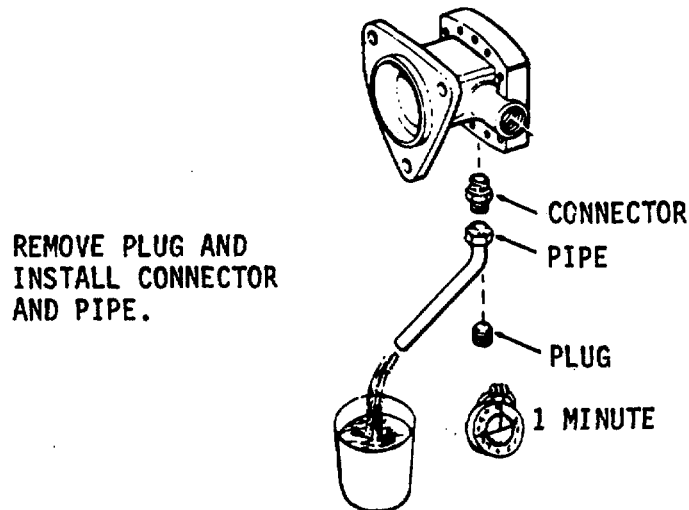

Table 3-61. Anchor Winch Engine Abnormal Engine
Operation Troubleshooting (Cont).

| MALFUNCTION | TEST OR INSPECTION | CORRECTIVE ACTION |
|-------------|--------------------|-------------------|
|-------------|--------------------|-------------------|

1. Uneven running or frequent stalling (Cont).

Step 3. a. Check for faulty injector timing and the position of the injector racks.

Refer to paragraph 3-161.

b. Erratic engine operation may also be caused by leaking injector spray tips. Replace the faulty injectors. Refer to paragraph 3-147.

Step 4. Check for low compression pressures within the cylinders.

Consult the Hard Starting table 3-60 if compression pressures are low.

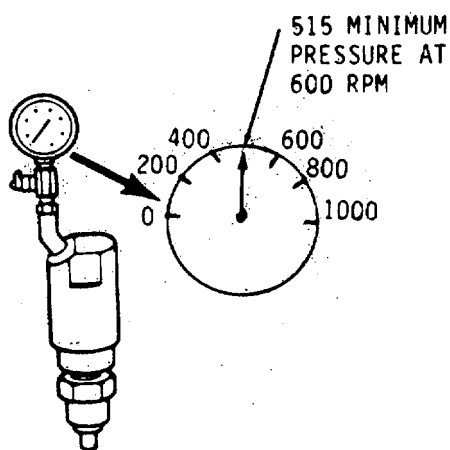

Step 5. Check for governor instability (hunting).

Erratic engine operation may be caused by governor-to-injector operating linkage bind or by misadjusted engine. Refer to paragraph 3-140.

Table 3-61. Anchor Winch Engine Abnormal Engine
Operation Troubleshooting (Cont).

| MALFUNCTION | TEST OR INSPECTION | CORRECTIVE ACTION |
|-------------|--------------------|-------------------|
|-------------|--------------------|-------------------|

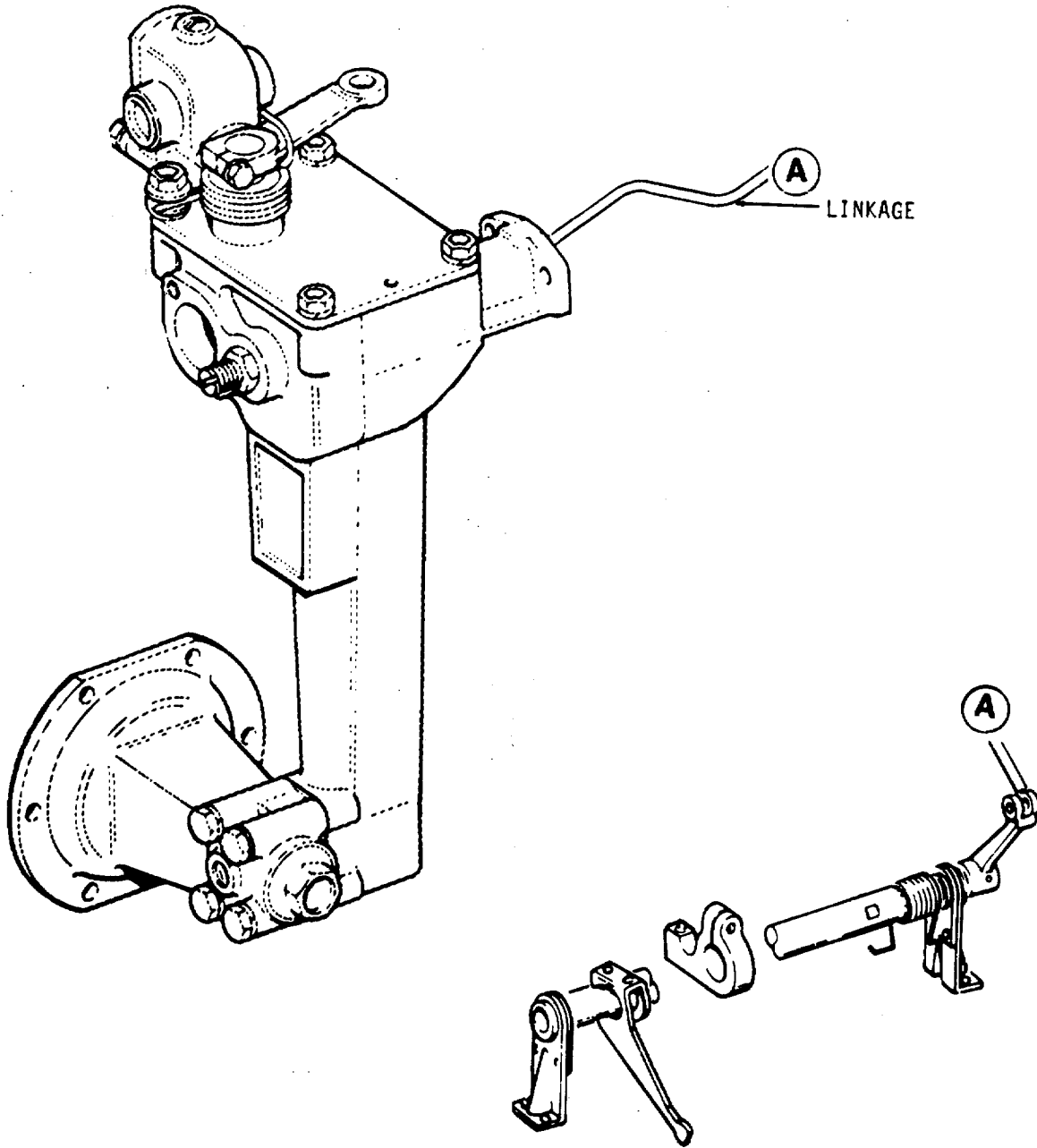

Table 3-61. Anchor Winch Engine Abnormal Engine Operation
 Troubleshooting (Cont).

| MALFUNCTION | TEST OR INSPECTION | CORRECTIVE ACTION |
|-------------|--------------------|-------------------|
|-------------|--------------------|-------------------|

2. Lack of power.

Step 1. Check for improper engine adjustment and gear train timing.

Perform adjustments in paragraph 3-142, 3-154, 3-161, and 3-164, if performance is not satisfactory.

Check the engine gear train timing. An improperly timed gear train will result in a loss of power due to the valves and injectors being actuated at the wrong time in the engine's operating cycle. Refer to paragraph 3-164.

Step 2. Check for insufficient fuel.

Perform a Fuel Flow Test and, if less than 0.8 gallons per minute with engine at 1200 RPM is returning to the fuel tank, consult the No Fuel or Insufficient Fuel table 3-62.

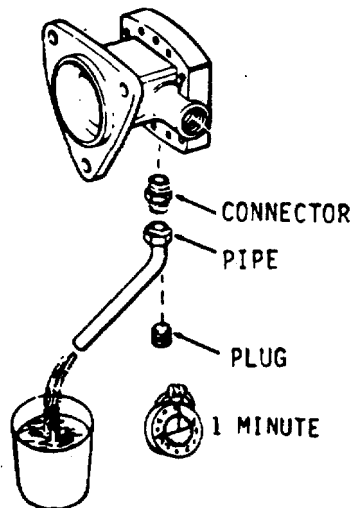

REMOVE PLUG AND INSTALL CONNECTOR AND PIPE.

Table 3-61. Anchor Winch Engine Abnormal Engine Operation
 Troubleshooting (Cont).

| MALFUNCTION | TEST OR INSPECTION | CORRECTIVE ACTION |
|-------------|--------------------|-------------------|
|-------------|--------------------|-------------------|

2. Lack of power (Cont).

Step 3. Check for insufficient air.

a. Check for damaged or dirty air cleaners.

Clean, repair or replace damaged parts.

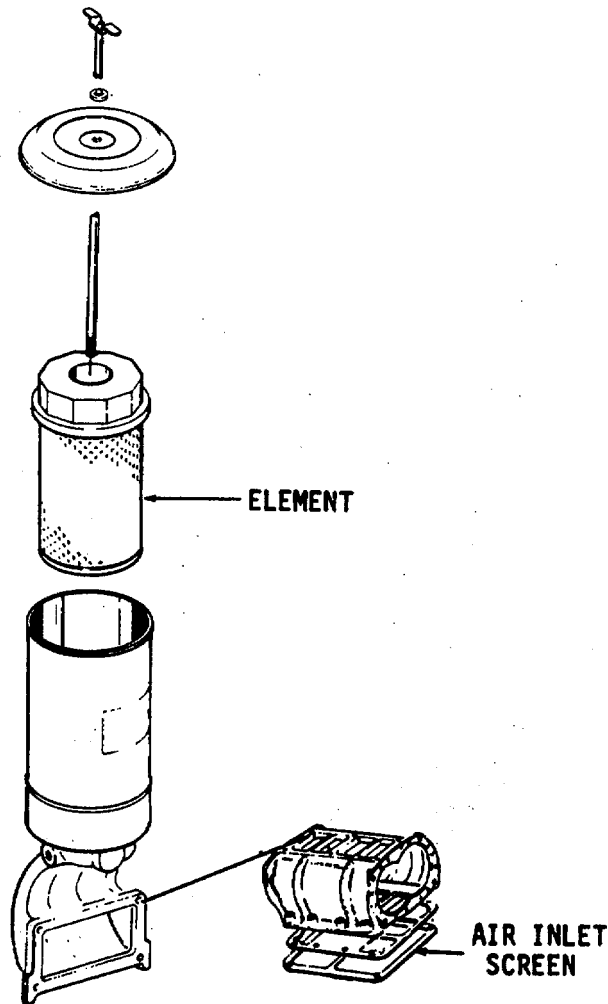

Table 3-61. Anchor Winch Engine Abnormal Engine Operation
 Troubleshooting (Cont).

| MALFUNCTION | TEST OR INSPECTION | CORRECTIVE ACTION |
|-------------|--------------------|-------------------|
|-------------|--------------------|-------------------|

2. Lack of power (Cont).

Step 3. b. Remove the air box covers and inspect the cylinder liner ports.

Clean the ports if they are over 50% plugged.

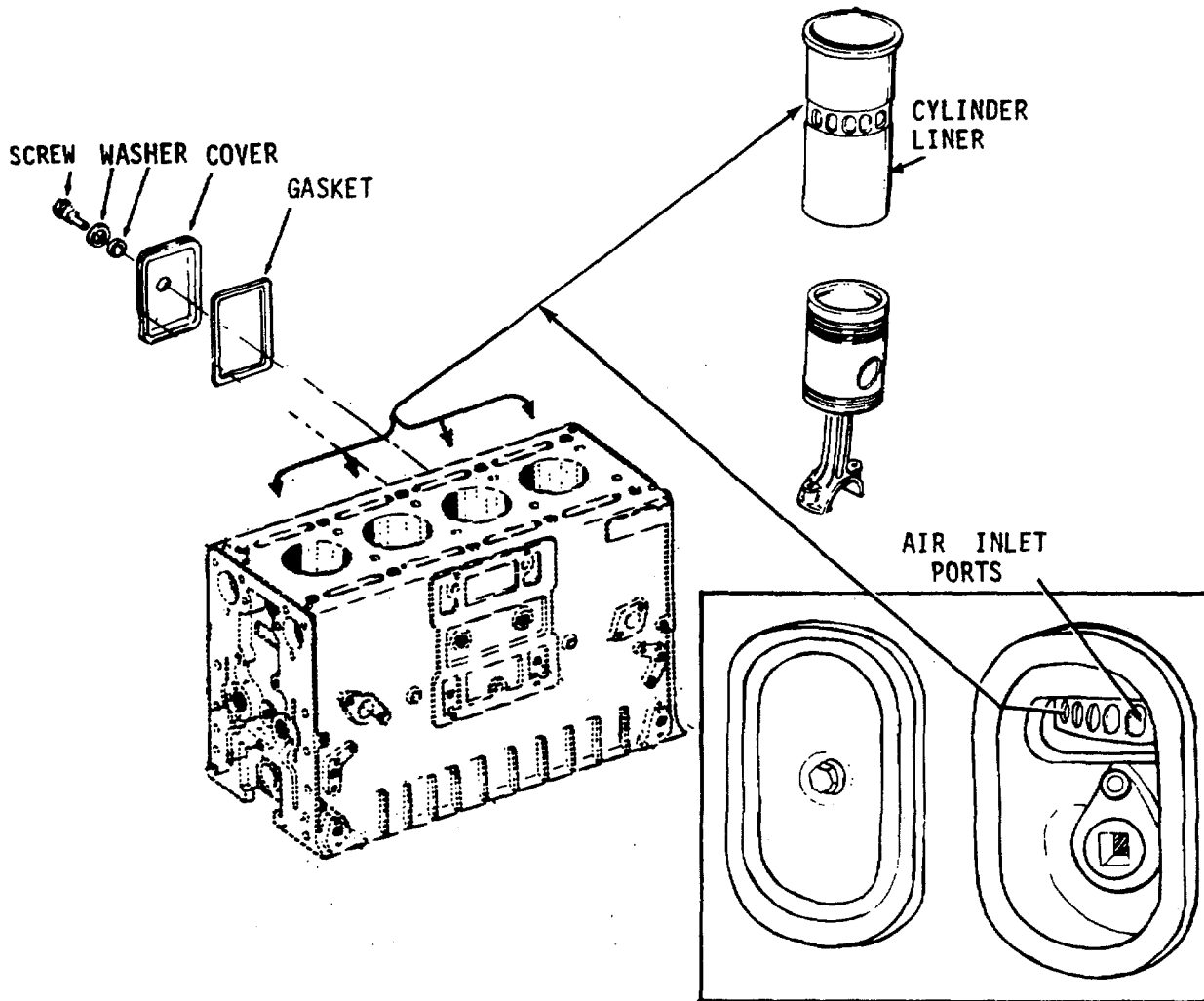

Table 3-61. Anchor Winch Engine Abnormal Engine Operation
 Troubleshooting (Cont).

| MALFUNCTION | TEST OR INSPECTION | CORRECTIVE ACTION |
|-------------|--------------------|-------------------|
|-------------|--------------------|-------------------|

2. Lack of power (Cont).

Step 3. c. Check for blower air intake obstruction or high exhaust back pressure.

Clean, repair or replace faulty parts.

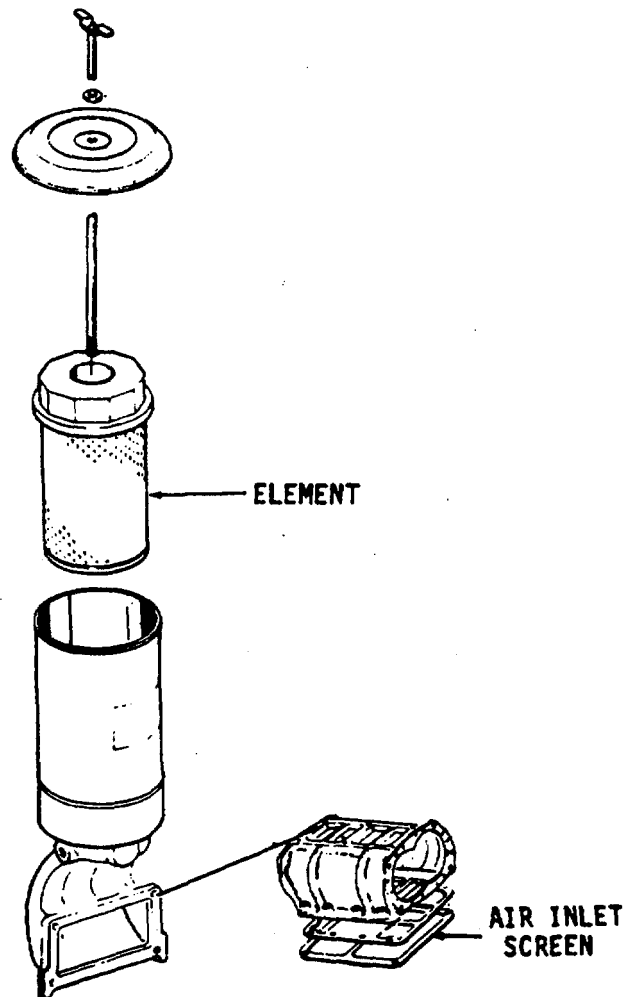

Table 3-61. Anchor Winch Engine Abnormal Engine Operation
 Troubleshooting (Cont).

| MALFUNCTION | TEST OR INSPECTION | CORRECTIVE ACTION |
|-------------|--------------------|-------------------|
|-------------|--------------------|-------------------|

2. Lack of power (Cont).

Step 3. d. Check the compression pressures.

Refer to the Hard Starting table 3-60.

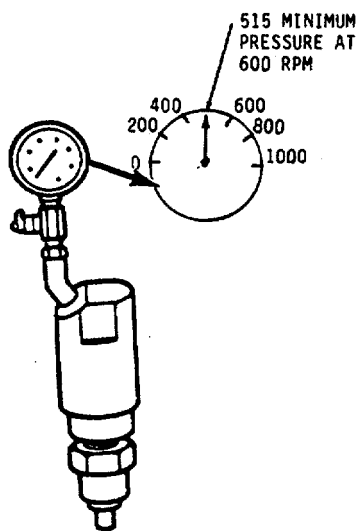

Step 4. Check for incorrect operation of the engine which may result in excessive loads on the engine.

Operate the engine according to the approved procedures.

Step 5. Check for high return fuel temperature.

Refer to table 3-62.

Step 6. Check for high ambient air temperature.

Check the ambient air temperature. A power decrease of .15 to .50-horsepower per cylinder, depending upon injector size, for each 18 F (5.5 C) temperature rise above 900F (32 C) will occur. Operate ventilation fans provide a cooler source of air.

Table 3-61. Anchor Winch Engine Abnormal Engine Operation
 Troubleshooting (Cont).

| MALFUNCTION | TEST OR INSPECTION | CORRECTIVE ACTION |
|-------------|--------------------|-------------------|
|-------------|--------------------|-------------------|

3. Detonation.

Step 1. Check for oil picked up by air stream.

- a. Clean the air box and drain tubes to prevent accumulations that may be picked up by the air stream and enter the engine's cylinders.

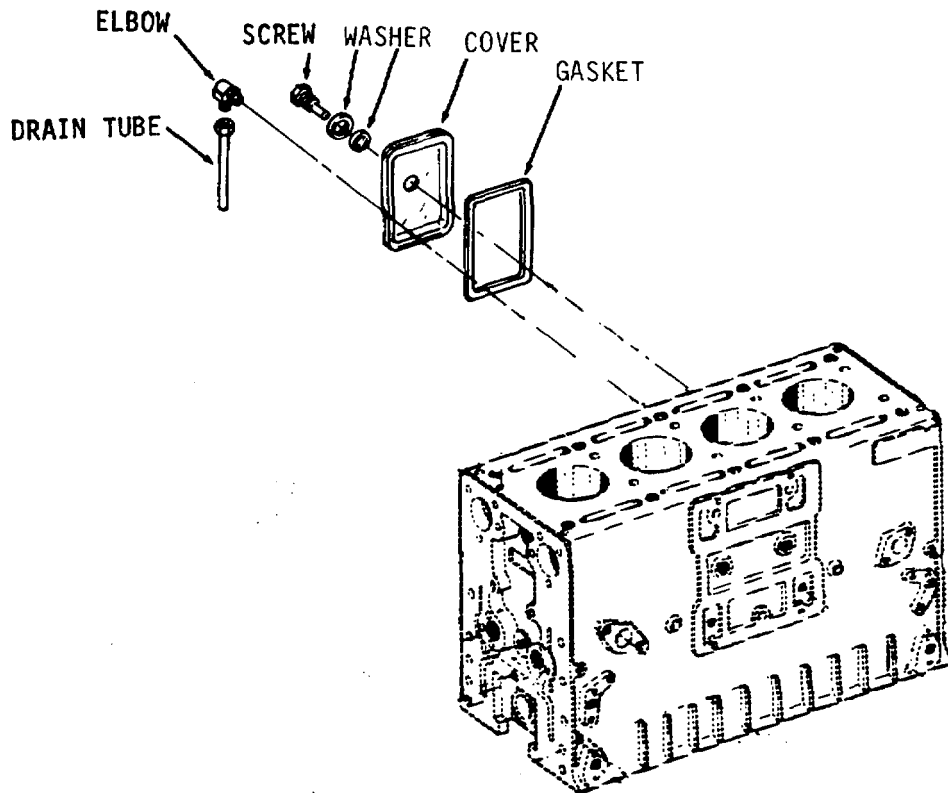
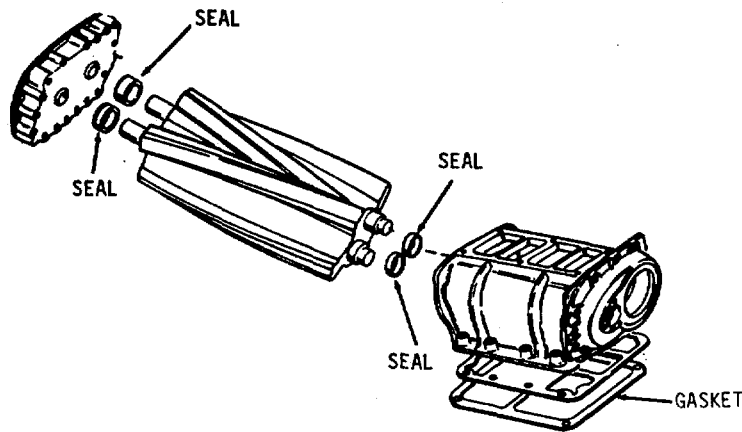

Table 3-61. Anchor Winch Engine Abnormal Engine
Operation Troubleshooting (Cont).

| MALFUNCTION | TEST OR INSPECTION | CORRECTIVE ACTION |
|-------------|--------------------|-------------------|
|-------------|--------------------|-------------------|

3. Detonation (Cont).

b. Inspect the blower oil seals by removing the air inlet housing and watching through the blower inlet for oil radiating away from the blower rotor shaft oil seals while the engine is running. If oil is passing through the seals, Refer to Direct Support Maintenance.



c. Check for a defective blower-to-block gasket.

Replace the gasket, if necessary.

Step 2. Check for low coolant temperature.

Refer to MALFUNCTION 1.

Step 3. Check for faulty injectors.

a. Check injector timing and the position of each injector rack. Refer to paragraph 3-147 and 3-161.

b. The erratic operation may be caused by an injector check valve leaking spray tip holes enlarged or a broken spray tip. Replace faulty injectors. Refer to paragraph 3-147.

Table 3-62. Anchor Winch Engine No Fuel or Insufficient Fuel Troubleshooting.
Refer to figure 3-1 for fuel system piping.

| MALFUNCTION | TEST OR INSPECTION | CORRECTIVE ACTION |
|-------------|--------------------|-------------------|
|-------------|--------------------|-------------------|

1. Air leaks.

Step 1. Check for low fuel supply.

The fuel tank should be filled above the level of the fuel suction tube.

Step 2. Check for loose connections or cracked lines between fuel pump and tank or suction line in tank.

Perform a Fuel Flow Test and, if air is present, tighten loose connections and replace cracked lines. Refer to paragraph 3-146.

NOTE

Fuel flow should be 0.8 gallons per minute with engine at 1200 RPM.

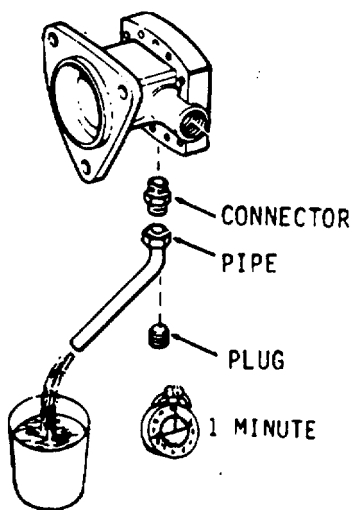

Remove plug and install connector and pipe.

Table 3-62. Anchor Winch Engine No Fuel or
 Insufficient Fuel Troubleshooting (Cont).
 Refer to figure 3-1 for fuel system piping.

| MALFUNCTION | | TEST OR INSPECTION | CORRECTIVE ACTION |
|-------------|-------------------|--------------------|---|
| 1. | Air leaks (Cont). | Step 3. | Check for damaged fuel oil strainer gasket. Perform a Fuel Flow Test and, if air is present, replace the fuel strainer gasket when changing the strainer element. Refer to paragraph 3-147. |
| | | Step 4. | Check for faulty injector tip assembly. Perform a Fuel Flow Test and, if air is present with all fuel lines and connections assembled correctly, check for and replace faulty injectors. Refer to paragraph 3-148. |
| | | Step 1. | Check the fuel strainer or lines for restrictions. Perform a Fuel Flow Test and replace the fuel strainer and filter elements and the fuel lines, if necessary. Refer to paragraph 3-147. |
| | | Step 2. | Check for temperature less than 100F (5.50C) above pour point of fuel. Use the Proper Grade of Fuel |
| DIESEL FUEL | | | |

| TYPE | NATIONAL STOCK NUMBER |
|----------------|-----------------------|
| ARTIC (DF-A) | 9140-00-286-5283 |
| WINTER (DF-W) | 9140-00-286-5286 |
| REGULAR (DF-2) | 9140-00-286-5294 |

Table 3-62. Anchor Winch Engine No Fuel or Insufficient
Fuel Troubleshooting (Cont).

MALFUNCTION

TEST OR INSPECTION

CORRECTIVE ACTION

3. Faulty fuel pump.

Step 1. Check for relief valve not seating.

Perform a Fuel Oil Test and, if inadequate, clean and inspect the valve seat assembly. Refer to paragraph 3-146.

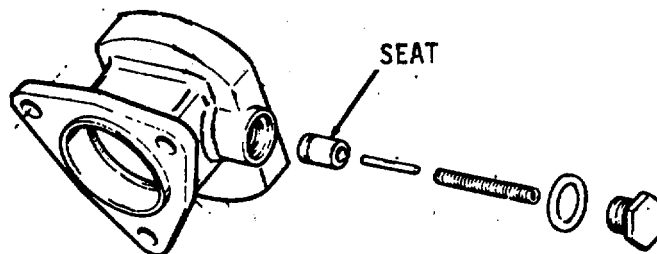

Step 2. Inspect for worn gears or pump body.

Refer to Direct Support Maintenance.

Step 3. Check for fuel pump not rotating.

Check the condition of the fuel pump drive and blower drive and replace defective parts. Refer to paragraphs 3-143, 3-145, and 3-146.

Table 3-62. Anchor Winch Engine No Fuel or Insufficient
 Fuel Troubleshooting (Cont).

| MALFUNCTION | TEST OR INSPECTION | CORRECTIVE ACTION |
|-------------|--------------------|-------------------|
|-------------|--------------------|-------------------|

4. Faulty installation (Cont).

Step 1. Check for restricted fitting missing from return line.

Install a restricted fitting elbow in the return line.

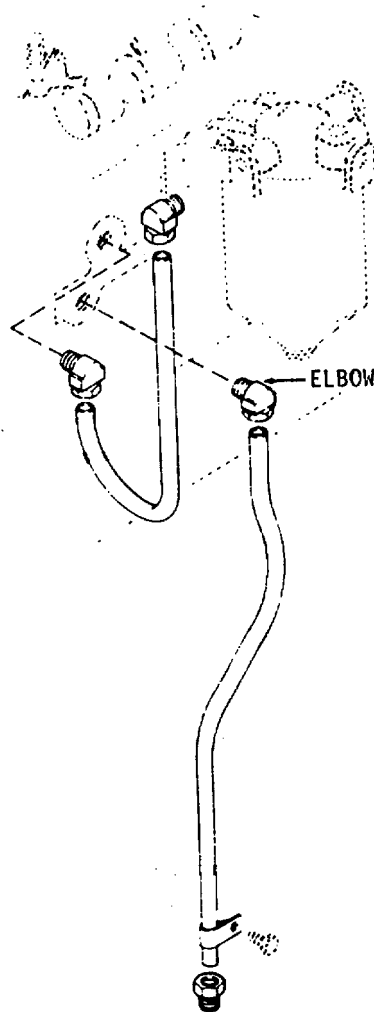

Table 3-62. Anchor Winch Engine No Fuel or Insufficient Fuel Troubleshooting (Cont).

| MALFUNCTION | TEST OR INSPECTION | CORRECTIVE ACTION |
|-------------|--------------------|-------------------|
|-------------|--------------------|-------------------|

4. Faulty installation (Cont).

Step 2. Check for inoperative fuel return line check lift valve.

Make sure that the check valve is installed in the line correctly; the arrow should be on top of the valve assembly or pointing upward. If the valve is inoperative, replace it with a new valve assembly. Refer to paragraph 3-147.

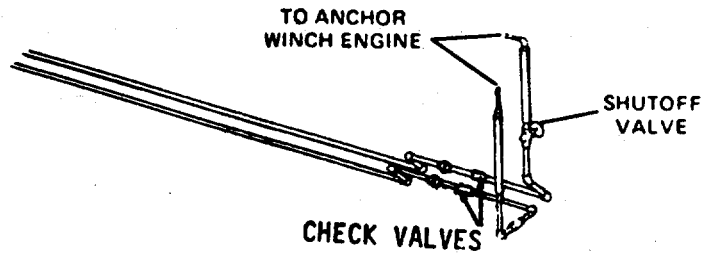

Step 3. Check for high fuel return temperature.

Check the engine fuel spill-back temperature. The return fuel temperature must be less than 150°F (65.5°C) or a loss in horsepower will occur. This condition may be corrected by installing larger fuel lines or using the fuel oil heat exchanger.

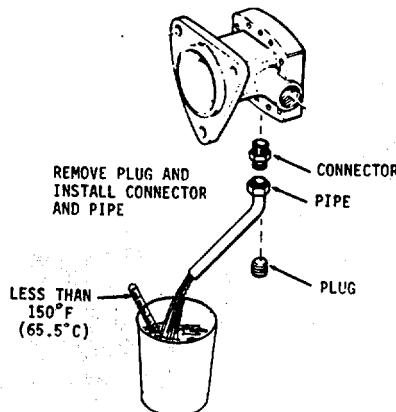

Table 3-63. Anchor Winch Engine High Lubricating
Oil Consumption Troubleshooting.

| MALFUNCTION | TEST OR INSPECTION | CORRECTIVE ACTION |
|-------------|--------------------|-------------------|
|-------------|--------------------|-------------------|

1. External leaks.

Step 1. Check for oil lines or connections for leaking.

Tighten connections or replace defective parts. Refer to paragraph 3-169.

Step 2. Check for gasket or oil seal leaks.

Replace defective gaskets or oil seals. Refer to paragraph 3-169.

Step 3. Check for high crankcase pressure. Refer to the Excessive Crankcase Pressure table 3-64.

Step 4. Check for excessive oil in air box.

Refer to the Abnormal Engine Operation table 3-60.

2. Internal leaks.

Step 1. Check blower oil seal for leaking.

Remove the air inlet housing and inspect the blower end plates while the engine is operating. If oil is seen on the end plate radiating away from the oil seal, refer to Direct Support Maintenance.

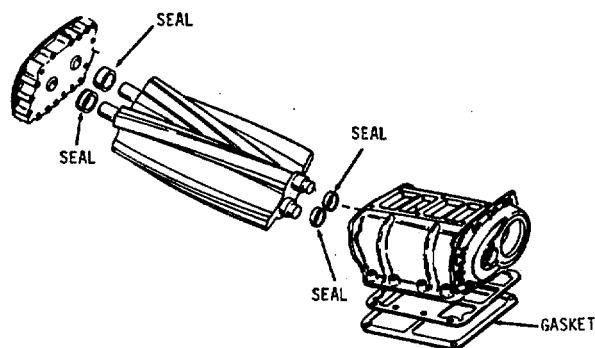

Table 3-63. Anchor Winch Engine High Lubricating
Oil Consumption Troubleshooting (Cont).

| MALFUNCTION | TEST OR INSPECTION | CORRECTIVE ACTION |
|-----------------------------|--------------------|---|
| 2. Internal leaks (Cont). | Step 2. | <p>Check oil cooler core for leaking.</p> <p>Inspect the engine coolant for lubricating oil contamination; if contaminated, replace the oil cooler core. Then use a good grade of cooling system cleaner to remove the oil from the cooling system. Refer to paragraph 3-169.</p> |
| 3. Oil control at cylinder. | Step 1. | <p>Check for oil control rings that are worn, broken or improperly installed.</p> <p>Replace the oil control rings. Refer to paragraph 3-170.</p> |
| | Step 2. | <p>Check piston pin retainer for looseness.</p> <p>Replace the piston pin retainer and defective parts. Refer to paragraph 3-170.</p> |
| | Step 3. | <p>Check for scored liners, pistons or oil rings.</p> <p>Remove and replace the defective parts.</p> |
| | Step 4. | <p>Check piston and rod alignment.</p> <p>Check the crankshaft thrust washers for wear. Replace worn and defective parts. Refer to paragraph 3-170.</p> |
| | Step 5. | <p>Check for excessive oil in crankcase.</p> <p>Fill the crankcase to the proper level only.</p> |

Table 3-64. Anchor Winch Engine Excessive Crankcase
Pressure Troubleshooting.

| MALFUNCTION | TEST OR INSPECTION | CORRECTIVE ACTION |
|-------------|--------------------|-------------------|
|-------------|--------------------|-------------------|

1. Cylinder blow-by.

Step 1. Check cylinder head gasket for leaking.

Check the compression pressure and, if only one cylinder has low compression, remove the cylinder head and replace the head gaskets. Refer to paragraph 3-163.

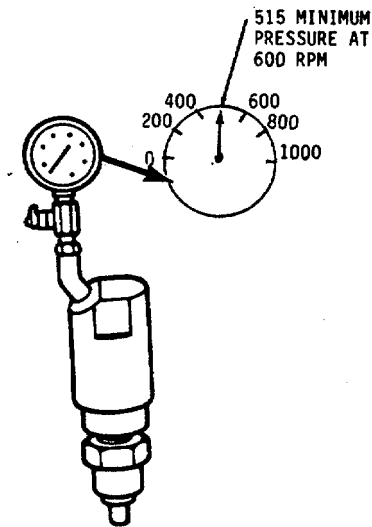

Step 2. Check for piston or liner damaged.

Inspect the piston and liner and replace damaged parts. Refer to paragraph 3-163.

Step 3. Inspect for piston rings that are worn or broken.

Install new piston rings. Refer to paragraph 3-163.

Table 3-64. Anchor Winch Engine Excessive Crankcase
Pressure Troubleshooting (Cont).

MALFUNCTION

TEST OR INSPECTION

CORRECTIVE ACTION

2. Breather restriction.

Step 1. Check for obstruction or damage to breather.

Clean and repair or replace the breather assembly. Refer to paragraph 3-142.

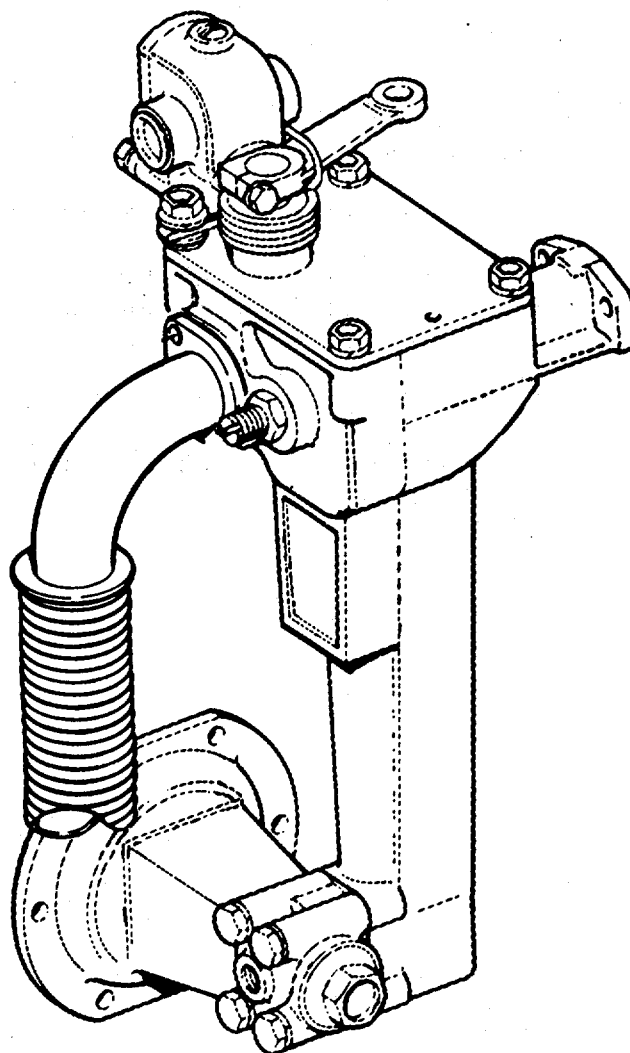

3-197

Table 3-64. Anchor Winch Engine Excessive Crankcase
Pressure Troubleshooting (Cont).

| MALFUNCTION | TEST OR INSPECTION | CORRECTIVE ACTION |
|-------------------------------------|--|--|
| 3. Air from blower or air box. | Step 1. Check for damaged blower-to-block gasket. | Replace the blower-to-block gasket. Refer to paragraph 3-144. |
| | Step 2. Check cylinder block end plate gasket for leaking. | Replace the end plate gasket. Refer to paragraph 3-173. |
| 4. Excessive exhaust back pressure. | Step 1. Check for excessive muffler resistance. | Check the exhaust back pressure and repair or replace the muffler if an obstruction is found. Refer to Direct Support Maintenance. |
| | Step 2. Check for faulty exhaust piping. | Check the exhaust back pressure. Refer to Direct Support Maintenance. |

Table 3-65. Anchor Winch Engine - Low Oil Pressure - Troubleshooting.

MALFUNCTION**TEST OR INSPECTION****CORRECTIVE ACTION**

NOTE

Make checks with minimum water outlet temperature of 160°F (71°C).

1. Lubricating oil.

Step 1. Check for suction loss.

Check oil and bring to proper level on dipstick.

Step 2. Check lubricating oil viscosity.

Check for recommended grade and viscosity of oil.

Table 3-65. Anchor Winch Engine - Low Oil Pressure - Troubleshooting.
(Cont).

MALFUNCTION

TEST OR INSPECTION

CORRECTIVE ACTION

LUBRICATING OIL GRADES

DESCRIPTION

SPECIFICATION

| | |
|----------------|-------------|
| OES (Sub Zero) | MIL-L-10295 |
| OE/HDO - 10 | MIL-L-2104 |
| OE/HDO - 20 | MIL-L-2104 |
| OE/HDO - 30 | MIL-L-2104 |

Check for fuel leaks at the injector nut seal ring and fuel pipe connections. Leaks at these points will cause lubricating oil dilution. Refer to paragraph 3-147.

2. Poor circulation.

Step 1. Check cooler for clogging.

A plugged oil cooler is indicated by excessively high lubricating oil temperature. Remove and clean the oil cooler core. Refer to paragraph 3-149.

Step 2. Check for cooler by-pass valve not functioning properly.

Remove the by-pass valve and clean the valve and valve seat and inspect the valve spring. Replace defective parts. Refer to paragraph 3-167.

Table 3-65. Anchor Winch Engine Low Oil
Pressure Troubleshooting (Cont).

| MALFUNCTION | TEST OR INSPECTION | CORRECTIVE ACTION |
|-------------|--------------------------|--|
| 2. | Poor circulation (Cont). | |
| | Step 3. | Check for pressure regulator valve that is not functioning properly. Remove the pressure regulator valve and clean the valve and valve seat and inspect the valve spring. Replace defective parts. Refer to paragraph 3-167. |
| | Step 4. | Check for excessive wear on crankshaft bearings. a. Change the bearings. Refer to paragraph 3-171. b. Refer to Lubrication Oil Grades for the proper grade and viscosity of oil. c. Change the oil filters. Refer to paragraph 3-148. |
| | Step 5. | Check for gallery, crankshaft or camshaft plugs missing. Replace missing plugs. Refer to paragraph 3-166. |
| 3. | Pressure gage. | |
| | Step 1. | Check for faulty gage. Check the oil pressure with a reliable gage and replace the gage if found faulty. Refer to paragraph 3-174. |
| | Step 2. | Check for gage line obstruction. Remove and clean the gage line; replace it, if necessary. Refer to paragraph 3-174. |
| | Step 3. | Check gage orifice for plugging. Remove and clean the gage orifice. Refer to paragraph 3-174. |

Table 3-65. Anchor Winch Engine Low Oil
Pressure Troubleshooting (Cont).

| MALFUNCTION | TEST OR INSPECTION | CORRECTIVE ACTION |
|--------------|--------------------|---|
| 4. Oil pump. | Step 1. | <p>Check intake screen for partial clogging.</p> <p>a. Remove and clean the oil pan and oil intake screen. Refer to paragraphs 3-162, 3-167, and 3-169.</p> <p>b. Consult the Lubricating Oil Grades for the proper grade and viscosity of oil. Change the oil filters. Refer to paragraph 3-148.</p> |
| | Step 2. | <p>Check for faulty relief valve.</p> <p>Remove and inspect the valve, valve bore and spring. Replace faulty parts. Refer to paragraph 3-167.</p> |
| | Step 3. | <p>Check for air leak in pump suction.</p> <p>Disassemble the piping and install new gaskets. Refer to paragraph 3-168.</p> |
| | Step 4. | <p>Check pump for wear or damage.</p> <p>Remove the pump. Clean and replace defective parts. Refer to paragraph 3-168.</p> |
| | Step 5. | <p>Check for flange leak (pressure side).</p> <p>Remove the flange and replace the gasket. Refer to paragraph 3-168.</p> |

Table 3-66. Anchor Winch Engine Abnormal Engine
Coolant Operating Temperature Troubleshooting.

| MALFUNCTION | TEST OR INSPECTION | CORRECTIVE ACTION |
|-------------|---------------------------|--|
| 1. | Temperature above normal. | <p data-bbox="289 533 846 558">Step 1. Check for insufficient heat transfer.</p> <p data-bbox="477 596 1474 653">Clean the cooling system with a good cooling system cleaner and thoroughly flush to remove scale deposits.</p> <p data-bbox="289 688 740 714">Step 2. Check for poor circulation.</p> <p data-bbox="428 749 1344 774">a. Check the coolant level and fill to the filler neck if the coolant level is low.</p> <p data-bbox="428 812 1507 869">b. Inspect for collapsed or disintegrated hoses. Replace faulty hoses. Refer to paragraph 3-151.</p> <p data-bbox="428 907 1484 963">c. Thermostat may be inoperative. Remove, inspect and test the thermostat; replace if found faulty. Refer to paragraph 3-153.</p> <p data-bbox="428 1001 1458 1026">d. Check the water pump for a loose or damaged impeller. Refer to paragraph 3-150.</p> <p data-bbox="428 1064 1528 1146">e. Check the flow of coolant through the keel cooler. A clogged keel cooler will cause an inadequate supply of coolant on the suction side of the pump. Clean the keel cooler. Refer to paragraph 3-151 and Direct Support Maintenance.</p> <p data-bbox="428 1184 1479 1266">f. The cylinder head must be removed and inspected for cracks and the head gaskets replaced if combustion gases are entering the cooling system. Refer to paragraph 3-163.</p> <p data-bbox="428 1304 1484 1360">g. Check for an air leak on the suction side of the water pump. Replace defective parts. Refer to paragraph 3-150.</p> |

Table 3-66. Anchor Winch Engine Abnormal Engine Coolant
Operating Temperature Troubleshooting (Cont).

| MALFUNCTION | TEST OR INSPECTION | CORRECTIVE ACTION |
|------------------------------|---|---|
| 2. Temperature below normal. | Step 1. Check for improper circulation. | The thermostat may not be closing. Remove, inspect and test the thermostat. Install a new thermostat, if necessary. Refer to paragraph 3-153. |
| | Step 2. Check for excessive leakage at thermostat seal. | Excessive leakage of coolant past the thermostat seal(s) is a cause of continued low coolant operating temperature. When this occurs, replace the thermostat seal(s). Refer to paragraph 3-153. |

Table 3-67. Anchor Winch Engine Low or High Exhaust Valve
Opening Pressure Troubleshooting.

| MALFUNCTION | TEST OR INSPECTION | CORRECTIVE ACTION |
|-------------|-------------------------------------|--|
| 1. | Low exhaust valve opening pressure. | |
| | Step 1. | Check for worn or eroded valve seat. Replace worn or eroded valve seat. Refer to paragraph 3-163. |
| | Step 2. | Check valve seat for chips at point of contact with valve. Replace valve seat. Refer to paragraph 3-163. |
| | Step 3. | Check for cracked valve seat. Replace the valve seat. Refer to paragraph 3-163. |
| | Step 4. | Check for worn valve or valve locks. Replace the valve or valve locks. Refer to paragraph 3-164. |
| | Step 5. | Check for worn or broken valve spring. Replace the spring. Check the valve cage and valve stop for wear; replace them if necessary. Refer to paragraph 3-164. |
| | Step 6. | Check for dirt or foreign material in injector. Replace the injector. Refer to paragraph 3-147. |
| | Step 7. | Check for worn valve spring stop seat. Replace the valve spring stop seat. Refer to paragraph 3-163. |
| 2. | High valve opening pressure. | |
| | Step 1. | Check for carbon or foreign material in injector spray tip. Replace injector. Refer to paragraph 3-147. |

Table 3-68. Anchor Winch Engine Low or No Accumulator

Pressure Troubleshooting

MALFUNCTION

TEST OR INSPECTION

CORRECTIVE ACTION

1. Engine driven pump fails to raise pressure.

Step 1. Check for air in system.

To purge the engine driven pump of air:

- a. Operate the engine at maximum no-load engine speed.
- b. Break the hose connection (1) at the pressure side of the engine-driven pump until a full stream of oil is discharged from the pump.
- c. Connect the hose to the pump and alternately loosen and tighten the swivel fitting (2) on the pressure hose until oil leaking out, when the fitting is loose, appears free of air bubbles.
- d. Tighten the swivel fitting (2) securely and observe the pressure gage. The pressure must rise rapidly to the accumulator precharge pressure (1250 psi at 70 F) then increase slowly to 2900 to 3300 psi in 6 to 10 minutes, depending upon the size of the particular accumulator.
- e. If the accumulator pressure does not rise, make certain that the hand pump relief valve (3) is closed after the pressure is released and repeat the above purging procedure.

Table 3-68. Anchor Winch Engine Low or No Accumulator

Pressure Troubleshooting (Cont).

| MALFUNCTION | TEST OR INSPECTION | CORRECTIVE ACTION |
|-------------|--------------------|-------------------|
|-------------|--------------------|-------------------|

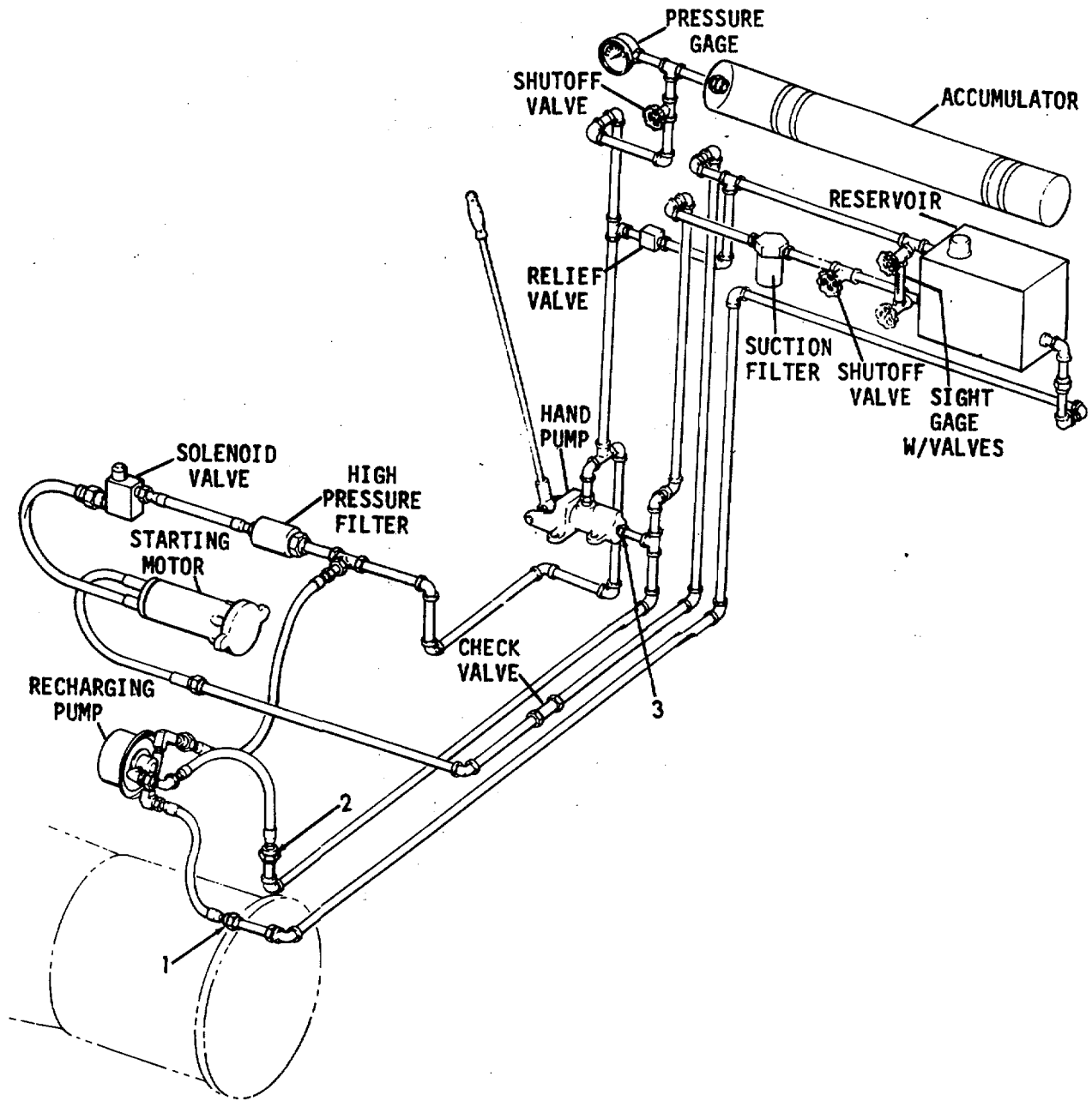

Table 3-68. Anchor Winch Engine Low or No Accumulator
 Pressure Troubleshooting (Cont).

| MALFUNCTION | TEST OR INSPECTION | CORRECTIVE ACTION |
|-------------|--------------------|-------------------|
|-------------|--------------------|-------------------|

1. Engine driven pump fails to raise pressure (Cont).

Step 2. Check for low fluid level.

The fluid level in the reservoir must be sufficient to completely cover the screen at the bottom of the tank after the accumulator is charged and the engine-driven pump is bypassing a full stream of fluid to the reservoir.

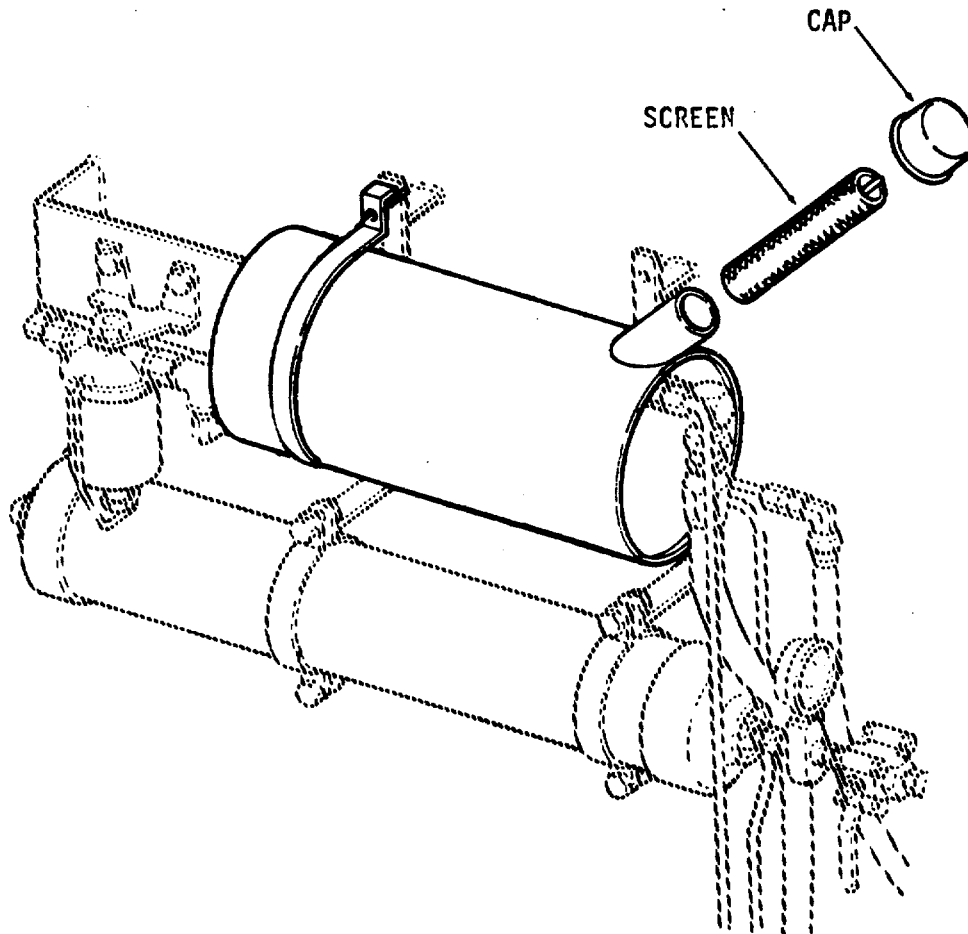

Table 3-68. Anchor Winch Engine - Low or No Accumulator
Pressure - Troubleshooting (Cont).

MALFUNCTION

TEST OR INSPECTION

CORRECTIVE ACTION

1. Engine driven pump fails to raise pressure (Cont).

Step 3. Check for plugged screen or filter.

- a. Remove and clean the reservoir screen and flush out the reservoir tank. Refer to paragraph 3-180.
- b. Clean the filter located in supply hose between the reservoir and engine-driven pump. Refer to paragraph 3-180.

Step 4. Check for check valves that are not functioning properly.

- a. Open relief valve (3) on the rear of the hand pump while the engine is running. This lets the engine-driven pump wash the check valves free of particles.

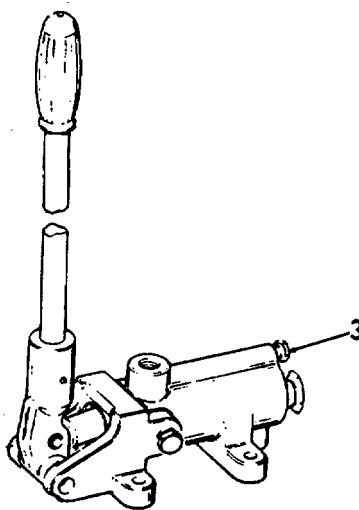

- b. If accumulator can be charged with the hand pump but not with the engine-driven pump, a check valve in the engine pump is defective. Replace the faulty check valve assembly. Refer to paragraph 3-178.

Step 5. Check for defective drive.

Replace the pump drive arm. Refer to paragraph 3-178.

Table 3-69. Anchor Winch Engine - Hydrostarter Cranking
Speed Too Low Troubleshooting.

MALFUNCTION

TEST OR INSPECTION

CORRECTIVE ACTION

1. Cranking speed to low.

Step 1. Check that hydrostarter system fluid is not too heavy.

Check fluid in the system. Use hydraulic fluid MIL-L-17672, Type 2135 TH.

Step 2. Check that engine oil is not too heavy.

Replace the oil with the proper viscosity grade.

LUBRICATING OIL GRADES

| DESCRIPTION | SPECIFICATION |
|----------------|---------------|
| OES (Sub Zero) | MIL-L-10295 |
| OE/HDO - 10 | MIL-L-2104 |
| OE/HDO - 20 | MIL-L-2104 |
| OE/HDO - 30 | MIL-L-2104 |

Step 3. Check for control valve that is not fully opens

Valve body sticking in valve housing. Replace valve cage and valve assembly.

Step 4. Check for restricted inlet line.

Check plumbing from accumulator to hydrostarter to insure hoses are not collapsed and are free of obstructions.

Step 5. Check for excessive internal leakage in hydro-starter.

Examine around hydrostarter for broken thrust bearing plate, scored port plate, frozen piston or broken cylinder spring.

Table 3-70. Anchor Winch Engine - Hydrostarter Loss of Fluid
from Reservoir Troubleshooting.

| MALFUNCTION | TEST OR INSPECTION | CORRECTIVE ACTION |
|----------------------------------|--|---|
| 1. Loss of fluid from reservoir. | Step 1. Check for external leaks. | With pressure in the system, check all hoses and fittings for leaks. Tighten the fittings. Refer to Direct Support Maintenance. |
| | Step 2. Check for leaking hydrostarter shaft seal. | Remove hydrostarter inspection cover and look for signs of hydraulic oil on the Bendix drive, the Hydrostarter shaft and inside the pinion gear housing. Refer to Direct Support Maintenance. |
| | Step 3. Check for leaking engine pump shaft seal. | Refer to Direct Support Maintenance. |
| | Step 4. Check for leaking hand pump seal. | Remove plunger gland and replace inner and outer O-rings. |
| | | Table 3-71. Anchor Winch Engine - Hydrostarter Loss of Fluid Pressure When Engine is Not Running Troubleshooting. |

| MALFUNCTION | TEST OR INSPECTION | CORRECTIVE ACTION |
|---|---|---|
| 1. Loss of fluid pressure when engine is not running. | Step 1. Check for ambient temperature decrease. | A drop in temperature will decrease the nitrogen pressure. Adjust the pressure as needed for cranking requirements by use of the hand pump. |

Table 3-71. Anchor Winch Engine - Hydrostarter Loss of Fluid
Pressure When Engine is Not Running Troubleshooting (Cont).

| MALFUNCTION | TEST OR INSPECTION | CORRECTIVE ACTION |
|-------------|---|--|
| 1. | Loss of fluid pressure when engine is not running (Cont). | |
| | Step 2. | <p>Check for engine driven pump check valves not holding.</p> <p>Disconnect the return hose and inlet hose from the engine-driven pump. Leakage from the inlet fitting means that both check valves are defective. Leakage at the return fitting means that only the outlet check valve is defective. Replace the defective check valve assembly(s). Refer to paragraph 3-178.</p> |
| | Step 3. | <p>Check hand pump valves for not holding.</p> <p>Disconnect the inlet hose from the hand pump. Leakage from the inlet fitting means that either the relief valve alone or both the inlet and outlet check valves are defective. Stone and clean the ball seats in the pump body and replace the balls and springs if necessary. Refer to paragraph 3-179.</p> |
| | Step 4. | <p>Check for damaged seal ring in starter control valve shown by external leakage.</p> <p>Refer to Direct Support Maintenance.</p> |
| | Step 5. | <p>Check for external leakage in system.</p> <p>Examine all hoses and fittings for leaks. Tighten. Refer to Direct Support Maintenance.</p> |
| | Step 6. | <p>Check for loss of accumulator precharge (nitrogen).</p> <p>See table 3-74.</p> |

Table 3-72. Anchor Winch Engine - Hydrostarter Hand Pump

Fails to Discharge Fluid Troubleshooting.

MALFUNCTION

TEST OR INSPECTION

CORRECTIVE ACTION

1. Hand pump fails to discharge fluid.

Step 1. Check for open manual relief valve.

Close the relief valve.

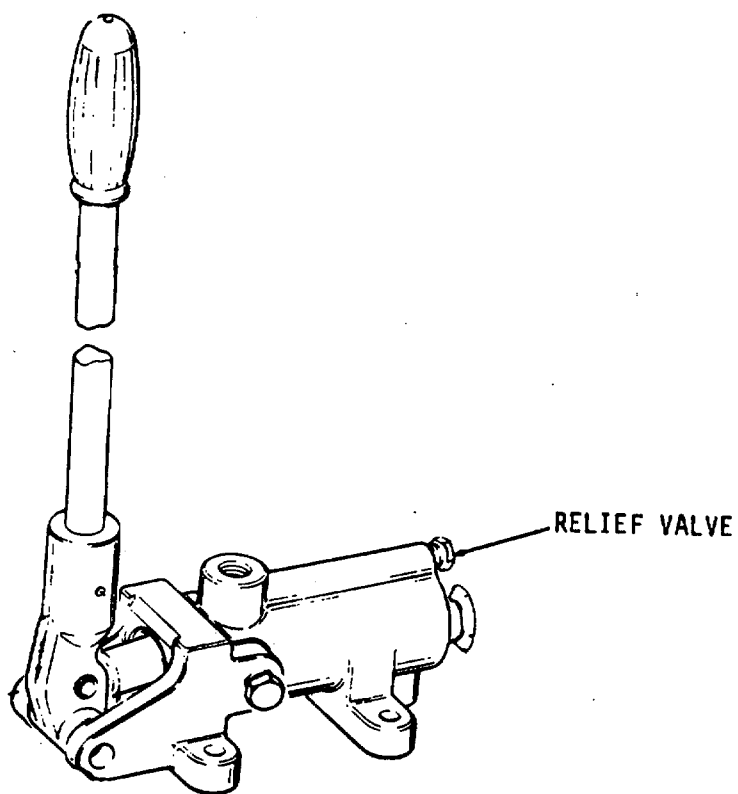

Table 3-72. Anchor Winch Engine - Hydrostarter Hand Pump

Fails to Discharge Fluid Troubleshooting (Cont).

| MALFUNCTION | TEST OR INSPECTION | CORRECTIVE ACTION |
|-------------|--|--|
| 1. | Hand pump fails to discharge fluid (Cont). | |
| | Step 2. | <p data-bbox="428 533 805 558">Check for leaking check valves.</p> <p data-bbox="477 596 1529 747">Hand pump handle will not stay in neutral position but will move to one end of the stroke. If caused by dirt, open the relief valve and operate the hand pump slowly for a few minutes to wash the particles out of the check valves. If this is unsuccessful, stone and clean the ball seats in the pump body and replace the balls and springs if necessary. Refer to paragraph 3-179.</p> |
| | Step 3. | <p data-bbox="428 781 850 806">Check for plugged reservoir screen.</p> <p data-bbox="477 844 1529 898">Remove and clean the reservoir screen, flush the reservoir tank and reassemble. Refer to paragraph 3-180.</p> |
| | Step 4. | <p data-bbox="428 932 721 957">Check for low fluid level.</p> <p data-bbox="477 991 737 1024">See table 3-68 step 2.</p> |
| | Step 5. | <p data-bbox="428 1058 708 1083">Check for air in system.</p> <p data-bbox="477 1117 844 1142">To purge the hand pump of air:</p> <ol data-bbox="477 1176 1529 1360" style="list-style-type: none"> <li data-bbox="477 1176 1529 1234">a. Relieve any system pressure, then disconnect the outlet hose from the hand pump. <li data-bbox="477 1268 1386 1293">b. Close the manual relief valve and operate stroking in both directions. <li data-bbox="477 1327 889 1352">c. Reconnect the outlet hose. |
| | Step 6. | <p data-bbox="428 1394 701 1419">Check for dirt in pump.</p> <p data-bbox="477 1453 610 1478">See step 2.</p> |
| | Step 7. | <p data-bbox="428 1520 870 1545">Check for damaged piston seal rings.</p> <p data-bbox="477 1575 1068 1600">Replace the seal rings. Refer to paragraph 3-179.</p> |

Table 3-73. Anchor Winch Engine - Hydrostarter Starter

Turns but Engine Does Not - Troubleshooting.

| MALFUNCTION | TEST OR INSPECTION | CORRECTIVE ACTION |
|-------------|--------------------|-------------------|
|-------------|--------------------|-------------------|

1. Starter turns but engine does not.

Step 1. Check for pinion not engaging in flywheel ring gear.

Replace as per paragraph 3-176. Refer to Direct Support Maintenance.

Step 2. Check for broken bendix drive.

Replace Bendix drive. Operator should disengage hydrostarter as soon as engine starts. Prolonging the period during which clutch overruns will reduce clutch life.

Table 3-74. Anchor Winch Engine - Hydrostarter

Loss of Accumulator Precharge (Nitrogen) - Troubleshooting.

| MALFUNCTION | TEST OR INSPECTION | CORRECTIVE ACTION |
|-------------|--------------------|-------------------|
|-------------|--------------------|-------------------|

1. Loss of accumulator precharge (nitrogen).

Step 1. Check for damaged seal ring on piston.

With some nitrogen precharge but no fluid pressure in the system, bubbles and foaming in the reservoir indicate that the nitrogen is leaking past the seal ring on the accumulator piston. Refer to Direct Support Maintenance.

Table 3-74. Anchor Winch Engine - Hydrostarter

Loss of Accumulator Precharge (Nitrogen) Troubleshooting (Cont).

| MALFUNCTION | TEST OR INSPECTION | CORRECTIVE ACTION |
|-------------|--------------------|-------------------|
|-------------|--------------------|-------------------|

1. Loss of accumulator precharge (nitrogen) (Cont).

Step 2. Check for defective air valve.

Release the pressure in the system by opening the relief valve on the side of the hand pump. Then, loosen the hex lock nut on the nitrogen valve approximately 3/4 turn to release the remaining precharge before attempting to remove the valve from the accumulator. Replace the air valve. Refer to Direct Support Maintenance.

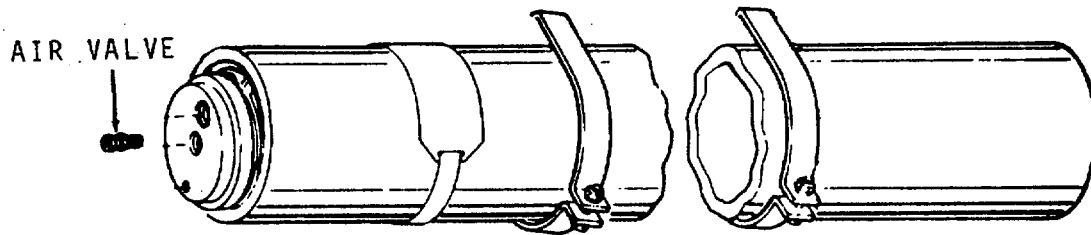

Step 3. Check for damaged seal ring between shell and end cap.

Apply light oil on the threaded end of the accumulator at the end of the cap. Bubbling of the oil indicates a leak past the end cap seal. Refer to Direct Support Maintenance.

Step 4. Check for defective safety fuse.

Replace safety fuse assembly after releasing all nitrogen pressure.

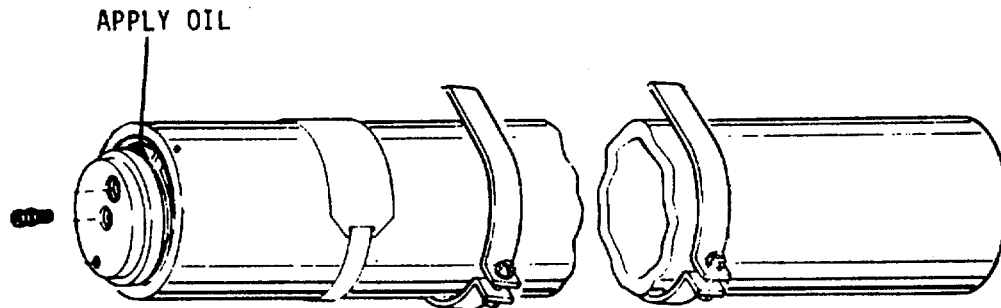

Table 3-75. Anchor Winch Engine - Hydrostarter High Pressure
in System (3500 psi or above) Troubleshooting.

| MALFUNCTION | TEST OR INSPECTION | CORRECTIVE ACTION |
|---|--|--|
| 1. High pressure in system (3500 psi or above). | Step 1. Check for defective gage. | Refer to Direct Support Maintenance. |
| | Step 2. Check for engine driven pump unloading valve not operating properly. | Overhaul the pump. Refer to paragraph 3-178. |

Table 3-76. Anchor Winch Engine - Hydrostarter Fluid Emerges
from the Reservoir Filler Cap When Starter is Used Troubleshooting.

| MALFUNCTION | TEST OR INSPECTION | CORRECTIVE ACTION |
|--|--|---|
| 1. Fluid emerges from the reservoir filler cap when starter is used. | Step 1. Check for filter element in filler cap loaded with dirt. | Rinse the filler cap thoroughly in fuel oil and dry it with compressed air. |
| | Step 2. Check for nitrogen in fluid returned to reservoir. | Overhaul the accumulator. See table 3-74. |
| | Step 3. Check for excess fluid in reservoir. | Check the fluid level when the accumulator is empty. The fluid level should be approximately 2-1/2 inches from the top of the tank. |

Table 3-77. Anchor Winch Engine - Hydrostarter Fluid Emerges
 Around Rubber Boot of Hand Pump - Troubleshooting.

| MALFUNCTION | TEST OR INSPECTION | CORRECTIVE ACTION |
|---|--------------------------------------|--|
| 1. Fluid emerges around rubber boot or hand pump. | Check for damaged piston seal rings. | Replace the seal rings and leather back-up rings on the pump piston. Refer to paragraph 3-179. |

Table 3-78. Hydrostarter - Cranking Cycle Too Short -
 Troubleshooting.

| MALFUNCTION | TEST OR INSPECTION | CORRECTIVE ACTION |
|---------------------------------|--|-------------------|
| 1. Cranking cycle is too short. | <p>Step 1. Check for faulty pressure gage.</p> <p>If gage is reading higher than actual system pressure, oil volume in the accumulator will be less. Replace gage.</p> <p>Step 2. Check for excessive internal leakage in hydro-starter.</p> <p>Refer to table 3-69.</p> <p>Step 3. Check for accumulator precharge too high.</p> <p>With the fuel shut off to prevent engine from starting, crank the engine until all oil is used. If the gage then registers zero pressure, install a gaging assembly on the air valve and drop the precharge to 1250 psi (1695 kPa). Repeat cranking cycle. If gage will still drop to zero at end of cranking cycle, reduce precharge to 1000 psi (1356 kPa).</p> | |

Table 3-78. Hydrostarter - Cranking Cycle Too Short -
Troubleshooting (Cont).

| MALFUNCTION | TEST OR INSPECTION | CORRECTIVE ACTION |
|-------------|--------------------|-------------------|
|-------------|--------------------|-------------------|

1. Cranking cycle is too short (Cont).

Step 4. Check for accumulator precharge too low.

Open the bypass valve on the hand pump to discharge oil from the accumulator. Install a gaging assembly on the accumulator air valve. If precharge is less than 1500 psi (2034 kPa), add nitrogen. Make sure precharge holds by testing for nitrogen leakage. Refer to table 3-74.

Table 3-79. Centralized Hydraulic System - Hydraulic
Power Unit Troubleshooting.

| MALFUNCTION | TEST OR INSPECTION | CORRECTIVE ACTION |
|-------------|--------------------|-------------------|
|-------------|--------------------|-------------------|

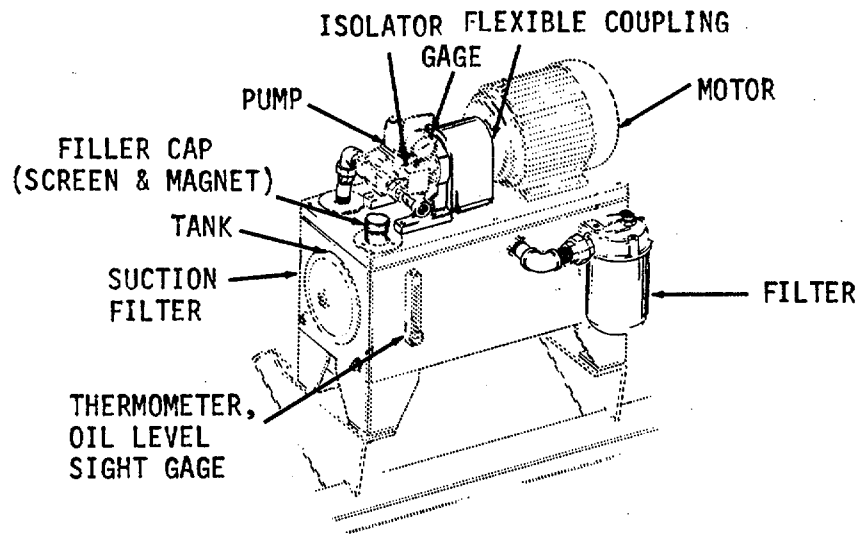

1. Loss of fluid from tank.

Step 1. Check for leaky pipe connections.

Check all lines and connections. Be sure no rubbing or excessive vibration is present. Have system under pressure when looking for leaks.

Table 3-79. Centralized Hydraulic System - Hydraulic
Power Unit Troubleshooting (Cont)

| MALFUNCTION | TEST OR INSPECTION | CORRECTIVE ACTION |
|-------------|--------------------------|--|
| | Step 2. | Inspect for leaky tank. Check all bolts, plugs and gaskets. |
| 2. | Loss of fluid from pump. | |
| | Step 1. | Inspect for leaky pipe connections. Check all lines and connections. Be sure no rubbing or excessive vibration is present. Have system under pressure when looking for leaks. |
| | Step 2. | Inspect for leaking gaskets. Check all bolts clamping gasketed covers, while system is under pressure. |
| | Step 3. | Inspect for leaking seals, cracked housing. Refer to paragraph 3-189. |
| 3. | Poor performance. | |
| | Step 1. | Check. for a dirty return oil filter. Remove and replace element. Refer to paragraph 3-187. |
| | Step 2. | Inspect for suction filter indicator showing a dirty filter. Remove and, clean. Refer to paragraph 3-190. |
| | Step 3. | Check for pump rotating slowly, motor running normal. Defective flexible coupling. Refer to paragraph 3-188. |
| 4. | Motor does not run. | |
| | Step 1. | Check for no power to motor. a. Reset circuit breaker. |

Table 3-79. Centralized Hydraulic System - Hydraulic
Power Unit Troubleshooting (Cont).

| MALFUNCTION | TEST OR INSPECTION | CORRECTIVE ACTION |
|-------------|----------------------------|--|
| 4. | Motor does not run (Cont). | |
| | Step 1. | <ul style="list-style-type: none"> b. Press reset button on controller. c. Check fuses in controller. |
| | Step 2. | <ul style="list-style-type: none"> Check that motor does not rotate. a. Motor defective. Replace. Refer to paragraph 3-188. b. Pump defective. Replace. Refer to paragraph 3-189. |
| 5. | Motor runs hot. | |
| | Step 1. | <ul style="list-style-type: none"> Check for overloads. Check for low fluid level in tank. |
| | Step 2. | <ul style="list-style-type: none"> Check for frequent starts and stops. a. Check for intermittent power. b. Too many starts and stops. |
| 6. | Motor runs slow. | |
| | Step 1. | <ul style="list-style-type: none"> Check for defective pump. Replace. Refer to paragraph 3-189. |
| | Step 2. | <ul style="list-style-type: none"> Check for a burnt out motor. Replace. Refer to paragraph 3-188. |
| 7. | Motor runs too fast. | |
| | Step 1. | <ul style="list-style-type: none"> Check for lack of fluid in tank. |
| | Step 2. | <ul style="list-style-type: none"> Pump not pumping as indicated by little or no pressure on gage. Replace pump. Refer to paragraph 3-189. |

Table 3-79. Centralized Hydraulic System - Hydraulic
Power Unit Troubleshooting (Cont).

| MALFUNCTION | TEST OR INSPECTION | CORRECTIVE ACTION |
|---|---|------------------------------------|
| 8. Erratic performance. | Step 1. Check for insufficient fluid in tank as shown on gauge. | Add hydraulic fluid. |
| | Step 2. Check for improper fluid in tank. Drain, flush, change filter, and refill with hydraulic fluid. | |
| 9. Pressure gauge does not indicate pressure. | Step 1. Check for defective gauge. | Replace. Refer to paragraph 3-192. |
| | Step 2. Check for defective isolator. | Replace. Refer to paragraph 3-192. |

Table 3-80. Centralized Hydraulic System Controller
Troubleshooting.

| MALFUNCTION | TEST OR INSPECTION | CORRECTIVE ACTION |
|---------------------------|------------------------------|---------------------|
| 1. Device does not start. | Step 1. Check for overloads. | Press RESET button. |

Table 3-80. Centralized Hydraulic System Controller
 Troubleshooting (Cont).

| MALFUNCTION | TEST OR INSPECTION | CORRECTIVE ACTION |
|-------------|--------------------|-------------------|
|-------------|--------------------|-------------------|

1. Device does not start (Cont).

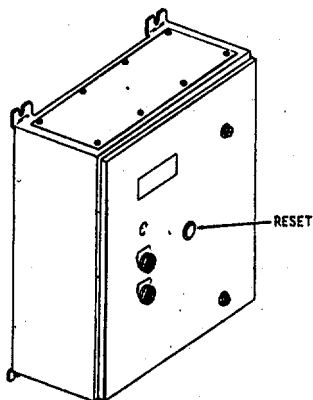

Step 2. Check power to controller.

Check circuit breaker.

Step 3. Check for defective fuse.

Replace. Refer to paragraph 3-191.

Step 4. Check for defective START switch.

Refer to Direct Support Maintenance.

Step 5. Check for defective contactor.

Refer to Direct Support Maintenance.

2. Device does not stop.

Step 1. Check for defective STOP switch.

Refer to Direct Support Maintenance.

3. Controller does not reset.

Step 1. Check for defective RESET switch.

Refer to Direct Support Maintenance.

Table 3-81. Stern Gate Hydraulic System - Troubleshooting.

| MALFUNCTION | TEST OR INSPECTION | CORRECTIVE ACTION |
|-----------------|--------------------|---|
| 1. Inoperative. | Step 1. | Check centralized hydraulic system. Turn system on. Refer to paragraph 2-63. |
| | Step 2. | Inspect that system is turned on and little or no pressure. Refer to table 3-79 for corrective action. |
| | Step 3. | Check directional control valve. Damaged control valve. Refer to paragraph 3-194. |
| | Step 4. | Check hydraulic cylinder. a. Damaged clevis, cotter pin, or swivel. Refer to paragraph 3-196. b. Defective cylinder. Refer to Direct Support Maintenance, paragraph 5-94. |
| | Step 5. | Check for leaking hoses and piping. a. Replace defective hoses. Refer to paragraph 3-195. b. Piping defective. Refer to Direct Support Maintenance, paragraph 5-93. |

Table 3-81. Stern Gate Hydraulic System - Troubleshooting.
(Cont).

| MALFUNCTION | TEST OR INSPECTION | CORRECTIVE ACTION |
|-------------|---------------------|---|
| 2. | Sluggish operation. | |
| | Step 1. | Check centralized hydraulic system. Refer to table 3-79. |
| | Step 2. | Check directional control valve. Damaged control valve. Refer to paragraph 3-194. |
| | Step 3. | Check for misadjusted flow control valves. Readjust. |
| | Step 4. | Check hydraulic cylinders. a. Remove accumulations of salt. b. Replace Refer to paragraph 3-196. |

Table 3-82. Mast Hydraulic System - Troubleshooting.

| MALFUNCTION | TEST OR INSPECTION | CORRECTIVE ACTION |
|-------------|--------------------|---|
| 1. | Inoperative. | |
| | Step 1. | Check centralized hydraulic system. Turn system on. Refer to paragraph 2-63. |

Table 3-82. Mast Hydraulic System - Troubleshooting (Cont).

MALFUNCTION

TEST OR INSPECTION

CORRECTIVE ACTION

1. Inoperative (Cont).

Step 2. Inspect that system is turned on and little or no pressure.

Refer to table 3-79 for corrective action.

Step 3. Check directional control valve and flow control manifold.

a. Damaged control lever.

Refer to paragraph 3-198.

b. Defective valve.

Refer to Direct Support Maintenance.

c. Defective flow control manifold.

Replace, refer to paragraph 3-198.

Repair, refer to Direct Support Maintenance.

Step 4. Check hydraulic ram.

a. Adjusting screw leaking.

Refer to paragraph 3-197.

b. Damaged clevis, cotter pin, or swivel.

Refer to paragraph 3-197.

c. Defective ram.

Refer to Direct Support Maintenance.

Step 5. Inspect for leaking hoses and piping.

a. Replace defective hoses.

Refer to paragraph 3-199.

b. Piping defective.

Refer to Direct Support Maintenance.

Table 3-82. Mast Hydraulic System - Troubleshooting (Cont).

MALFUNCTION
TEST OR INSPECTION**CORRECTIVE ACTION**

2. Sluggish operation.

Step 1. Check centralized hydraulic system.

Refer to table 3-79.

Step 2. Check directional control valve and flow control manifold.

a. Damaged control lever.

Refer to paragraph 3-198.

b. Defective valve.

Refer to Direct Support Maintenance.

c. Defective flow control manifold.

Replace, refer to paragraph 3-198.

Repair, refer to Direct Support Maintenance.

Step 3. Check hydraulic rams.

a. Remove accumulations of salt.

b. Replace. Refer to paragraph 3-197.

Table 3-83. "A" Frame Hydraulic Winch Troubleshooting.

| MALFUNCTION | TEST OR INSPECTION | CORRECTIVE ACTION |
|-------------|--------------------|-------------------|
|-------------|--------------------|-------------------|

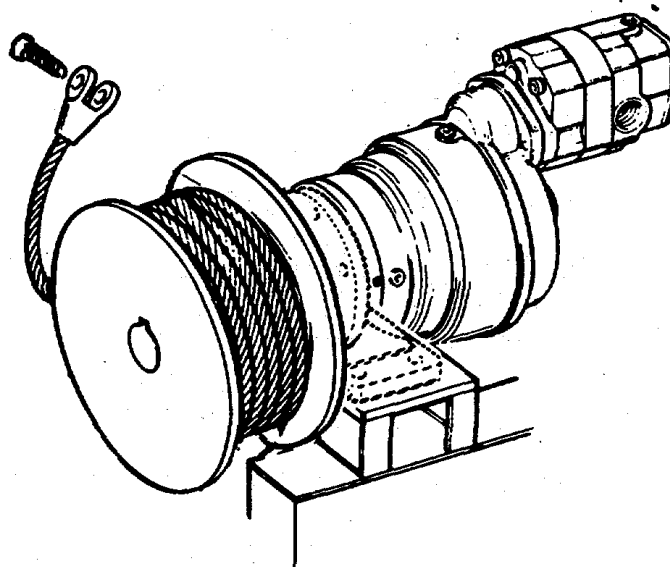

1. Inoperative.
 - Step 1. Check centralized hydraulic system.
Turn system on. Refer to paragraph 2-63.
 - Step 2. Inspect that system is turned on and little or no pressure.
Refer to table 3-79 for corrective action.
 - Step 3. Check directional control valve and flow control manifold.
 - a. Damaged control lever.
Refer to paragraph 3-201.
 - b. Defective valve.
Refer to Direct Support Maintenance.

Table 3-83. "A" Frame Hydraulic Winch Troubleshooting (Cont).

| MALFUNCTION | TEST OR INSPECTION | CORRECTIVE ACTION |
|------------------------|--------------------|--|
| 1. Inoperative (Cont). | Step 4. | Check for defective "A" Frame winch. Refer to paragraph 3-200. |
| | Step 5. | Inspect for leaking hoses and piping leaking. a. Replace defective hoses. Refer to paragraph 3-202. b. Piping defective. Refer to Direct Support Maintenance. |
| | Step 6. | Inspect for broken cable or shackle. Replace. Refer to paragraph 3-200. |
| 2. Sluggish operation. | Step 1. | Check centralized hydraulic system. Refer to table 3-79. |
| | Step 2. | Check directional control valve and flow control manifold. a. Damaged control lever. Refer to paragraph 3-201. b. Defective valve. Refer to Direct Support Maintenance. c. Defective flow control manifold. Replace, refer to paragraph 3-201. Repair, refer to Direct Support Maintenance. |

Table 3-83. "A" Frame Hydraulic Winch Troubleshooting (Cont).

| MALFUNCTION | TEST OR INSPECTION | CORRECTIVE ACTION |
|---------------------------------------|---|--|
| 2. Sluggish operation (Cont). | Step 3. Check "A" Frame winch. | a. Clean and lubricate. b. Replace. Refer to paragraph 3-200. |
| 3. Motor runs but drum does not turn. | Step 1. Inspect for set screws and key missing or broken. | Replace. Refer to paragraph 3-200. |

Table 3-84. Steering Controller - Troubleshooting.

| MALFUNCTION | TEST OR INSPECTION | CORRECTIVE ACTION |
|-------------|--------------------|-------------------|
|-------------|--------------------|-------------------|

1. Hydraulic pump inoperative.
 - Step 1.
 - a. Circuit breaker in power distribution panel.
Reset.
 - b. Reset button on controller.
 - Step 2. Press LOCAL-OFF-REMOTE switch.
Place in LOCAL or REMOTE position.

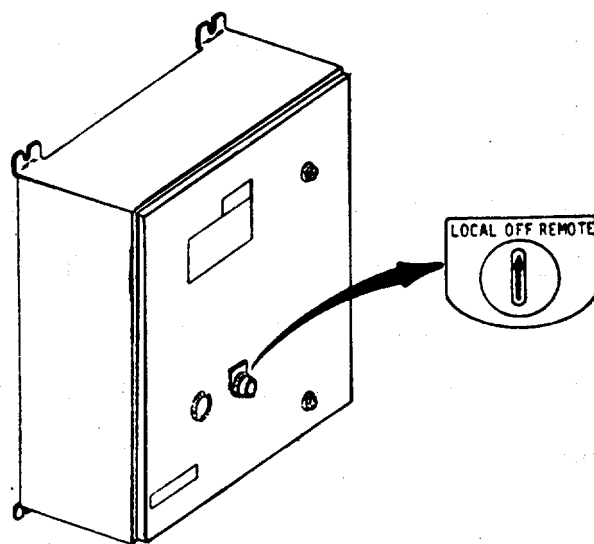

Table 3-84. Steering Controller - Troubleshooting (Cont).

MALFUNCTION

TEST OR INSPECTION

CORRECTIVE ACTION

-
- | MALFUNCTION | TEST OR INSPECTION | CORRECTIVE ACTION | |
|--|--|--|--|
| 1. Hydraulic pump inoperative (Cont). | Step 3. | Check for defective contacts or coil on contactor. Replace. Refer to paragraph 3-205. | |
| | Step 4. | Check thermal overload. Refer to Direct Support Maintenance. | |
| | Step 5. | Defective overload heater, transformer, or switch. Refer to Direct Support Maintenance. | |
| | Step 6. | Inspect for worn, broken, or damaged wiring. Refer to Direct Support Maintenance. | |
| | 2. Hydraulic pump operating - RUN light on steering console in pilothouse not lit. | Step 1. | Check for defective fuses in controller. Replace. Refer to paragraph 3-205. |
| | | Step 2. | Inspect for worn or broken wiring. Refer to Direct Support Maintenance. |
| 3. Hydraulic pump operating - Gyropilot in the pilothouse inoperative. | | Step 1. | Check for defective fuses in controller. Replace. Refer to paragraph 3-205. |
| | Step 2. | Inspect for worn or broken wiring. Refer to Direct Support Maintenance. | |

Table 3-85. Steering Cub Hydraulic Pump - Troubleshooting.

| MALFUNCTION | TEST OR INSPECTION | CORRECTIVE ACTION |
|--------------------------------------|--|--|
| 1. Erratic operation of rudder: | Step 1. Check for defective steering control panel. | Refer to table 3-90. |
| | Step 2. Check for dirt or foreign material in system. | Refer to Direct Support Maintenance. |
| 2. Rudder movement in one direction. | Step 1. Check for defective directional valve. | |
| | Step 2. Inspect for open cabling. | Check and repair. Refer to Direct Support Maintenance. |
| 3. Steering system inoperative. | Step 1. System set for manual operation. | Check steering system to see that all shut-off valves are in position for steering electrically. |
| | Step 2. Check for defective pump unit motor controller. | Refer to table 3-206. |
| | Step 3. Inspect for cylinder by-pass valve that is open. | Close by-pass valve. |
| | Step 4. Check for low oil tank level. | Add hydraulic oil, type 2135th. |
| | Step 5. Check for air leak in pump suction line. | Tighten connections if the problem continues. |
| | | Refer to Direct Support Maintenance. |

Table 3-85. Steering Cub Hydraulic Pump - Troubleshooting.
(Continued).

MALFUNCTION

TEST OR INSPECTION

CORRECTIVE ACTION

Steering System inoperative (Cont).

Step 6. Check for pump shaft that is turning too slowly to prime itself.

Check speed and power to motor.

Step 7. Check for broken pump shaft or rotor.

Refer to Direct Support Maintenance.

Step 8. Check for jammed directional control valve.

Refer to table 3-86.

4. System operates sluggishly.

Step 1. Pump relief valve setting not high enough.

Adjust. Refer to Direct Support Maintenance.

Step 2. Check for pump relief valve sticking open.

Refer to Direct Support Maintenance.

Step 3. Inspect for leak in hydraulic control system cylinders or valves.

Must be tested independently by blocking of circuit progressively.

5. Pump making noise.

Step 1. Check for partially clogged intake line or restricted intake pipe.

Refer to Direct Support Maintenance.

Step 2. Check for small air leak at pump intake piping joints or at pump shaft seal.

Test by pouring oil on joints or around shaft while listening for change in sound of operation; tighten as required. If problem continues, replace the pump.

Refer to paragraph 3-206.

Table 3-85. Steering Cub Hydraulic Pump - Troubleshooting.

(Continued).

| MALFUNCTION | TEST OR INSPECTION | CORRECTIVE ACTION |
|------------------------------|---|--|
| 5. Pump making noise (Cont). | Step 3. Check for coupling misalignment between motor and pump. | Realign or replace as required. Refer to paragraph 3-206. |
| | Step 4. Check for air bubbles in oil. | Check oil level and add hydraulic oil type 2135-th. |
| | Step 5. Check for plugged tank breather. | Clean the breather. |
| 6. Rudder goes hard-over. | Step 1. Check for jammed directional valve. | Refer to Direct Support Maintenance. |
| | Step 2. Check for short in cabling. | Test cables and repair. Refer to Direct Support Maintenance. |

Table 3-86. Steering System - Hydraulic Directional Control Valve Troubleshooting.**NOTE**

Refer to paragraph 3-208 for all maintenance procedures.

MALFUNCTION
TEST OR INSPECTION**CORRECTIVE ACTION**

- | | | |
|----|------------------------------|--|
| 1. | Erratic Pressure. | <p>Step 1. Check for foreign matter in system.</p> <p>Drain, flush and refill system with clean fluid.</p> <p>Step 2. Inspect for worn spool or cover(s).</p> <p>Replace spool or cover(s).</p> <p>Step 3. Check for spool sticking in body or cover.</p> <p>Clean spool. Remove burrs by light lapping.</p> <p>Check freedom of movement on reassembly. Replace if necessary.</p> |
| 2. | Low pressure or no pressure. | <p>Step 1. Check for plugged balance hole in spool.</p> <p>Remove spool and clean out. If necessary, drain system and refill with clean fluid.</p> |
| 3. | Excessive noise or chatter. | <p>Step 1. Check for high oil velocity through valve.</p> <p>Check system.</p> <p>Step 2. Check for distorted spring.</p> <p>Replace spring.</p> <p>Step 3. Check for worn spool or cover(s).</p> <p>Replace spool cover(s).</p> |

Table 3-87. Hydraulic Steering Cylinder and Adjustable Links Troubleshooting.

| MALFUNCTION | TEST OR INSPECTION | CORRECTIVE ACTION |
|--------------------------------------|--|---|
| 1. Cylinder loose. | Step 1. Check for worn or damaged bracket. Replace. Refer to paragraph 3-209. | Step 2. Check for damaged pivot and cotter pin. Replace. Refer to paragraph 3-209. |
| | Step 3. Check for loose tie rods. Tighten. | |
| 2. Cylinder leaking. | Step 1. Inspect hoses. Tighten. | Step 2. Check for defective cylinder. Refer to Direct Support Maintenance. |
| 3. Adjustable links loose. | Step 1. Check for defective slotted hex nuts or cotter pins. Replace. Refer to paragraph 3-209. | Step 2. Check for defective bearings. Replace. Refer to paragraph 3-209. |
| 4. Rudders not at the same position. | Step 1. Check for adjustable link out of adjustment. Readjust and tighten nuts. | |

Table 3-88. Rudder Angle Indicator and Repeatback Transmitter Troubleshooting.

MALFUNCTION
TEST OR INSPECTION**CORRECTIVE ACTION**

1. Inoperative. No incoming power.
 - Step 1. Switch on Intercommunication Panel 2L-107.
Place switch in ON position.
 - Step 2. Check for defective fuse.
Replace 3 amp fuse. Refer to paragraph 3-211.
 - Step 3. Check for loose wiring connections.
Tighten.

2. Indicator dimmer lights inoperative.
 - Step 1. Check for defective lamp(s).
Replace. Refer to paragraph 3-211.
 - Step 2. Check for defective dimmer control.
Replace. Refer to paragraph 3-211.

3. Angle shown on indicator and actual rudder angle differ.
 - Step 1. Check for binding transmitter arm.
Lubricate.
 - Step 2. Check for defective arm, spring pin or tie rod.
Replace. Refer to paragraph 3-211.
 - Step 3. Check wiring and connections.
Replace worn or broken wires, or terminal strip.
Refer to paragraph 3-211.
 - Step 4. Check for loose servo motor.
Tighten. Refer to paragraph 3-211.
 - Step 5. Check that problem is still not solved.
Refer to Direct Support Maintenance.

Table 3-89. Heading Selector Troubleshooting.

| MALFUNCTION | TEST OR INSPECTION | CORRECTIVE ACTION |
|-------------------------------------|---|---|
| 1. Dimmer lights inoperative. | Step 1. Check for defective lamps. | Replace. Refer to paragraph 3-215. |
| | Step 2. Check for defective variable resistor, switch or transformer. | Refer to Direct Support Maintenance. |
| 2. Selector inoperative or erratic. | Step 1. Check for worn, or broken wires. | Replace or repair. Refer to Direct Support Maintenance. |
| | Step 2. Check for defective auto pilot. | Refer to Direct Support Maintenance. |
| | Step 3. Inspect steering control panel. | Refer to table 3-90. |

Table 3-90. Steering Control Panel Troubleshooting.

| MALFUNCTION | TEST OR INSPECTION | CORRECTIVE ACTION |
|-------------|--------------------|-------------------|
|-------------|--------------------|-------------------|

1. Inoperative - POWER AVAIL lamps not lit.
 - Step 1. Controller in steering compartment turned off.
Place LOCAL-OFF-REMOTE switch in either LOCAL or REMOTE position.
 - Step 2. Check for defective controller in steering compartment.
Refer to table 3-84.
 - Step 3. Inspect for lit fuse indicator.
Replace. Refer to paragraph 3-214.

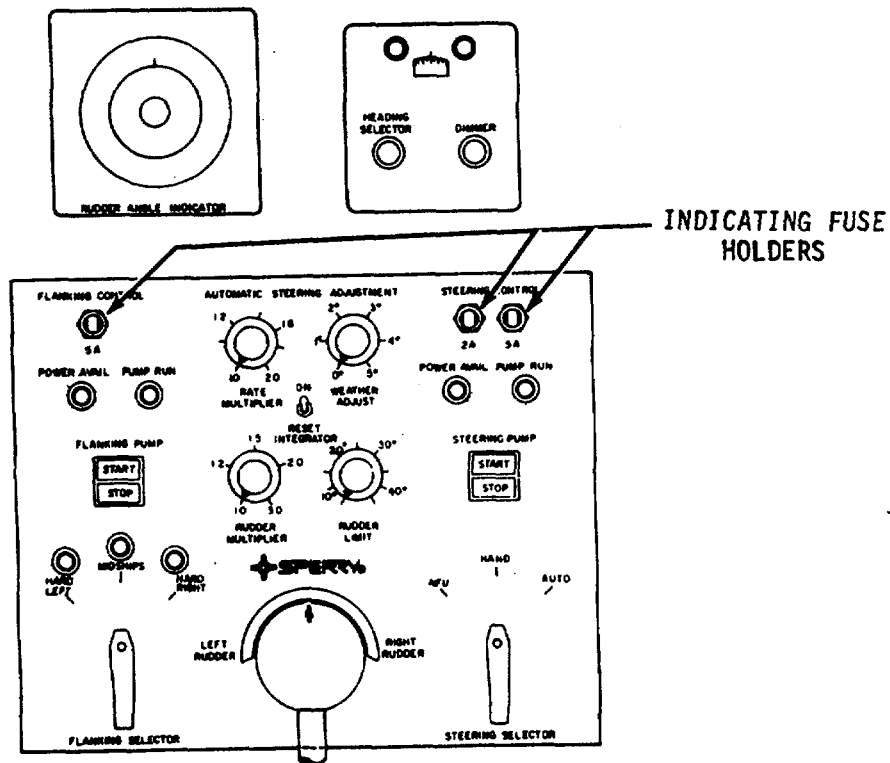

Table 3-90. Steering Control Panel Troubleshooting (Cont).

| MALFUNCTION | TEST OR INSPECTION | CORRECTIVE ACTION |
|--|---|---|
| 1. Inoperative - POWER AVAIL lamps not lit (Cont). | Step 4. Check for burnt out POWER AVAIL lamp. | Replace. Refer to paragraph 3-214. |
| 2. Unable to turn on steering pumps. | Step 1. Check for controller in steering compartment not in REMOTE. | Place LOCAL-OFF-REMOTE switch in REMOTE position. |
| | Step 2. Check for defective lamp or fuse. | See MALFUNCTION 1. |
| | Step 3. Check for defective pump START switch. | Replace. Refer to paragraph 3-214. |
| 3. Steering lever moves but rudder does not. | Step 1. Check for defective steering handle or hub. | Replace. Refer to paragraph 3-214. |
| | Step 2. Inspect for loose or broken wiring. | Tighten or replace wiring. Refer to paragraph 3-214. If problem continues, refer to Direct Support Maintenance. |
| 4. Steering action erratic. | Step 1. Inspect for loose or broken wiring loose. | Tighten or replace wiring. Refer to paragraph 3-214. If problem continues, refer to Direct Support Maintenance. |

Table 3-90. Steering Control Panel Troubleshooting (Cont).

MALFUNCTION**TEST OR INSPECTION****CORRECTIVE ACTION**

5. Automatic steering controls inoperative or erratic.
- Step 1. Check for defective switch.
Replace. Refer to paragraph 3-214.
- Step 2. Check for defective variable resistors.
Replace. Refer to paragraph 3-214.

Table 3-91. Remote Magnetic Heading System Troubleshooting.

MALFUNCTION**TEST OR INSPECTION****CORRECTIVE ACTION**

1. Inoperative (D.C. Distribution Box CP24-1)
- Step 1. Inspect for switch turned off.
Turn switch on.
- Step 2. Check for blown fuse(s).
Replace fuse(s).
- Step 3. Check for defective wiring.
Refer to Direct Support Maintenance.
- Step 4. Check for defective indicator or transmitter.
Refer to Direct Support Maintenance.
2. Incorrect heading.
- Step 1. Check calibration adjustment.
Refer to Direct Support Maintenance.
- Step 2. Check for defective indicator, wiring or transmitter.
Refer to General Support Maintenance.

Table 3-91. Remote Magnetic Heading System Troubleshooting (Cont).

| MALFUNCTION | TEST OR INSPECTION | CORRECTIVE ACTION |
|-------------|---------------------------|---|
| 3. | Dial lights inoperative. | |
| | Step 1. | Check for defective lamp. Replace. Refer to paragraph 3-216. |
| 4. | Heading selector binding. | |
| | Step 1. | Check for defective control shaft or dial. Refer to paragraph 3-216. |
| | Step 2. | If problem continues. Refer to Direct Support Maintenance. |

Table 3-92. Ship's Course Indicator Troubleshooting.

| MALFUNCTION | TEST OR INSPECTION | CORRECTIVE ACTION |
|-------------|--------------------|-------------------|
|-------------|--------------------|-------------------|

1. Indicator inoperative (dial does not respond, dial lamps out).
 - Step 1. No power.
 - Check 115V reference voltage supply, check fuses between indicator and gyro compass. If fuse is blown, disconnect and check ship's wiring to terminals LC and LCC.
 - Correct fault and replace fuse.

2. Dial response is meaningless, lamps are lit.
 - Step 1. Improper power phase.
 - Check wiring to terminal LC and LCC. Correct as necessary. Check that power is actually present.

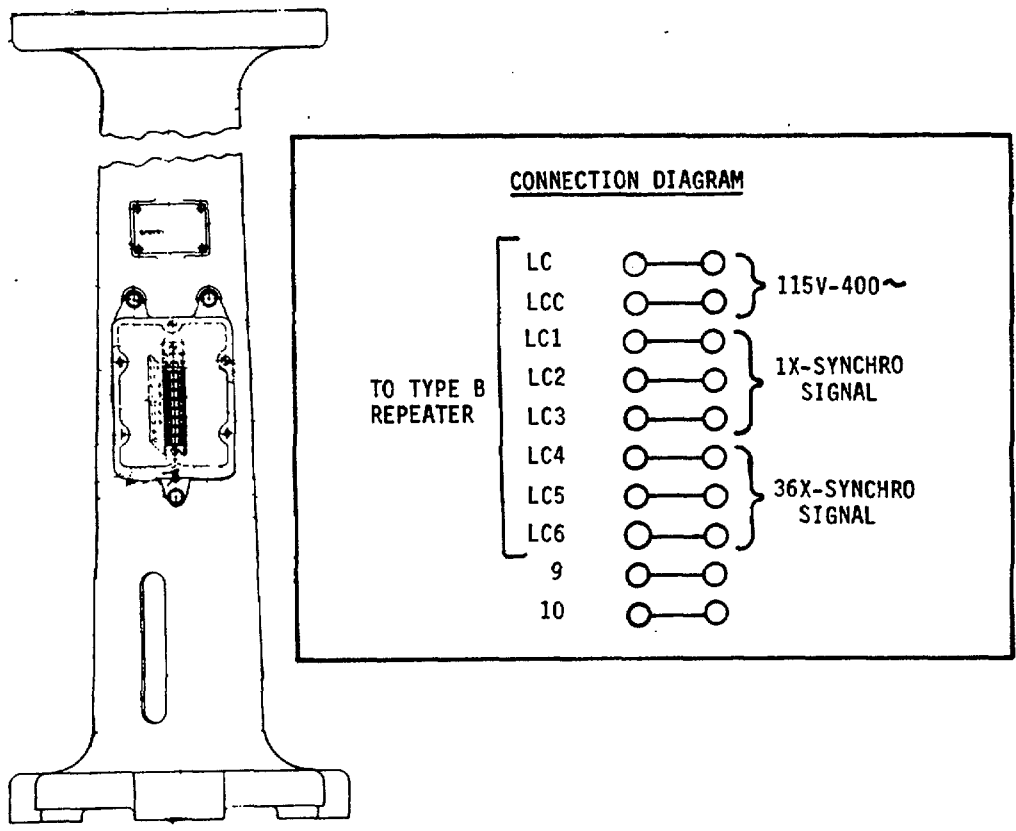

Table 3-92. Ship's Course Indicator Troubleshooting (Cont).

| MALFUNCTION | TEST OR INSPECTION | CORRECTIVE ACTION |
|--|---|--|
| 3. No response. | Step 1. Inspect for fouled gear train. | Refer to Direct Support Maintenance. |
| | Step 2. Check for burned out rotary components. | Refer to Direct Support Maintenance. |
| | Step 3. Check for no power to servomotor. | Refer to Direct Support Maintenance. |
| 4. Dial of two-speed unit rotates continuously in an increasing direction. | Step 1. No signal from control transformers to amplifier; anti-stickoff voltage drives servo. | Refer to Direct Support Maintenance. |
| 5. Dial travels slowly in one direction only. | Step 1. Amplifier is unbalanced or open circuited. | Refer to General Support Maintenance. |
| 6. Dial moves sluggishly. | Step 1. Check for dirt in gear train. | Refer to Direct Support Maintenance. |
| | Step 2. Damping is excessive. | Adjust damping rheostat. Refer to paragraph 3-218. |
| | Step 3. Amplifier unbalanced or lacking in gain. | Refer to Direct Support Maintenance. |

Table 3-92. Ship's Course Indicator Troubleshooting (Cont).

MALFUNCTION

TEST OR INSPECTION

CORRECTIVE ACTION

-
- | MALFUNCTION | TEST OR INSPECTION | CORRECTIVE ACTION |
|-------------|---|---|
| <hr/> | | |
| 7. | Dial of two-speed indicator moves alternately fast and slow, may lock occasionally. | |
| | Step 1. | No signal from IX control transformer. Refer to Direct Support Maintenance. |
| | Step 2. | IX and 36X synchros not set at proper electrical position. Refer to Direct Support Maintenance. |
| 8. | Indicator does not move freely in gimbals. | |
| | Step 1. | Deposits of salt or other corrosive material. Clean. |
| | Step 2. | Check for proper adjustment. Refer to paragraph 3-218. |
| 9. | Indicator glass dial. | |
| | Step 1. | Inspect for fogged glass. Refer to Direct Support Maintenance. |
| | Step 2. | Check for cracked or broken glass. Refer to Direct Support Maintenance. |
| 10. | Incorrect course. | |
| | Step 1. | Gyro Compass problems. Refer to Direct Support Maintenance. |
| | Step 2. | Incorrect alignment of pedestal and bracket. Perform installation procedures in paragraph 2-168. |

INDEX

PARAGRAPH
OR TABLE

A

| | |
|---|-------|
| "A" Frame Hydraulic Winch..... | T3-83 |
| Anchor Winch | |
| Disconnect Clutch..... | T3-50 |
| Hydraulic Pump..... | T3-58 |
| Hydraulic Tank | |
| Balanced Piston Relief Valves..... | T3-52 |
| Check Valves..... | T3-53 |
| Directional Control Valve..... | T3-56 |
| Hydraulic Tank..... | T3-57 |
| Pressure Control Valves..... | T3-54 |
| Pressure Reducing Valves..... | T3-55 |
| Slack Puller..... | T3-49 |
| Torque Converter..... | T3-51 |
| Winch..... | T3-48 |
| Anchor Winch Engine | |
| Abnormal Engine Coolant Operating Temperature..... | T3-66 |
| Abnormal Engine Operation..... | T3-61 |
| Excessive Crankcase Pressure..... | T3-64 |
| Exhaust Smoke Analysis..... | T3-59 |
| Hard Starting..... | T3-60 |
| Hydrostarter | |
| Cranking Speed Too Low..... | T3-69 |
| Fluid Emerges Around Rubber Boot of Hand Pump..... | T3-77 |
| Fluid Emerges from the Reservoir Filler Cap When Starter Is Used..... | T3-76 |
| Hand Pump Fails to Discharge Fluid..... | T3-72 |
| High Pressure in System (3500 Psi (24,133 kPa) or above)..... | T3-75 |
| Loss of Accumulator Precharge (Nitrogen)..... | T3-75 |
| Loss of Fluid Pressure When Engine Is Not Running..... | T3-71 |
| Loss of Fluid From Reservoir..... | T3-70 |
| Starter Turns but Engine Does Not..... | T3-73 |
| Low or High Exhaust Valve Opening Pressure..... | T3-67 |
| Low or No Accumulator Pressure..... | T3-68 |
| Low Oil Pressure..... | T3-65 |
| No Fuel or Insufficient Fuel..... | T3-62 |

INDEX (Cont)

PARAGRAPH
OR TABLE

B

| | |
|-----------------------|-------|
| Bow Ramp Winch | |
| Brake | T3-46 |
| Bow Winch | |
| Bow Winch Motor | T3-47 |
| Bow Winch | T3-45 |

C

| | |
|------------------------------|-------|
| Centralized Hydraulic System | |
| Controller..... | T3-80 |
| Hydraulic Power Unit | T3-79 |

G

| | |
|--|-------|
| Generator | T3-42 |
| Generator Engine | |
| Abnormal Engine Coolant Operating Temperature..... | T3-29 |
| Abnormal Engine Operation..... | T3-24 |
| Excessive Crankcase Pressure..... | T3-27 |
| Exhaust Smoke Analysis | T3-22 |
| Hard Starting | T3-23 |
| High Lubricating Oil Consumption..... | T3-26 |

H

| | |
|---|-------|
| Hydrostarter | |
| Cranking Speed Too Low | T3-32 |
| Fluid Emerges Around Rubber Boot of Hand Pump..... | T3-40 |
| Fluid Emerges from Ends of Starter Control Valve When Starter Is Operated | T3-41 |
| Fluid Emerges from Reservoir Filler Cap When Starter Is Used | T3-39 |
| Hand Pump Fails to Discharge Fluid..... | T3-35 |
| High Pressure in System (3500 psi (24,133 kPa or above) | T3-38 |
| Loss of Accumulator Precharge (Nitrogen) | T3-37 |
| Loss of Fluid Pressure When Engine Is Not Running..... | T3-34 |
| Loss of Fluid from Reservoir | T3-33 |
| Loss or No Accumulator Pressure | T3-31 |
| Starter Turns but Engine Does Not..... | T3-36 |
| Low or High Exhaust Valve Opening Pressure..... | T3-30 |

INDEX (Cont)

PARAGRAPH
OR TABLE

H (Continued)

| | |
|---|-------|
| Low Oil Pressure | T3-28 |
| No Fuel or Insufficient Fuel..... | T3-25 |
| Heading Selector | T3-89 |
| Hydraulic Steering cylinder & Adjustable Links..... | T3-87 |

M

| | |
|-----------------------------|-------|
| Marine Gear..... | |
| Mast Hydraulic System | T3-82 |

Propulsion Engine

Propulsion Engine

| | |
|---|-------|
| Abnormal Engine Coolant Operating Temperature | T3-8 |
| Abnormal Engine Operation..... | T3-3 |
| Excessive Crankcase Pressure..... | T3-6 |
| Exhaust Smoke Analysis | T3-1 |
| Hard Starting | |
| High Lubricating Oil Consumption..... | T3-5 |
| Cranking Speed Too Low | T3-12 |
| Fluid Emerges Around Rubber Boot of Hand Pump..... | T3-20 |
| Fluid Emerges from Ends of Starter Control Valve When Starter is Operated | T3-21 |
| Fluid Emerges from the Reservoir Filler Cap When Starter Is Used | T3-19 |
| Hand Pump Fails to Discharge Fluid | T3-15 |
| High Pressure in System (3500 psi (24,133 kPa) or above)..... | T3-18 |
| Loss of Accumulator Precharge (Nitrogen) | T3-17 |
| Loss of Fluid Pressure - Engine Not Running | T3-14 |
| Loss of Fluid from Reservoir | T3-13 |
| Loss or No Accumulator Pressure | T3-11 |
| Starter Turns but Engine Does Not..... | T3-16 |
| Low or High Exhaust Valve Opening Pressure | T3-9 |
| Low Oil Pressure | T3-7 |
| No Fuel or Insufficient Fuel | T3-4 |

INDEX (Cont)

PARAGRAPH
OR TABLE

R

| | |
|---|-------|
| Rectifier - 24 VDC | |
| Remote Magnetic Heading System | T3-91 |
| Rudder Angle Indicator & Repeatback Transmitter | T3-88 |

S

| | |
|---|-------|
| Ship's Course Indicator | |
| Steering Controller | |
| Steering Control Panel | |
| Steering Cub Hydraulic Pump | T3-85 |
| Steering System | |
| Hydraulic Directional Control Valve | T3-86 |
| Stern Gate Hydraulic System | T3-81 |
| Switchboard | |

By Order of the Secretary of the Army:

Official:

JOHN A. WICKHAM, JR.
General, United States Army
Chief of Staff

ROBERT M. JOYCE
Major General, United States Army
The Adjutant General

DISTRIBUTION:

To be distributed in accordance with DA Form 12-25D, Operator Maintenance requirements for Marine Equipment, All.

RECOMMENDED CHANGES TO EQUIPMENT TECHNICAL PUBLICATIONS

| | | | |
|--|------------|--|-------------------|
|  <p style="font-size: small; margin: 0;"><i>THEN...JOT DOWN THE DOPE ABOUT IT ON THIS FORM. CAREFULLY TEAR IT OUT, FOLD IT AND DROP IT IN THE MAIL.</i></p> | | SOMETHING WRONG WITH PUBLICATION | |
| | | FROM: (PRINT YOUR UNIT'S COMPLETE ADDRESS) | |
| | | DATE SENT | |
| PUBLICATION NUMBER | | PUBLICATION DATE | PUBLICATION TITLE |
| IN THIS SPACE, TELL WHAT IS WRONG AND WHAT SHOULD BE DONE ABOUT IT. | | | |
| BE EXACT PIN-POINT WHERE IT IS | | | |
| PAGE NO. | PARA-GRAPH | FIGURE NO. | TABLE NO. |
| | | | |
| PRINTED NAME, GRADE OR TITLE AND TELEPHONE NUMBER | | SIGN HERE | |

The Metric System and Equivalents

Linear Measure

1 centimeter = 10 millimeters = .39 inch
 1 decimeter = 10 centimeters = 3.94 inches
 1 meter = 10 decimeters = 39.37 inches
 1 dekameter = 10 meters = 32.8 feet
 1 hectometer = 10 dekameters = 328.08 feet
 1 kilometer = 10 hectometers = 3,280.8 feet

Weights

1 centigram = 10 milligrams = .15 grain
 1 decigram = 10 centigrams = 1.54 grains
 1 gram = 10 decigram = .035 ounce
 1 decagram = 10 grams = .35 ounce
 1 hectogram = 10 decagrams = 3.52 ounces
 1 kilogram = 10 hectograms = 2.2 pounds
 1 quintal = 100 kilograms = 220.46 pounds
 1 metric ton = 10 quintals = 1.1 short tons

Liquid Measure

1 centiliter = 10 milliliters = .34 fl. ounce
 1 deciliter = 10 centiliters = 3.38 fl. ounces
 1 liter = 10 deciliters = 33.81 fl. ounces
 1 dekaliter = 10 liters = 2.64 gallons
 1 hectoliter = 10 dekaliters = 26.42 gallons
 1 kiloliter = 10 hectoliters = 264.18 gallons

Square Measure

1 sq. centimeter = 100 sq. millimeters = .155 sq. inch
 1 sq. decimeter = 100 sq. centimeters = 15.5 sq. inches
 1 sq. meter (centare) = 100 sq. decimeters = 10.76 sq. feet
 1 sq. dekameter (are) = 100 sq. meters = 1,076.4 sq. feet
 1 sq. hectometer (hectare) = 100 sq. dekameters = 2.47 acres
 1 sq. kilometer = 100 sq. hectometers = .386 sq. mile

Cubic Measure

1 cu. centimeter = 1000 cu. millimeters = .06 cu. inch
 1 cu. decimeter = 1000 cu. centimeters = 61.02 cu. inches
 1 cu. meter = 1000 cu. decimeters = 35.31 cu. feet

Approximate Conversion Factors

| To change | To | Multiply by | To change | To | Multiply by |
|---------------|--------------------|-------------|--------------------|---------------|-------------|
| inches | centimeters | 2.540 | ounce-inches | Newton-meters | .007062 |
| feet | meters | .305 | centimeters | inches | .394 |
| yards | meters | .914 | meters | feet | 3.280 |
| miles | kilometers | 1.609 | meters | yards | 1.094 |
| square inches | square centimeters | 6.451 | kilometers | miles | .621 |
| square feet | square meters | .093 | square centimeters | square inches | .155 |
| square yards | square meters | .836 | square meters | square feet | 10.764 |
| square miles | square kilometers | 2.590 | square meters | square yards | 1.196 |
| acres | square hectometers | .405 | square kilometers | square miles | .386 |
| cubic feet | cubic meters | .028 | square hectometers | acres | 2.471 |
| cubic yards | cubic meters | .765 | cubic meters | cubic feet | 35.315 |
| fluid ounces | milliliters | 29.573 | cubic meters | cubic yards | 1.308 |
| pints | liters | .473 | milliliters | fluid ounces | .034 |
| quarts | liters | .946 | liters | pints | 2.113 |
| gallons | liters | 3.785 | liters | quarts | 1.057 |
| ounces | grams | 28.349 | liters | gallons | .264 |
| pounds | kilograms | .454 | grams | ounces | .035 |
| short tons | metric tons | .907 | kilograms | pounds | 2.205 |
| pound-feet | Newton-meters | 1.356 | metric tons | short tons | 1.102 |
| pound-inches | Newton-meters | .11296 | | | |

Temperature (Exact)

| | | | | |
|----|------------------------|----------------------------|---------------------|----|
| °F | Fahrenheit temperature | 5/9 (after subtracting 32) | Celsius temperature | °C |
|----|------------------------|----------------------------|---------------------|----|

